



Assembly Instructions

Folding door AL603EEF

Version 09/2023

Translation of the original **Assembly Instructions**

SCHNEIDER Torsysteme Gesellschaft m.b.H.

Table of contents

Contents

1	Essential information	5
1.1	<i>Explanation of symbols used in safety information</i>	5
1.2	<i>General safety information</i>	5
2	Scope of supply of the door system	6
2.1	<i>Parts of the door system</i>	6
2.2	<i>Required tools</i>	6
2.3	<i>Assembly material (not part of the scope of supply)</i>	6
3	General information	7
3.1	<i>Setup/operation site requirements</i>	7
3.2	<i>Information on installing the door</i>	7
3.3	<i>Information on using the door</i>	7
4	Installation	8
4.1	<i>Preparation</i>	8
4.1.1	90° guide rail in front of/behind the soffit	8
4.1.2	90° guide rail in the soffit	10
4.1.3	180° guide rail in front of/behind the soffit	12
4.1.4	180° guide rail in the soffit	14
4.2	<i>Frame installation</i>	16
4.2.1	Installation through 90° guide rail in front of/behind the soffit	16
4.2.2	Bracket installation 90° guide rail in front of/behind the soffit	18
4.2.3	90° guide rail in the soffit	20
4.2.4	180° guide rail in front of/behind the soffit	22
4.2.5	180° guide rail corner soffit	24
4.3	<i>Ground guide rails</i>	26
4.3.1	BF-light NIRO ground guide	26
4.3.2	DA threshold	28
4.3.3	20D threshold	29
4.4	<i>Door leaf installation</i>	31
4.4.1	Even number of leaves	31
4.4.2	Uneven number of leaves	34
4.4.3	Door hinge installation for individual leaves	38
4.4.4	Active leaf/walk-through door pusher/door knob	40
4.5	<i>Frame fine adjustment</i>	41
4.6	<i>Sheet metal cover installation</i>	42
4.6.1	90° guide rail in front of/behind the soffit	42
4.6.2	90° guide rail in the soffit	44
4.6.3	180° guide rail in front of/behind the soffit	47

4.6.4	180° guide rail corner soffit	48
4.7	<i>Drive system installation</i>	49
4.7.1	BASIC drive on the first leaf (opening inwards)	49
4.7.2	BASIC drive on the second leaf (opening inwards)	53
4.7.3	BASIC drive on the first leaf (opening outwards)	54
4.7.4	BASIC drive on the second leaf (opening outwards)	56
4.7.5	BASIC drive, internal (opening outwards)	58
4.7.6	POWER drive	61
4.7.7	POWER drive, internal (opening outwards)	66
4.8	<i>Additional hinge for RC2/WK2 version</i>	69
4.9	<i>Additional hinge for installation of emergency release</i>	71
5	Disassembly and disposal	72
5.1	<i>Disassembly</i>	72
5.2	<i>Disposal</i>	72

Dear customer!

Thank you for your confidence in our Schneider door systems.

We would like to point out that the installation of the door system may only be carried out by a specialised company in order to guarantee the proper function and longevity of the product. This way, defects caused by assembly errors, which may occur later during the service life of the door system, can be avoided.

To ensure the safe and trouble-free use of the door system, please read the operating and maintenance instructions as well as the cleaning instructions.

The detailed representation of your individual door can be found in your release drawing.

Your Schneider Team

1 Essential information

1.1 Explanation of symbols used in safety information



Information on safe use



Tips for use and practical information

1.2 General safety information

- Close off the danger area extensively before installation
- Persons who are not responsible for installing the door must not enter the danger area
- A secure footing is required for installation
- Installation must be carried out by a specialist company
- To avoid crushing injuries, the door may only be closed and opened when there are no persons in the area of the door
- The door must be taken out of use in case of defects and a competent fitter must be called in for inspection
- During installation, all general safety and accident prevention regulations must be observed
- The expert fitters must be trained in the use of safety equipment and in the handling of hand and power tools

2 Scope of supply of the door system

2.1 Parts of the door system

- Running rail
- Frame parts
- Door leaf
- Assembly package with hardware and small parts
- Special accessories

The scope of supply depends on the respective type of door system (see order confirmation).

2.2 Required tools

- Impact drill
- Metal and concrete drill bits size 8, 10 and 12 mm
- Spanners and sockets size 13, 17, 19, 2x24 and 2x30 mm
- Set of Allen keys
- Measuring tools: Spirit level, measuring tape, laser
- Ladder or work platform
- Wooden poles for support
- Wedges for securing
- Screw clamps

2.3 Assembly material (not part of the scope of supply)

The fastening material is to be selected on the basis of the type of ground the door will be installed on.

Common suitable fastening options:

- Concrete:
 - Brass expansion dowels
 - M10 x 60 mm hex bolts
 - Washer
 - HSA M10 x 90mm anchors
- Hollow brick:
 - Frame dowels, e.g.: HILTI HRD-UGS 12x80/10U



To ensure the right type of fastening material, we recommend consulting a specialist.

3 General information

3.1 Setup/operation site requirements

- The ground must be level and plane
- On the opening side of the doors, the walls must be flush
- Only install the door in walls that structurally allow for its installation
- Adequate water drainage should be provided outside
- No electrical or installation lines must be running through the wall in the area of installation

3.2 Information on installing the door

- Once installed, the door must meet the requirements of EN 12604
- Depending on the version, the door is installed in front of or behind the soffit
- Leave elements in their packaging until you need them for assembly

3.3 Information on using the door

- The door may only be used if the requirements of EN 12453 are met
- Don't place objects in the area of the door
- Don't leave the door half way open

4 Installation

4.1 Preparation

4.1.1 90° guide rail in front of/behind the soffit

1

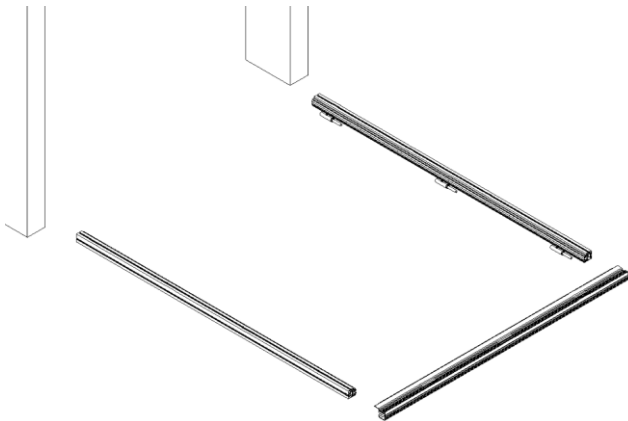

- Position frame parts and guide rail in front of the opening

2

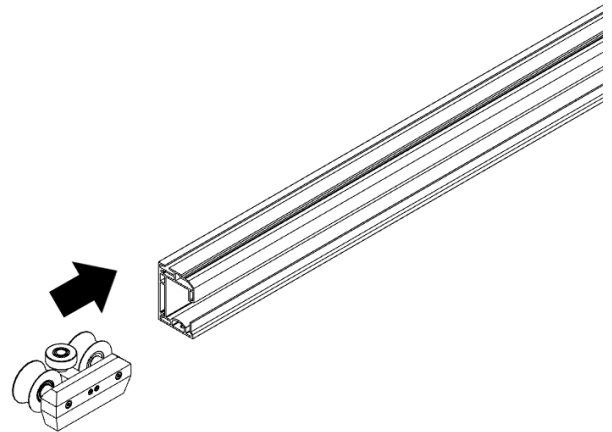

- Correctly insert the running gear into the guide rail (secure against falling out)
- Note: for the version with a 4-leaf set, insert the small running gear first

3

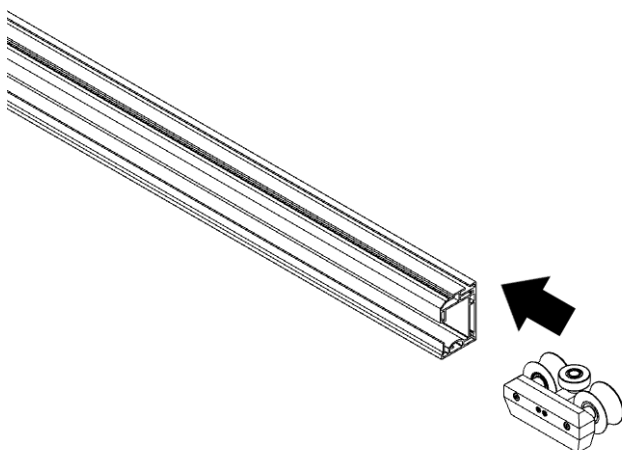

4

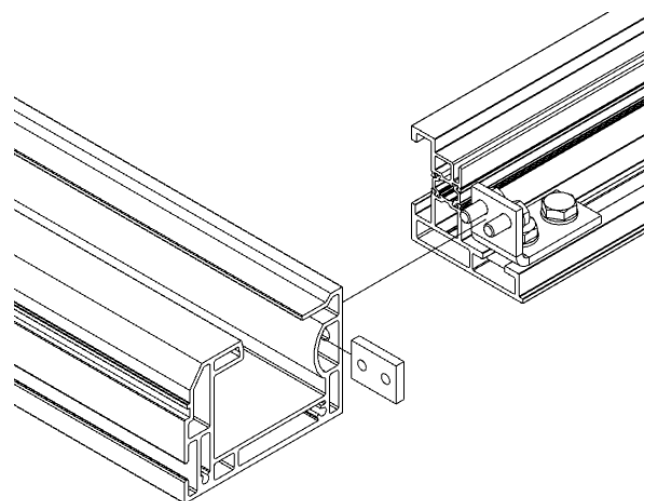
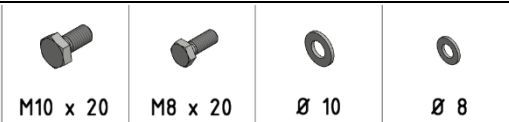

- Bolt on frame parts

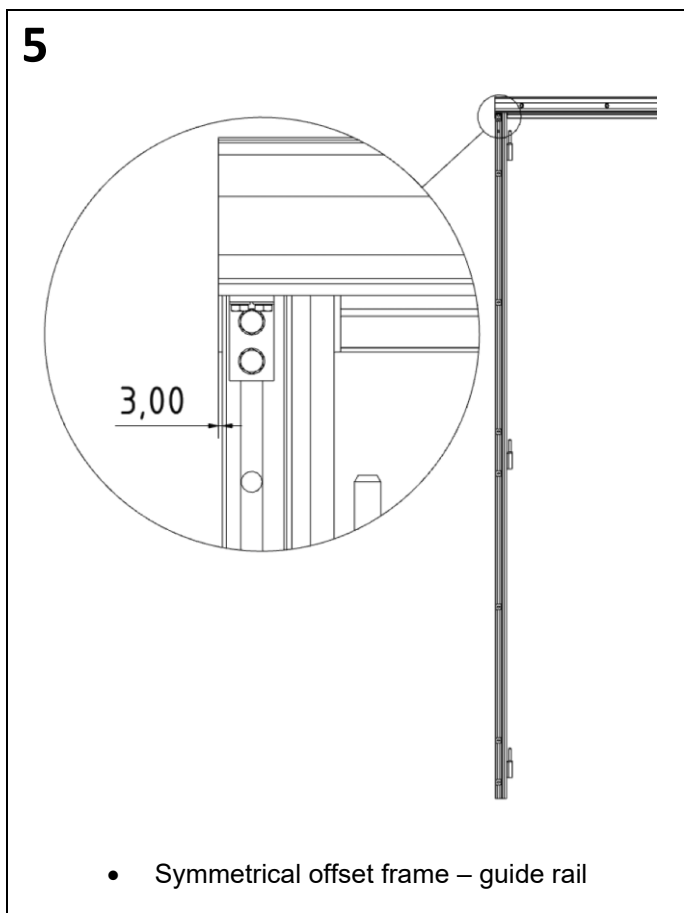

4.1.2 90° guide rail in the soffit

1

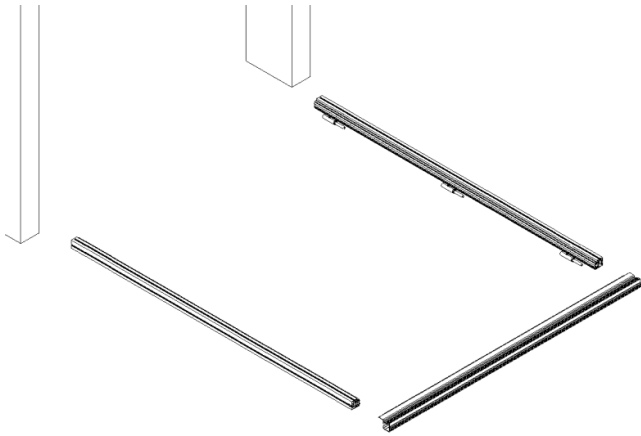

- Position frame parts and guide rail in front of the opening

2

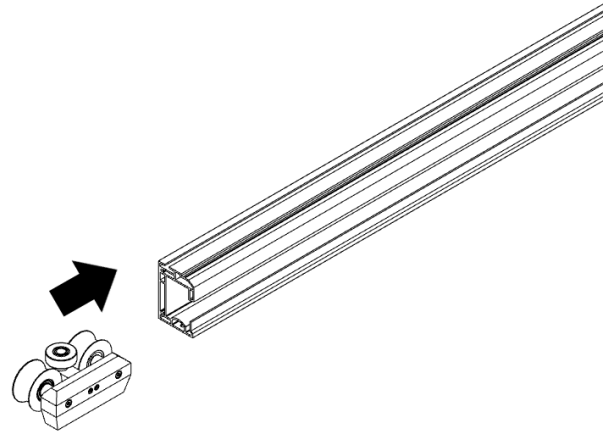

- Correctly insert the running gear into the guide rail (secure against falling out)
- Note: for the version with a 4-leaf set, insert the small running gear first

3

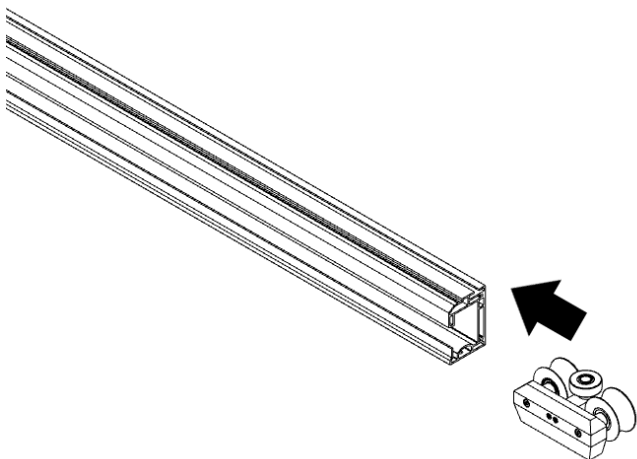

4

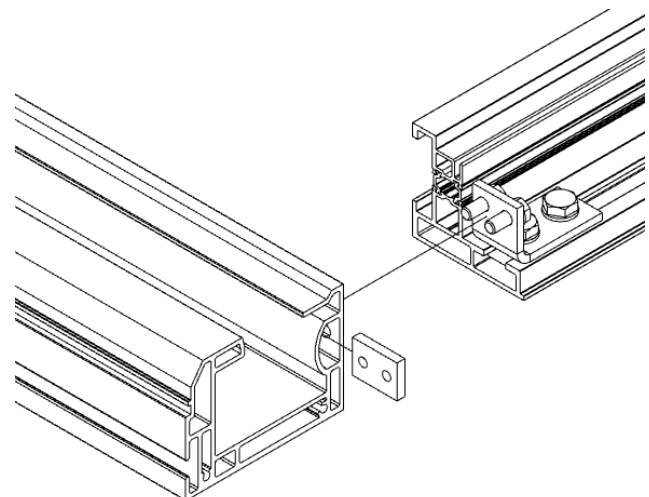
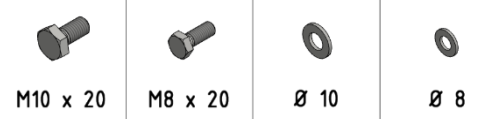

- Bolt on frame parts

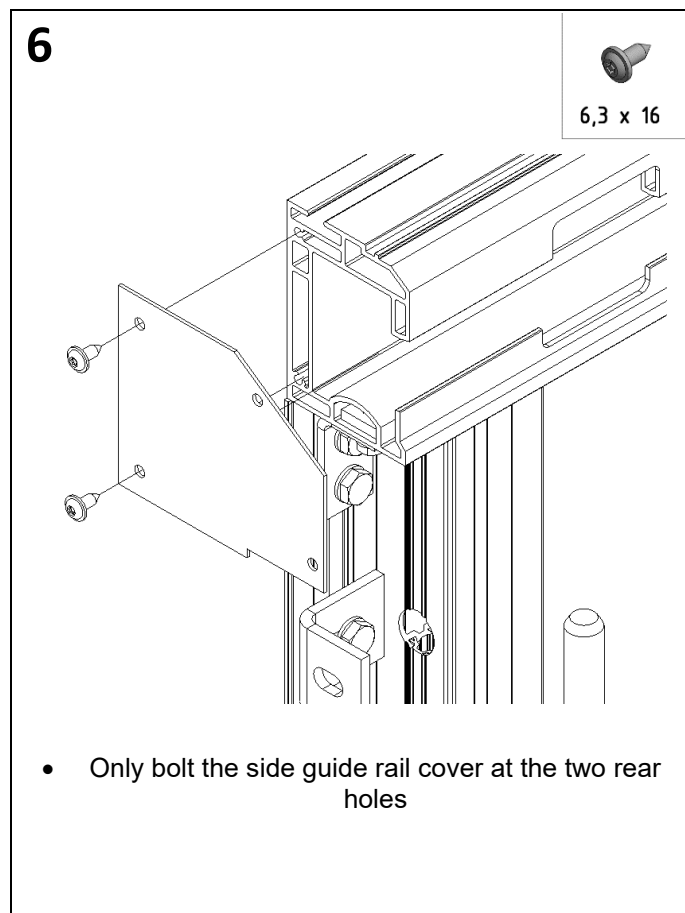
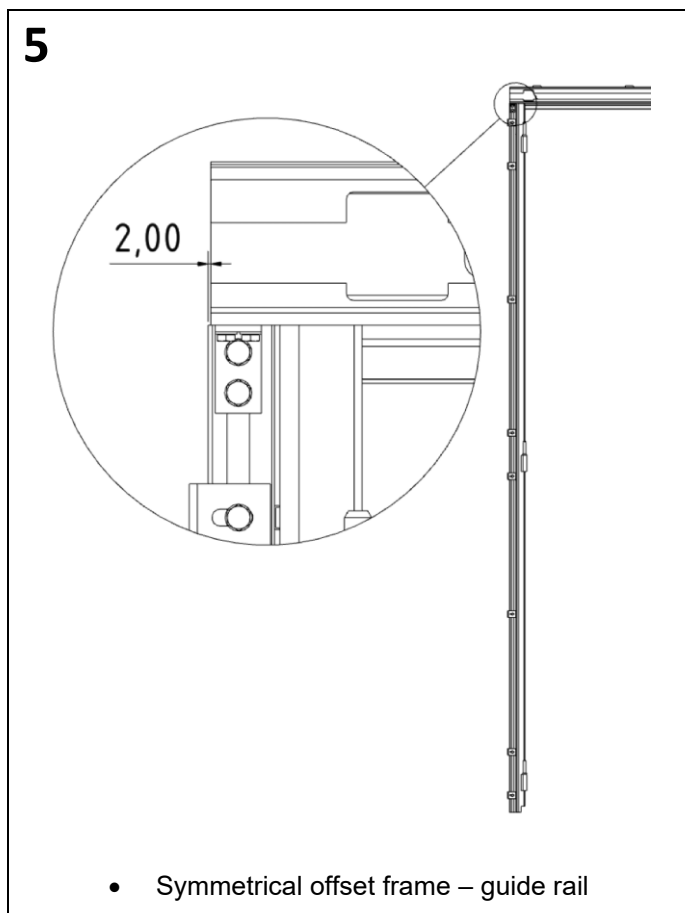

4.1.3 180° guide rail in front of/behind the soffit

1

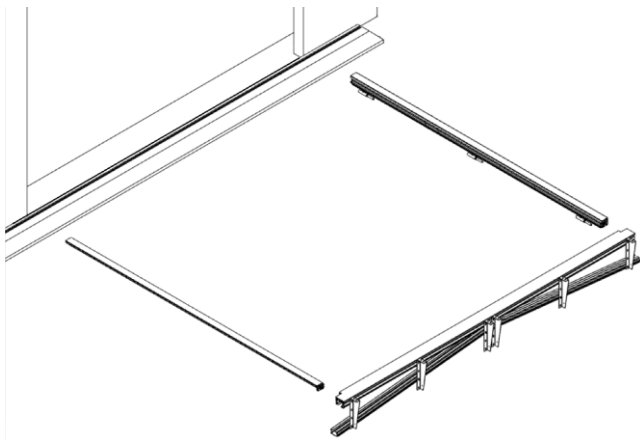

- Position frame parts and guide rail in front of the opening

2

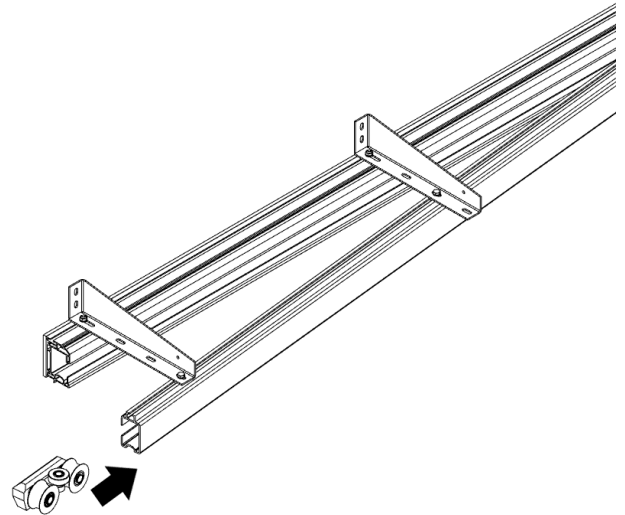

- Correctly insert the running gear into the guide rail (secure against falling out)

3

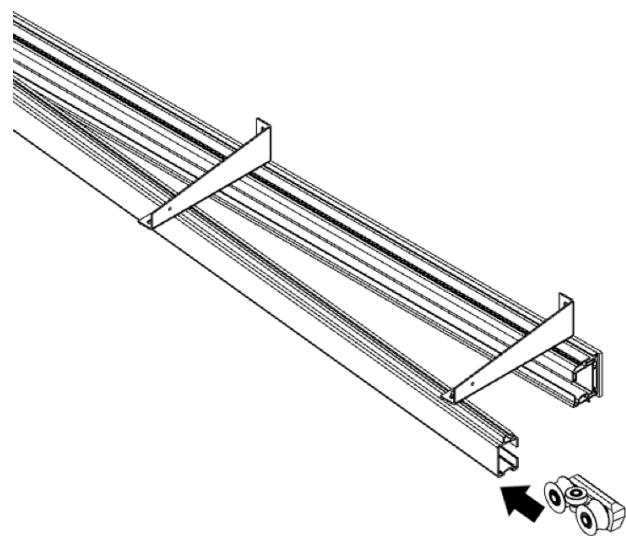

4

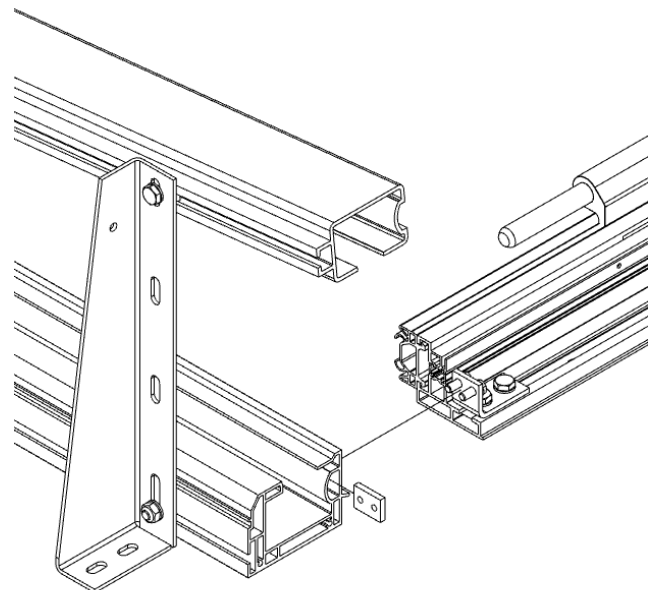
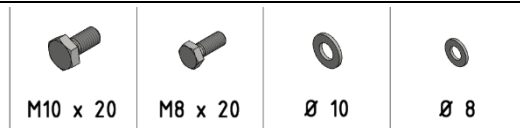

- Bolt on frame parts

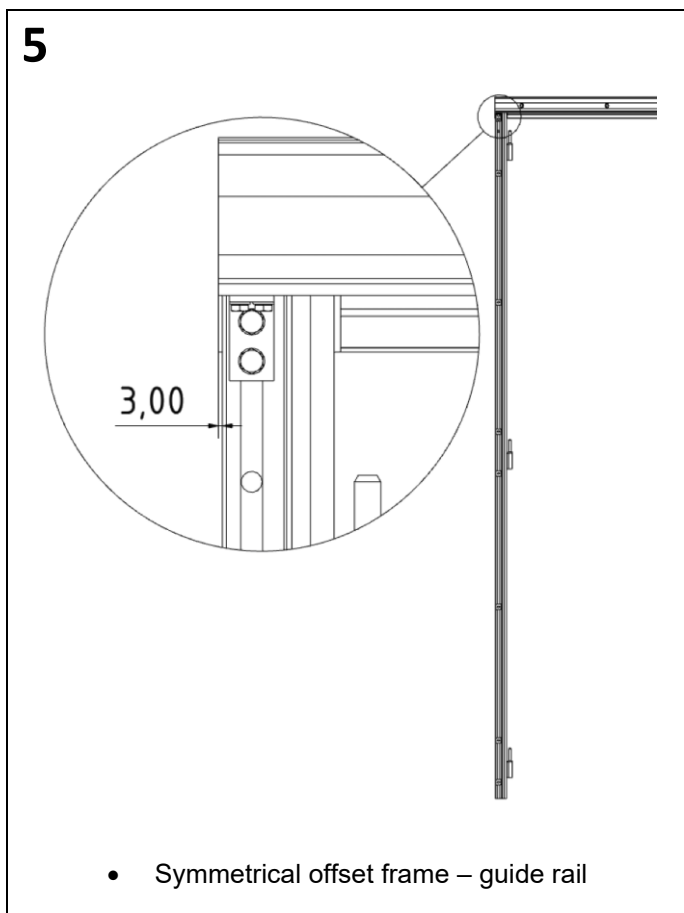

4.1.4 180° guide rail in the soffit

1

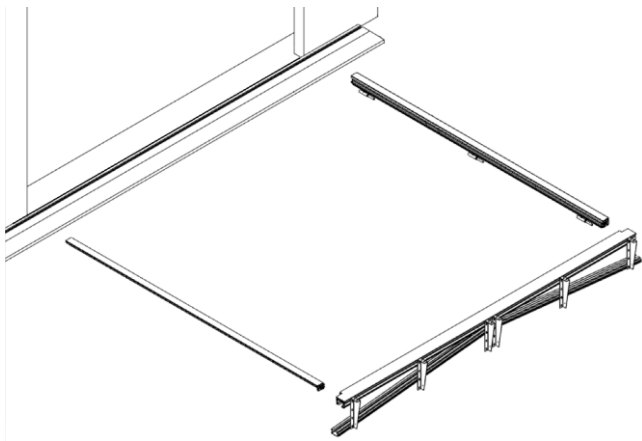

- Position frame parts and guide rail in front of the opening

2

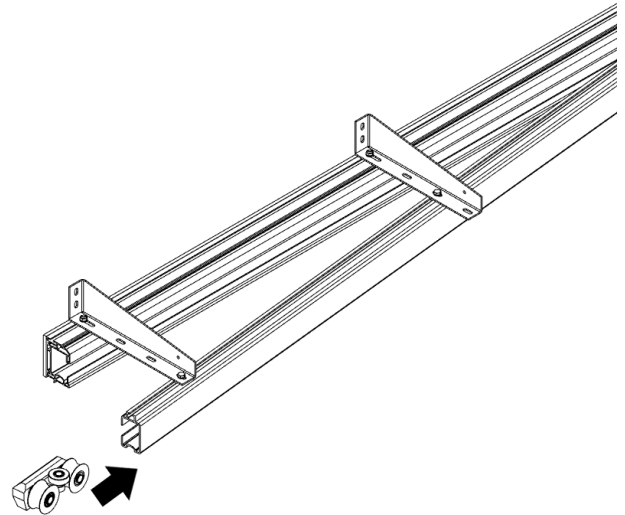

- Correctly insert the running gear into the guide rail (secure against falling out)

3

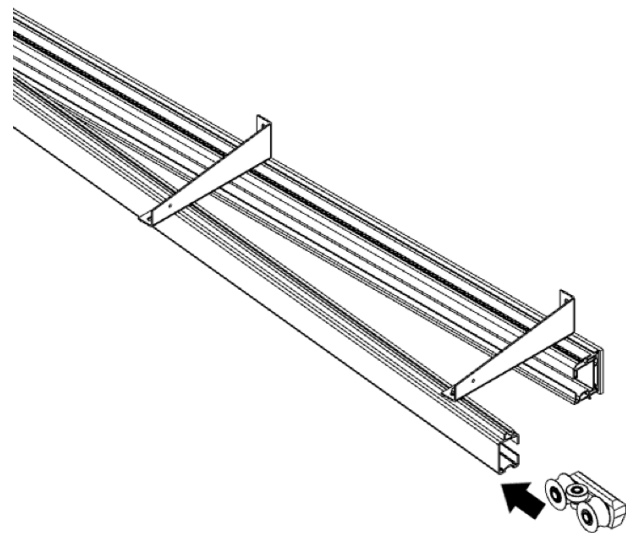

4

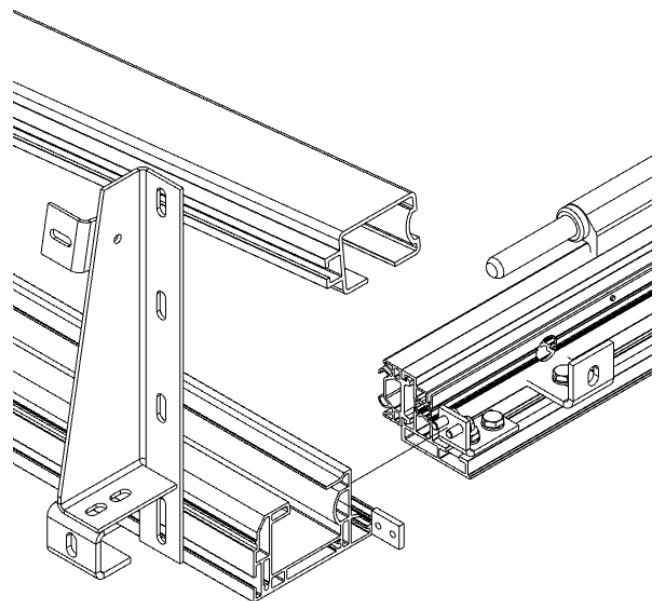
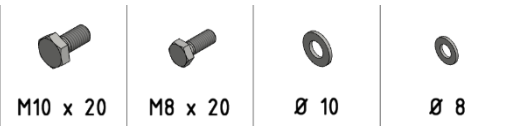

- Bolt on frame parts

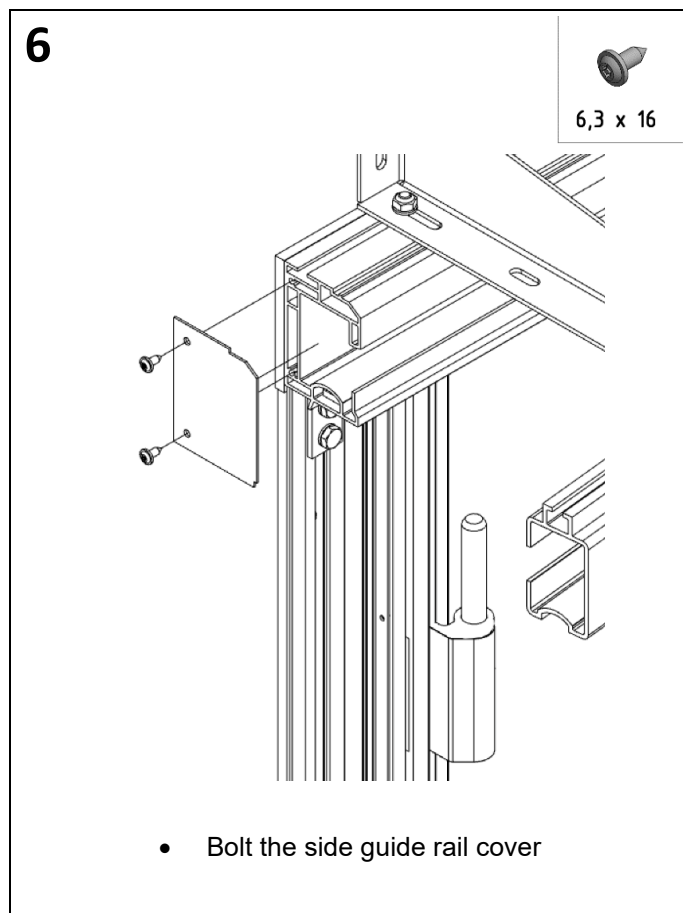
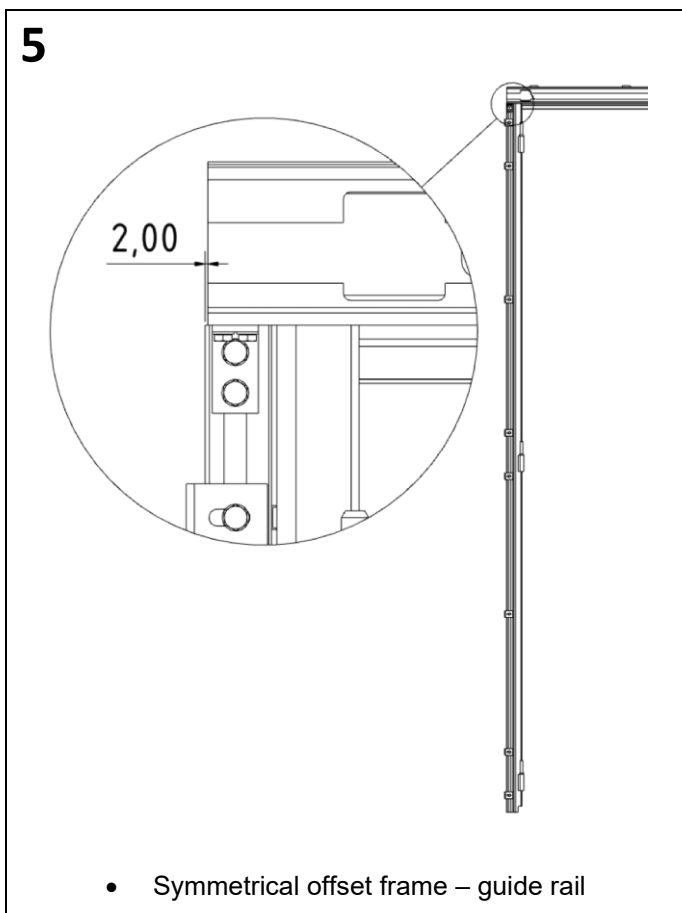

4.2 Frame installation

4.2.1 Installation through 90° guide rail in front of/behind the soffit

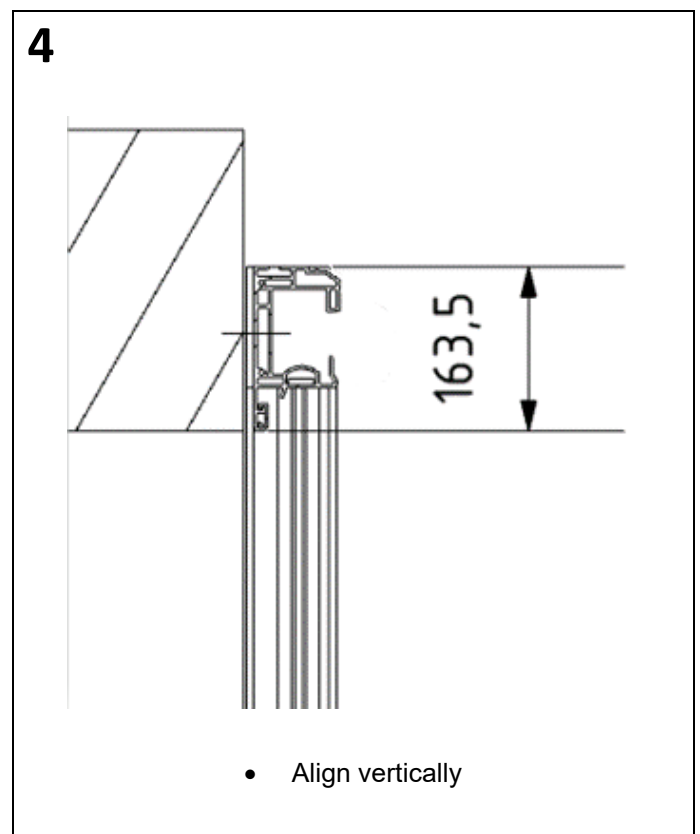
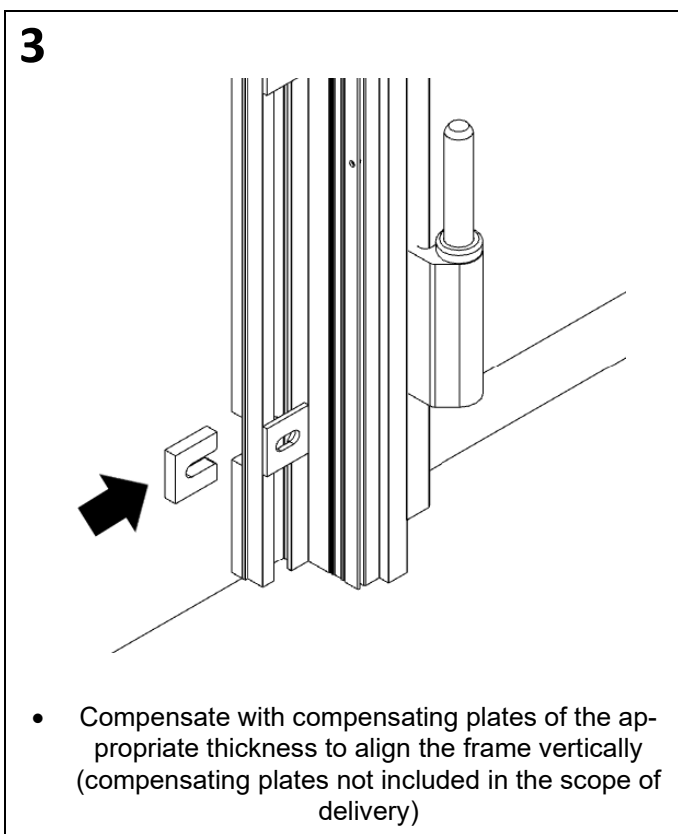
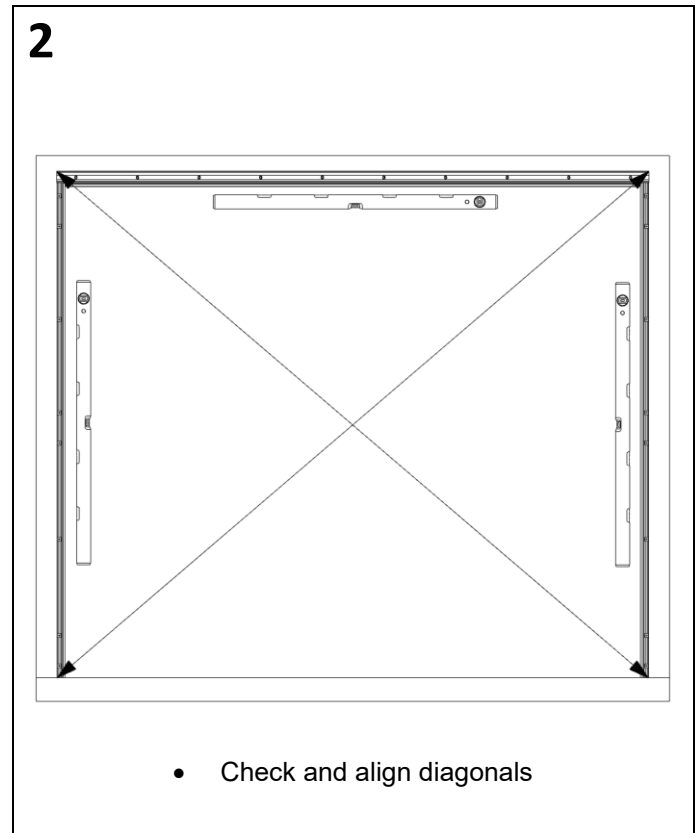
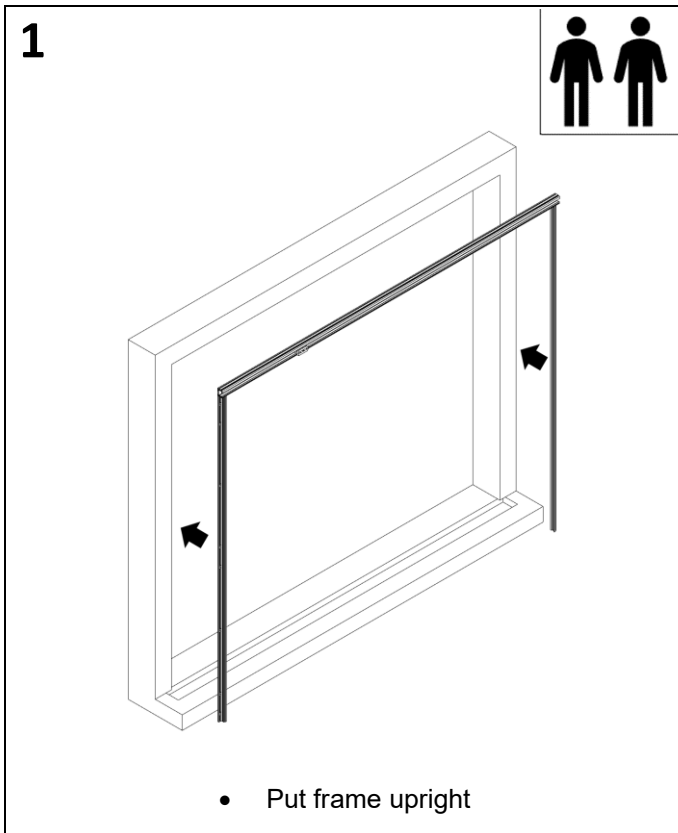

5

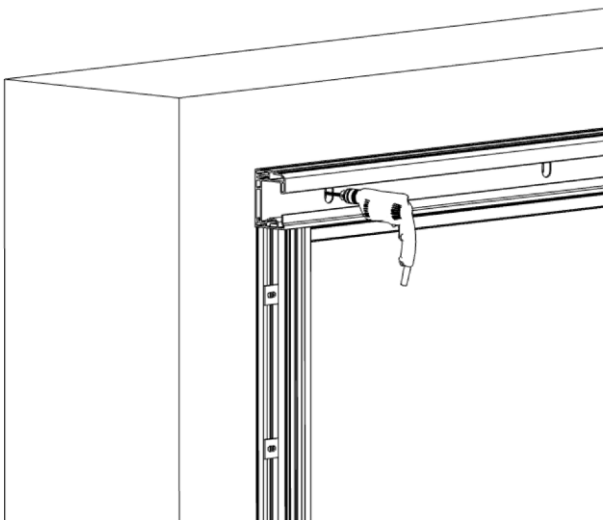

- Drill and bolt guide rail

6

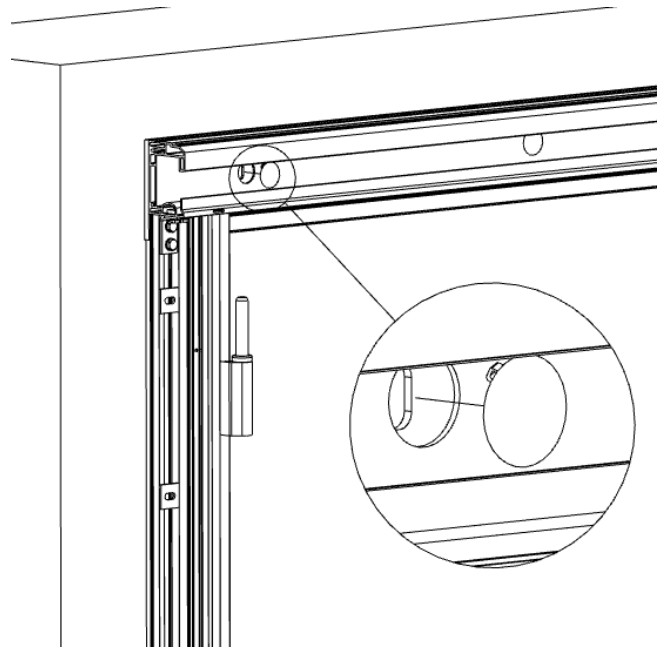

- Install the cover cap in each installation hole of the guide rail after bolting

7

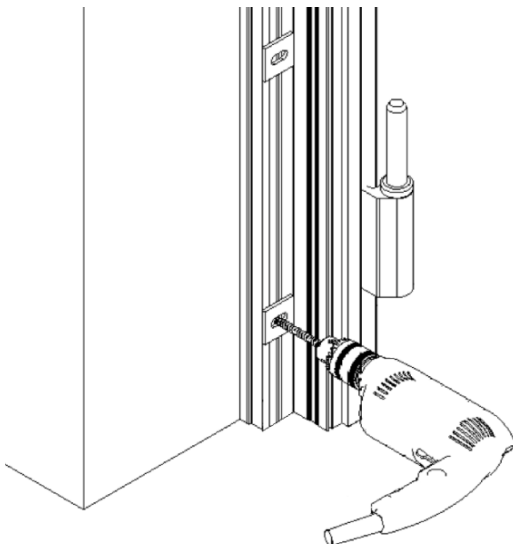

- Only drill through the lowest installation hole on the left and right and bolt the frame (fastening torque 30Nm)
- Wait with drilling and bolting the others until all leaves are installed

4.2.2 Bracket installation 90° guide rail in front of/behind the soffit

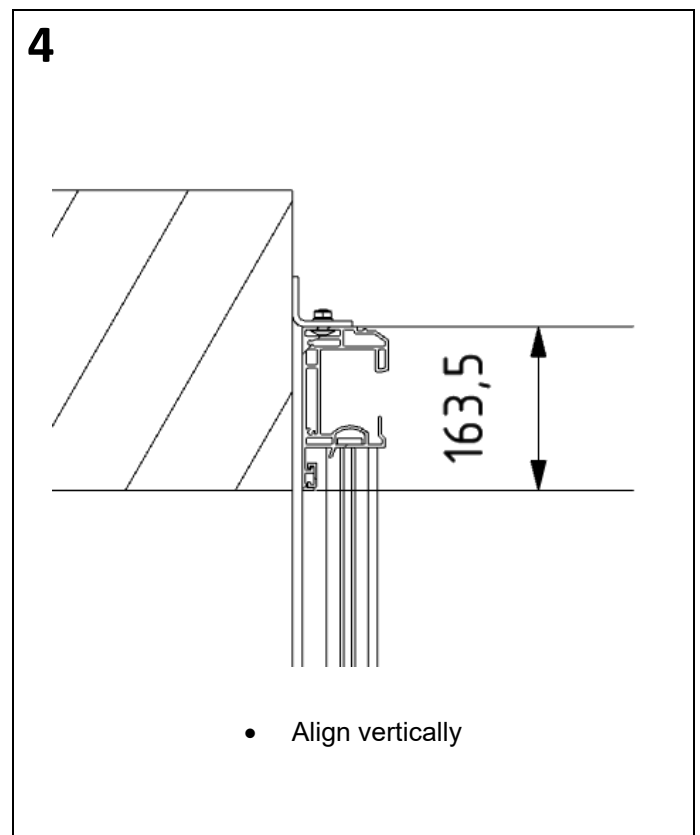
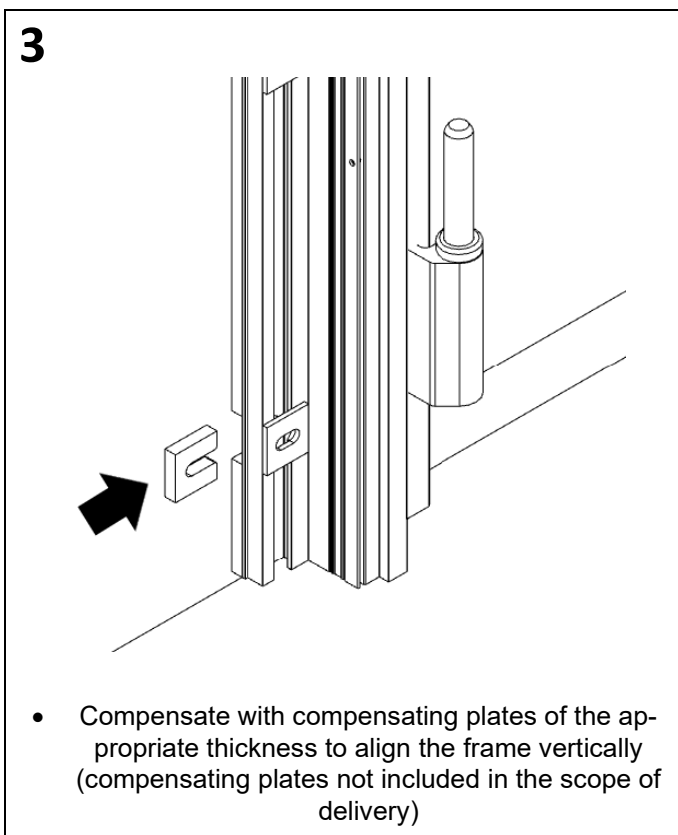
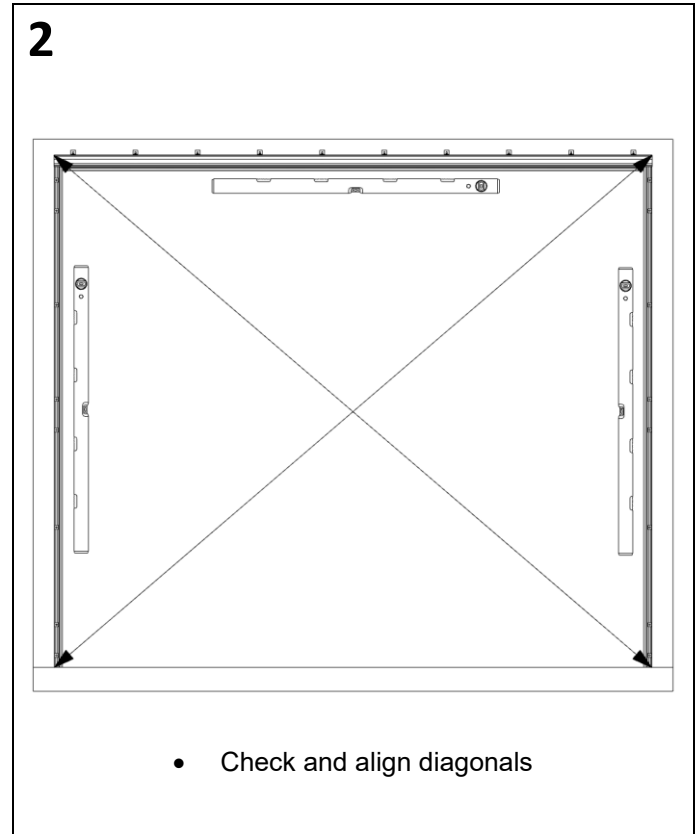
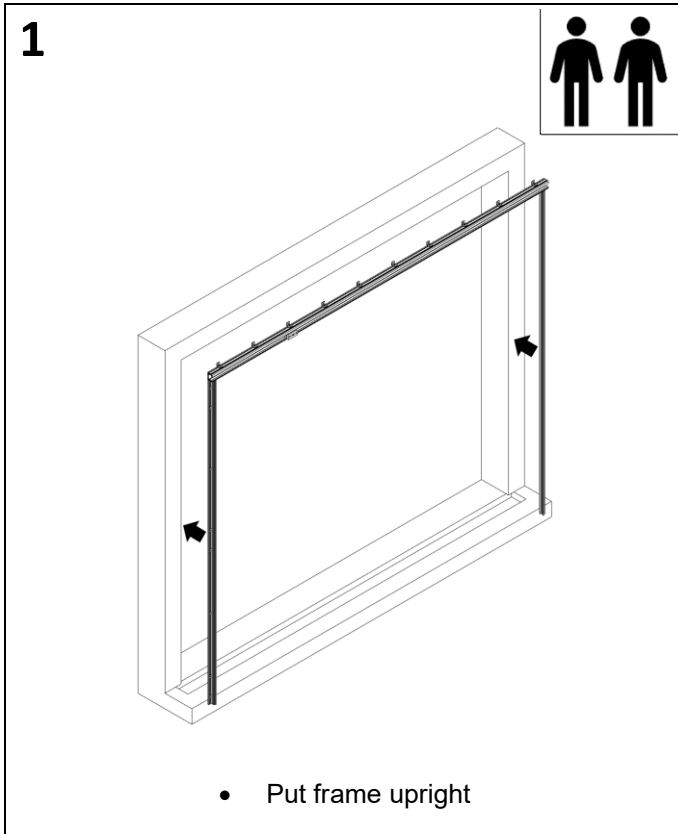

5

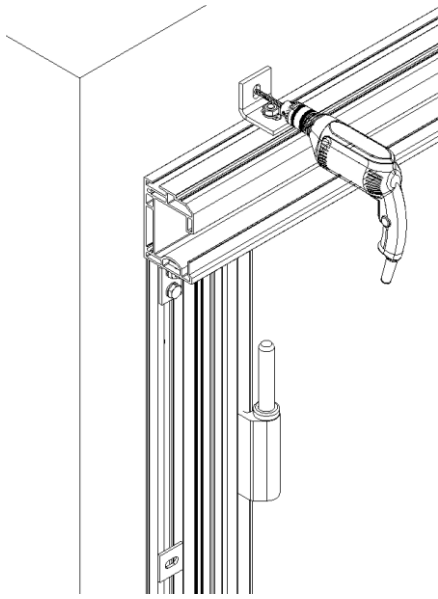

- Drill and bolt guide rail

6

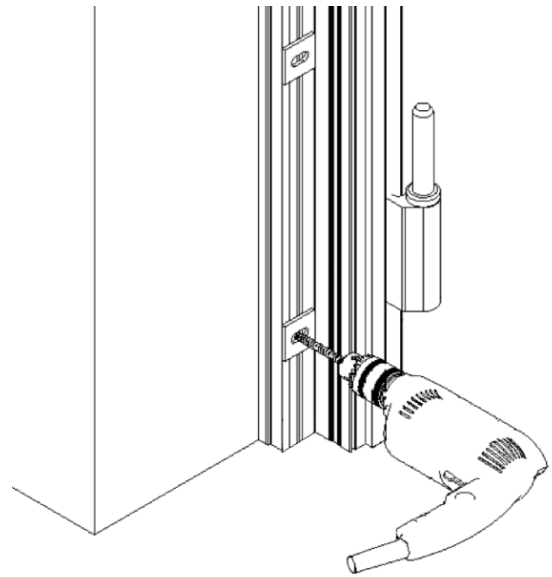

- Only drill through the lowest installation hole on the left and right and bolt the frame (fastening torque 30Nm)
- Wait with drilling and bolting the others until all leaves are installed

4.2.3 90° guide rail in the soffit

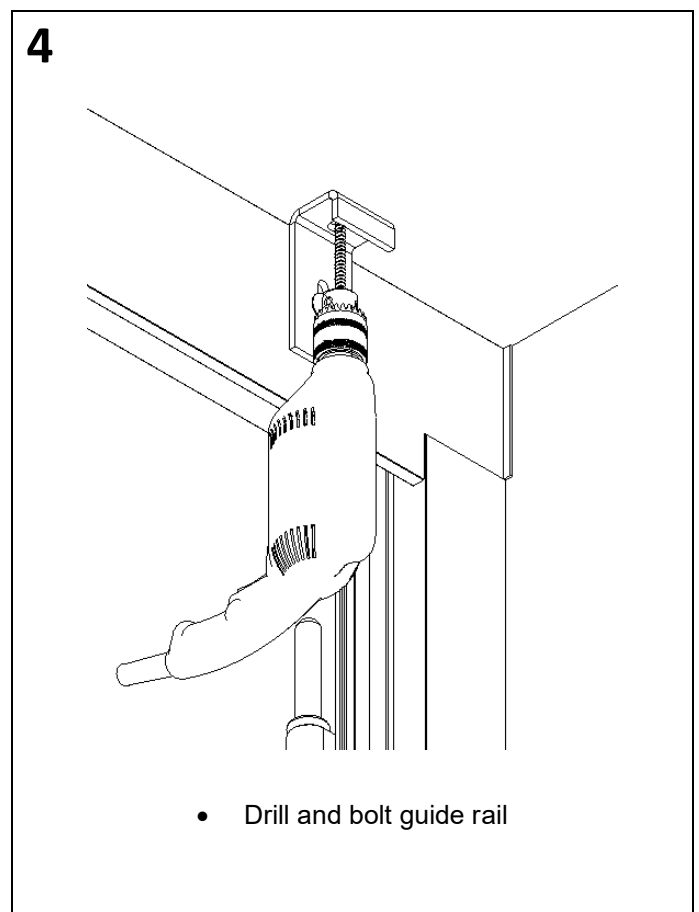
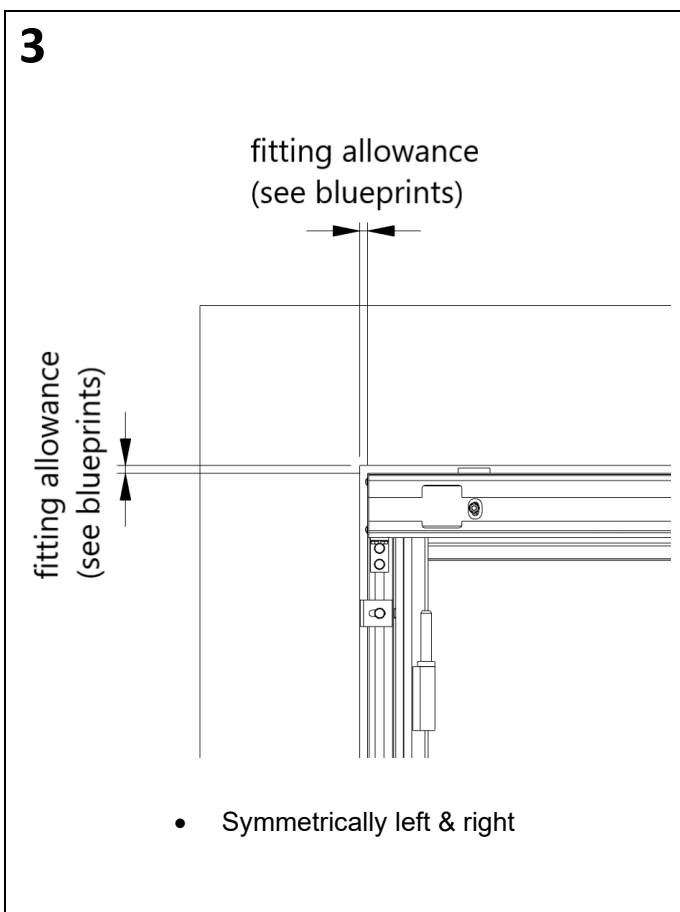
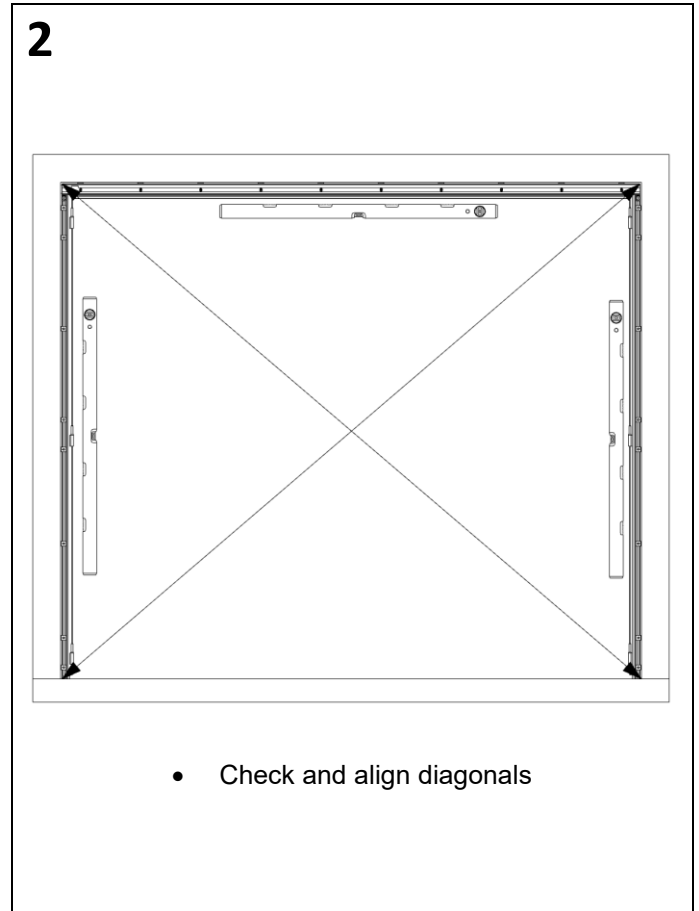
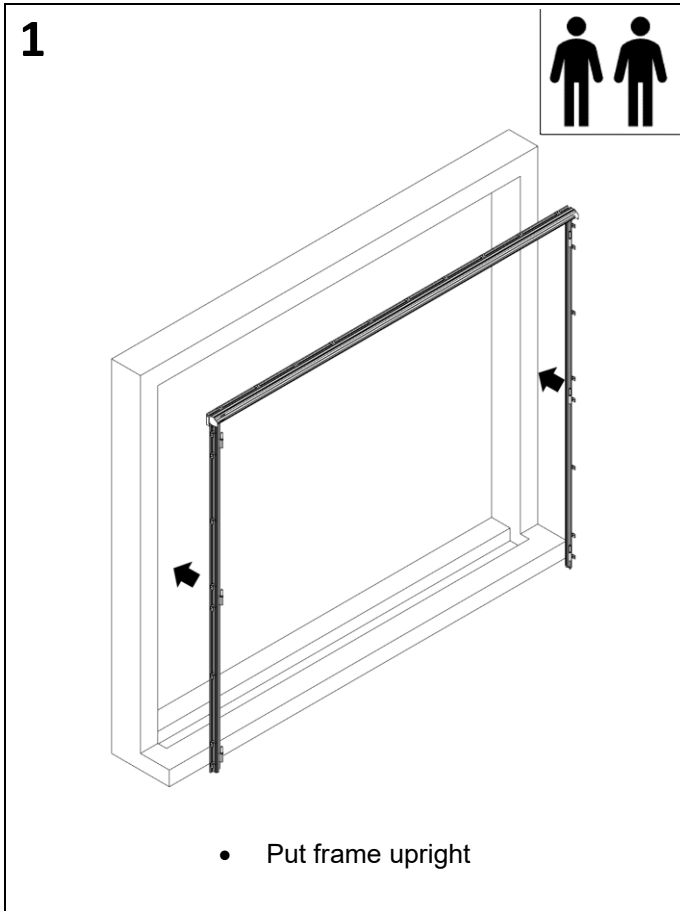

5

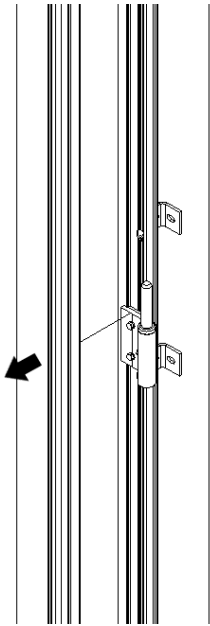

- Loosen the leaf seal in the area of the lowest hinge flap

6

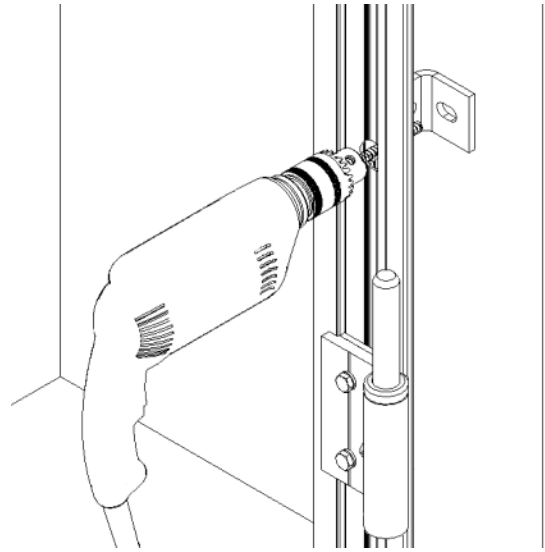

- Only drill and bolt the lowest bracket on the left and right
- Wait with drilling and bolting the other brackets until all leaves are installed

4.2.4 180° guide rail in front of/behind the soffit

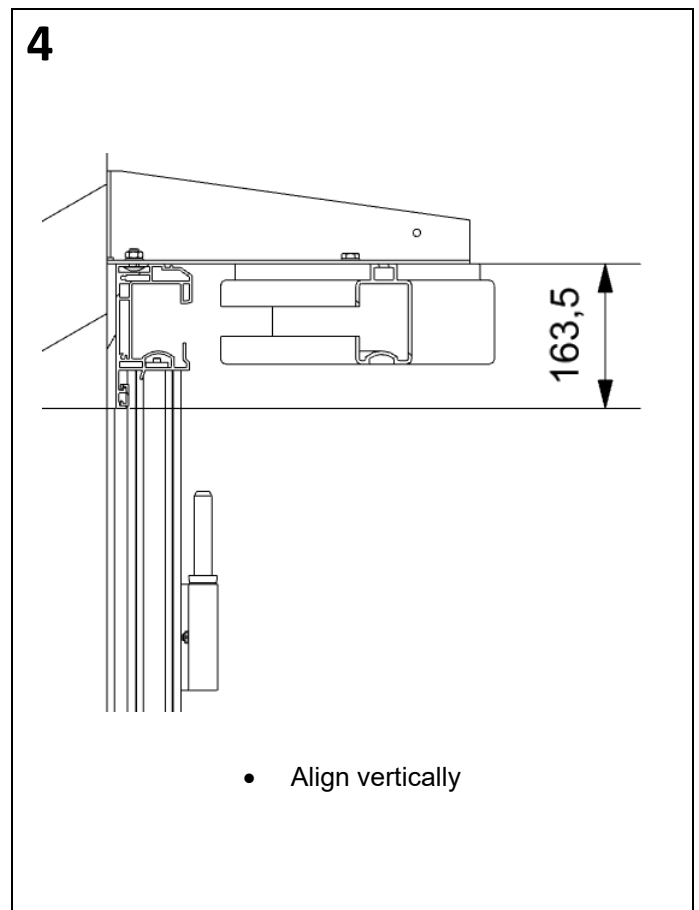
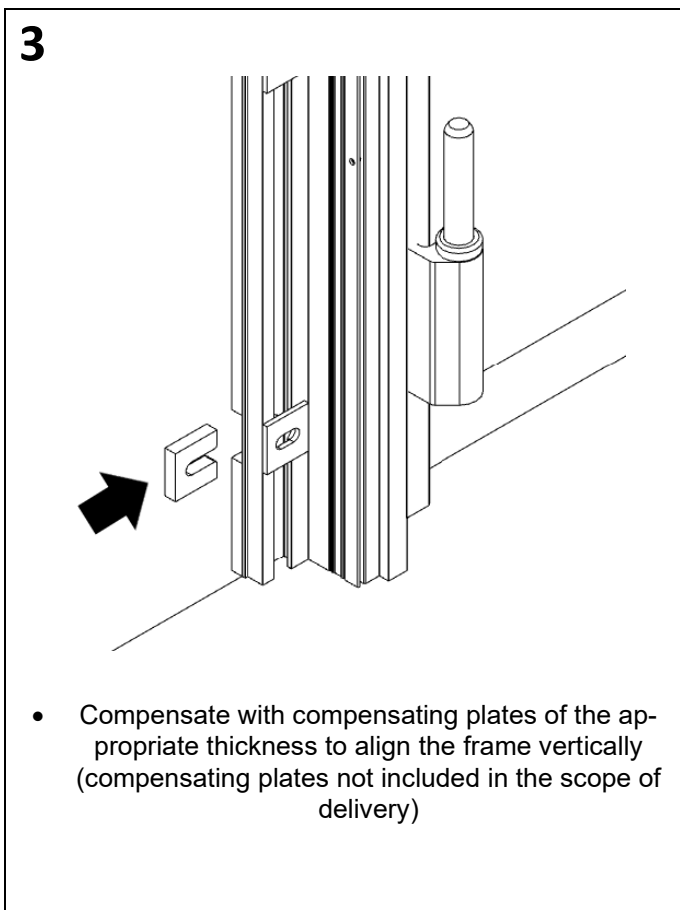
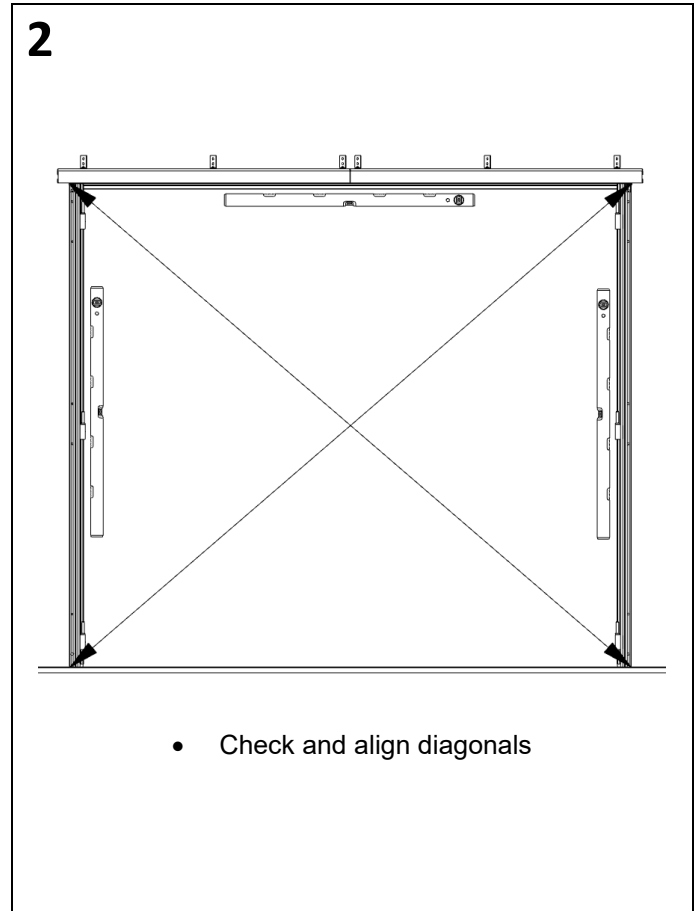
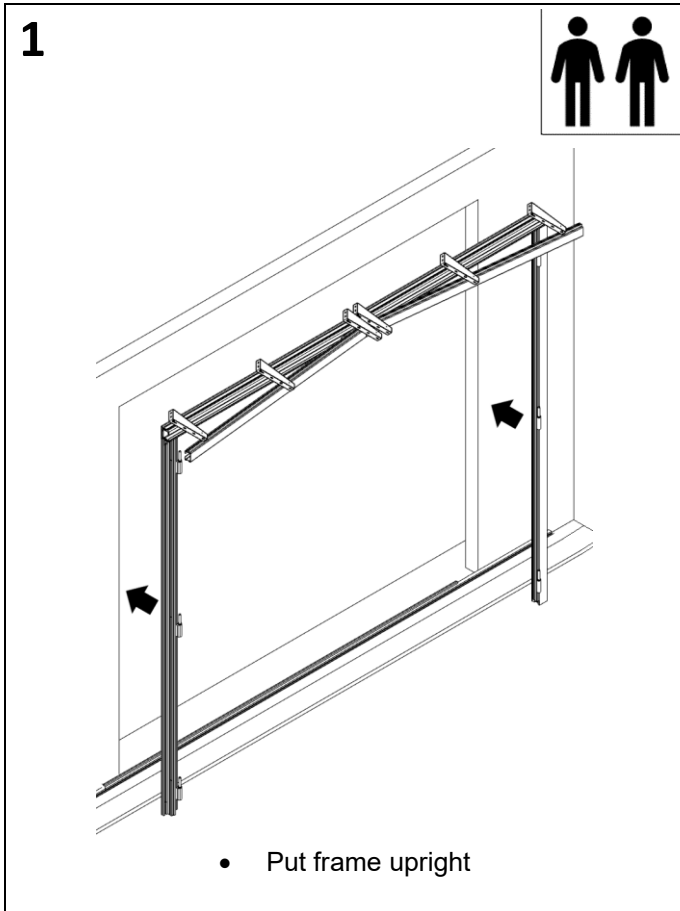

5

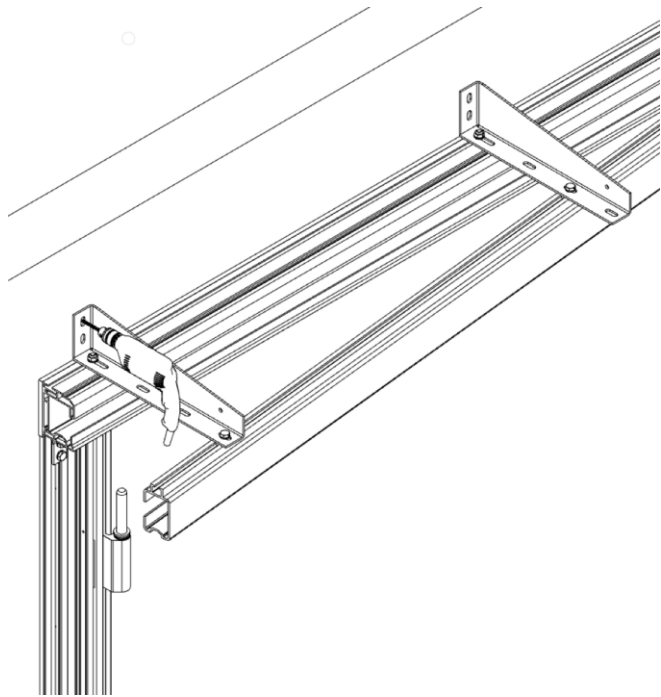

- Drill and bolt guide rail

6

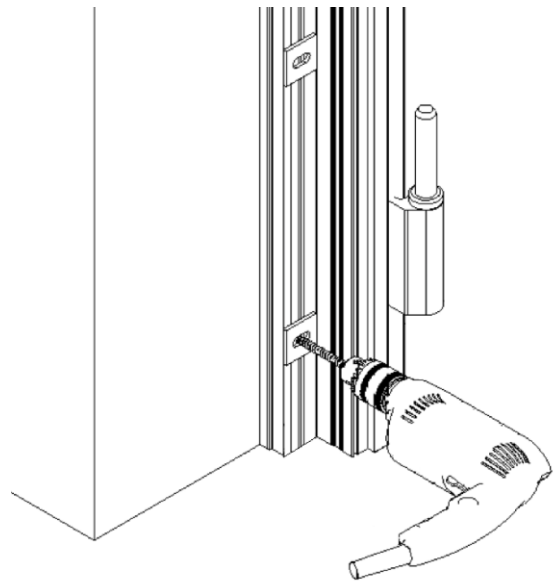

- Only drill through the lowest installation hole on the left and right and bolt the frame (fastening torque 30Nm)
- Wait with drilling and bolting the others until all leaves are installed

4.2.5 180° guide rail corner soffit

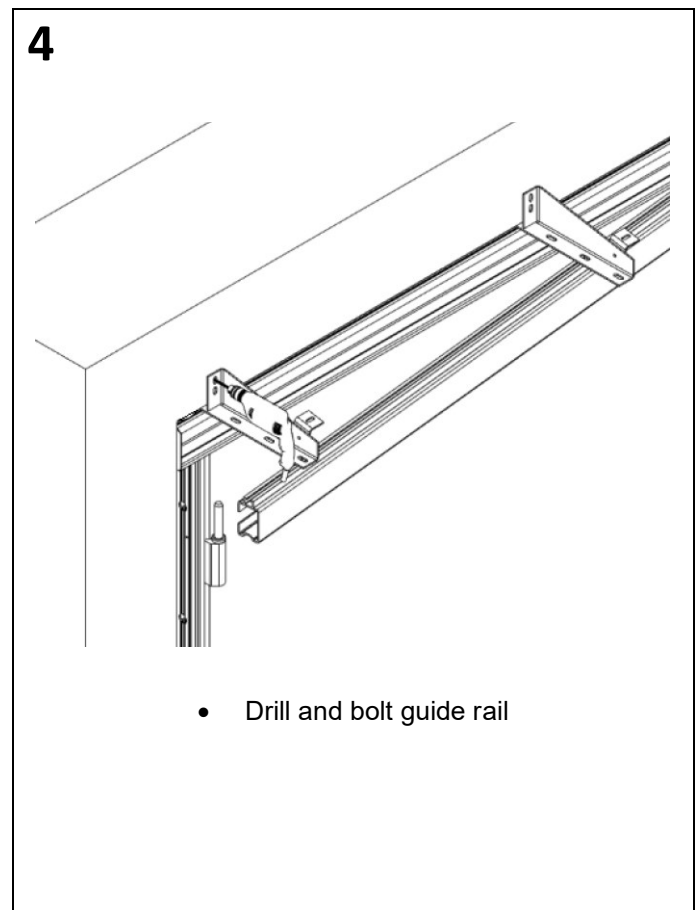
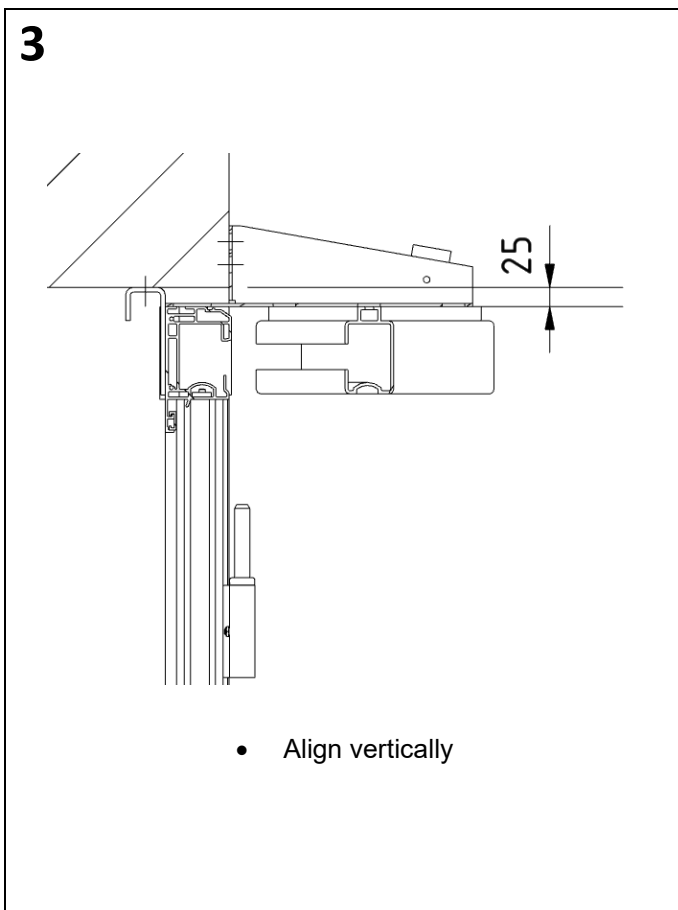
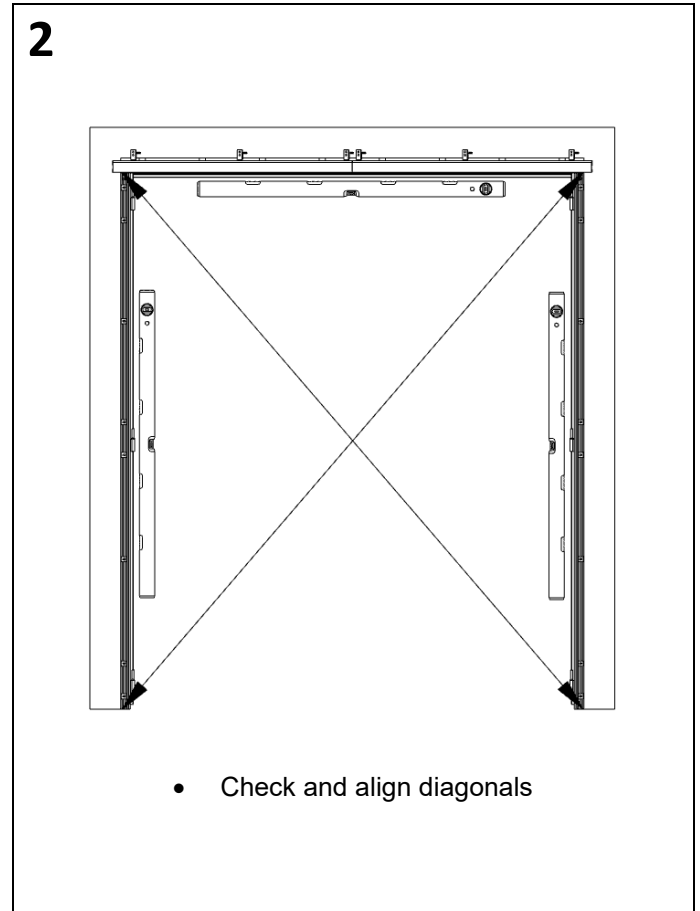
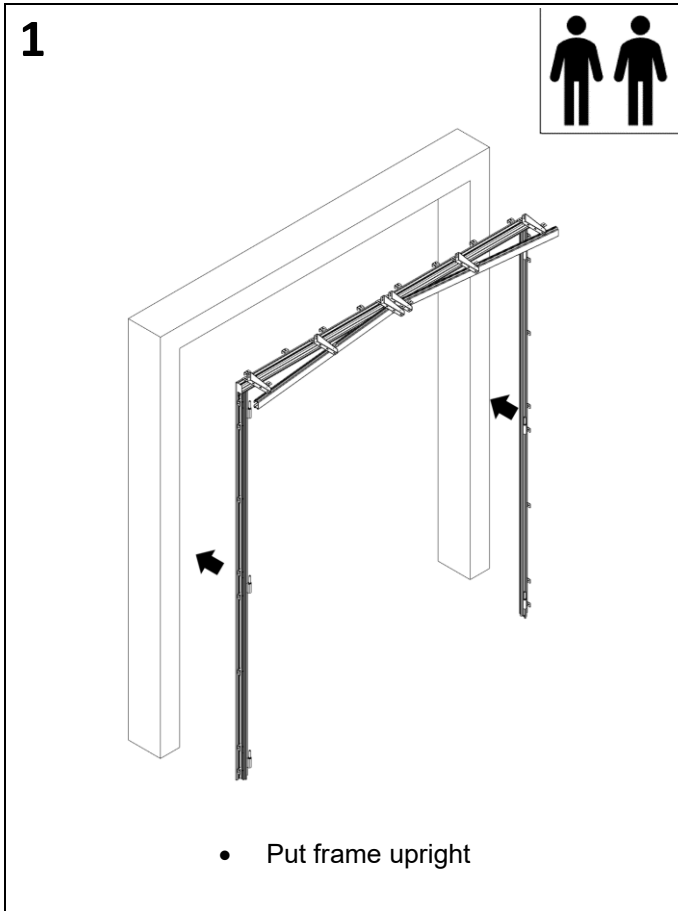

5

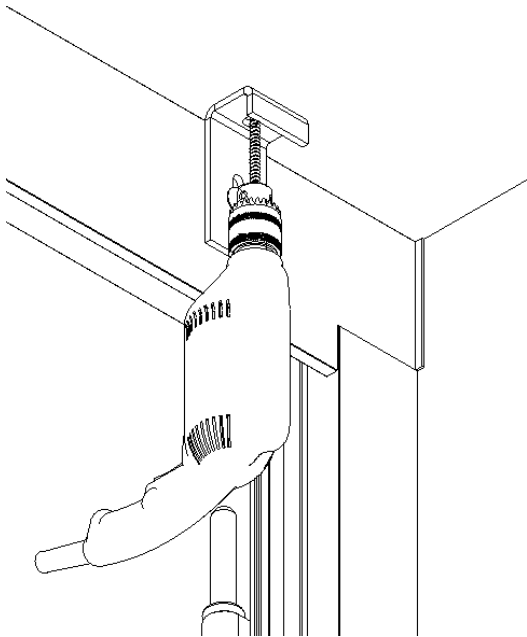

- Drill and bolt guide rail bracket

6

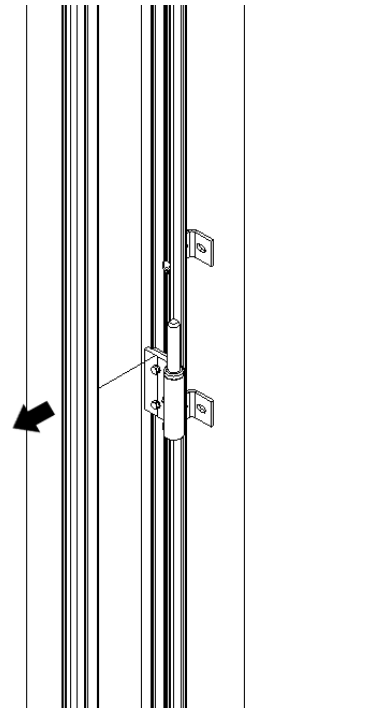

- Loosen the leaf seal in the area of the lowest hinge flap

7

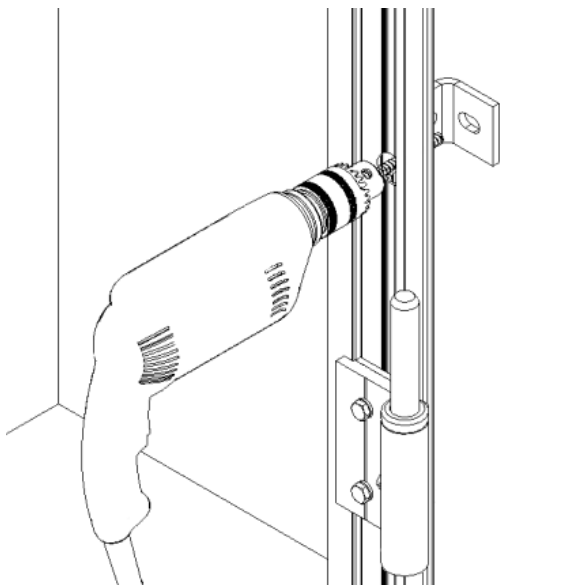

- Only drill and bolt the lowest bracket on the left and right
- Wait with drilling and bolting the other brackets until all leaves are installed

4.3 Ground guide rails

4.3.1 BF-light NIRO ground guide

1

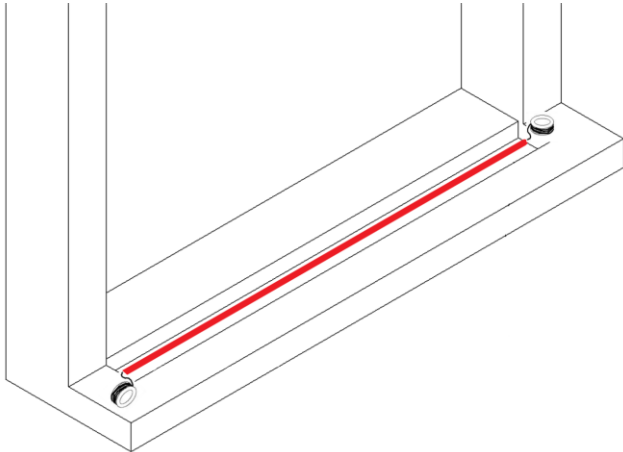

- Mark the dimensions from the soffit edges to the outer edge of the ground guide rail on both sides and connect using a chalk line (for dimensions see blueprints)

2

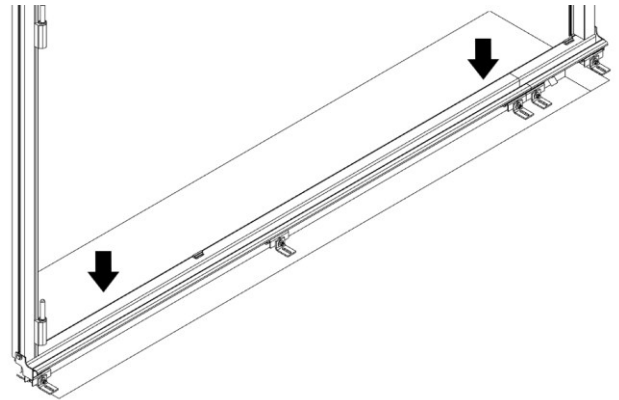

- Place the ground guide rail

3

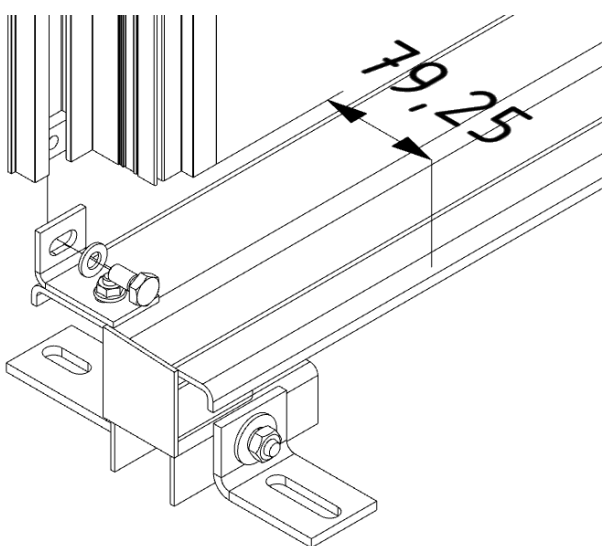
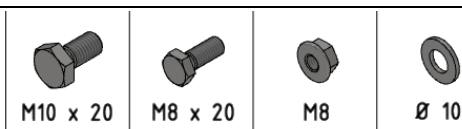

- Bolt the ground guide rail to the frame parts

4

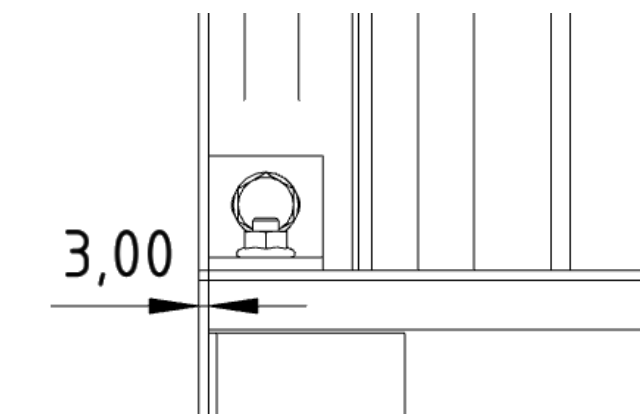

- Symmetrical offset frame – ground guide rail

5

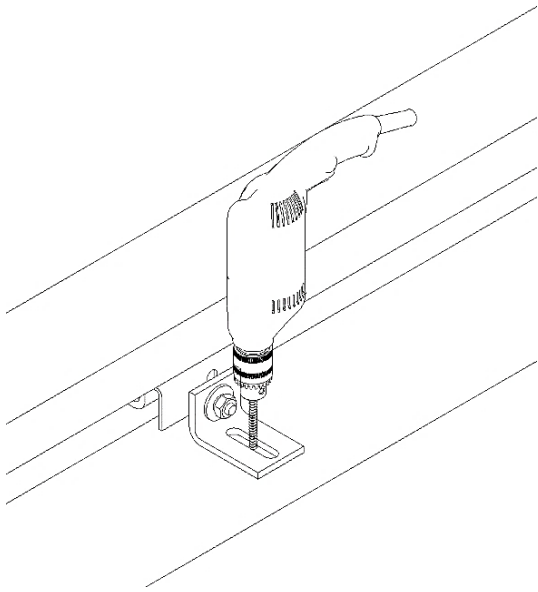

- Pre-mount starting in the centre

6

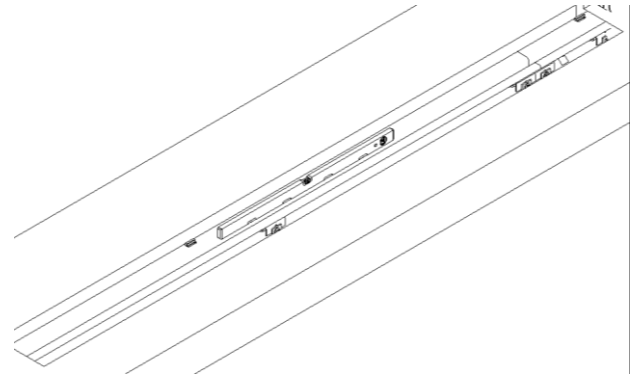

- Level at height according to blueprints and securely anchor

Note: see 4.8 for RC2/WK2 version

4.3.2 DA threshold

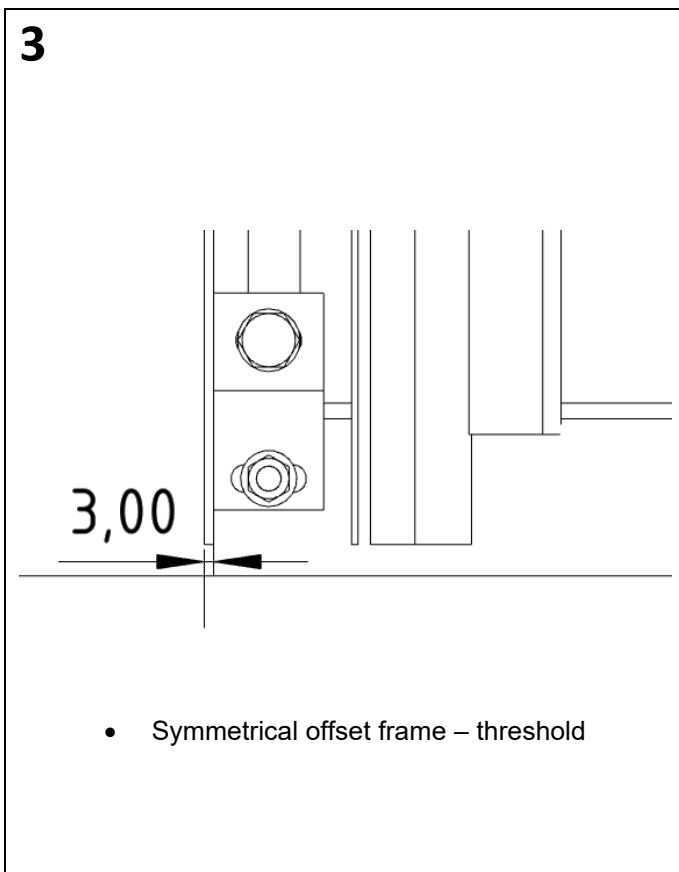
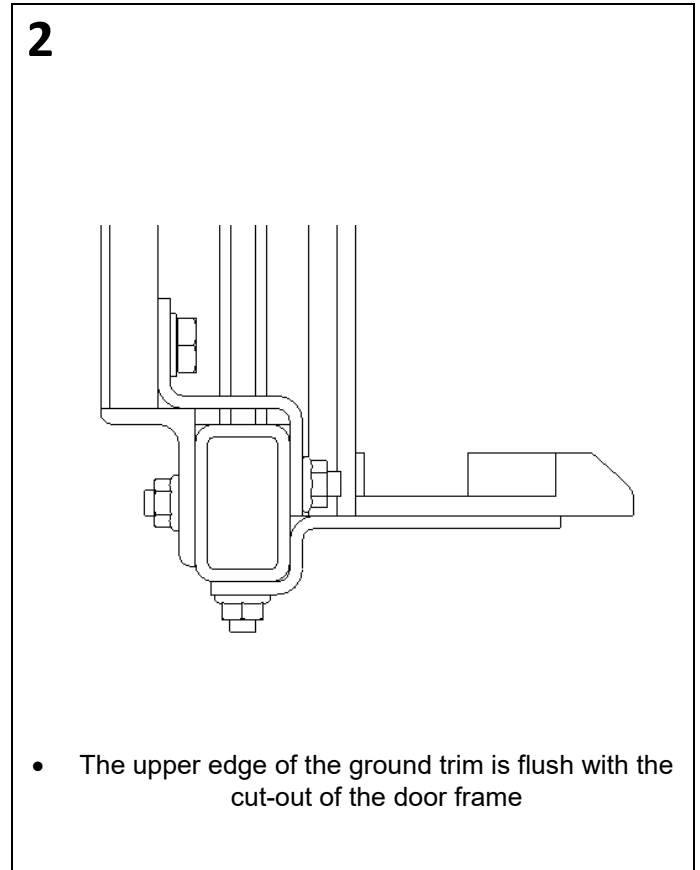
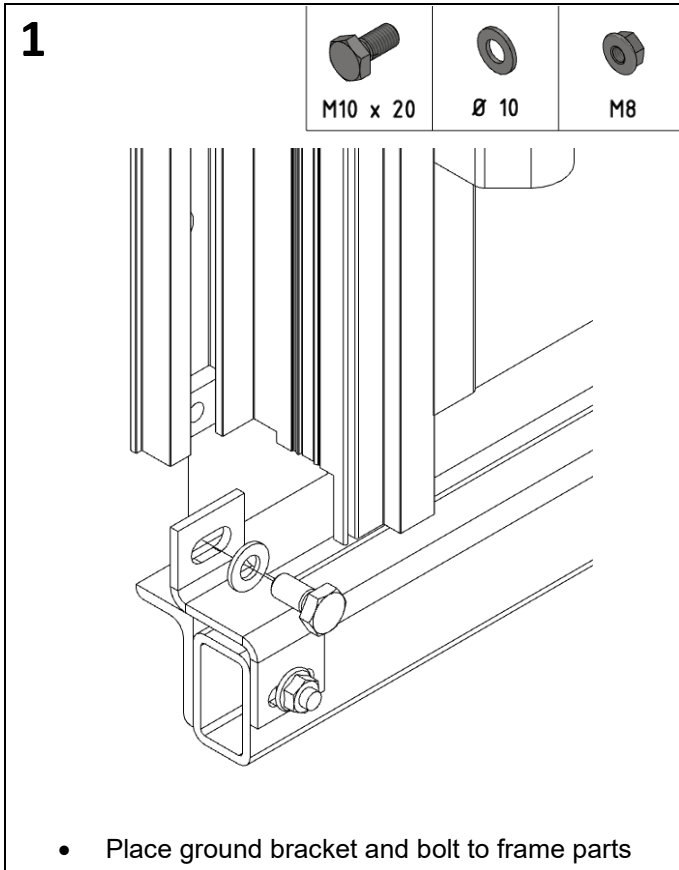

4.3.3 20D threshold

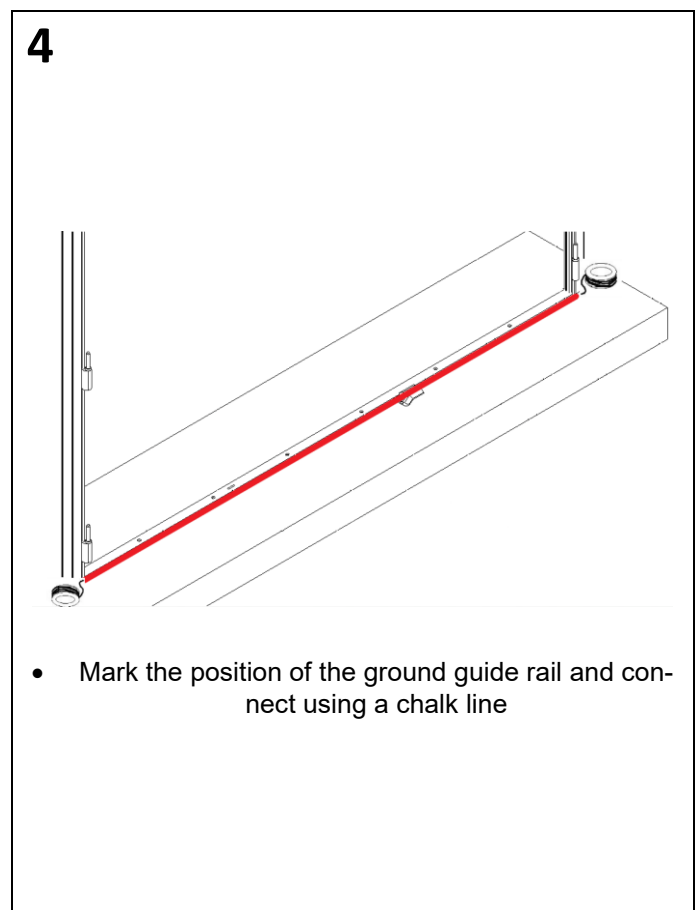
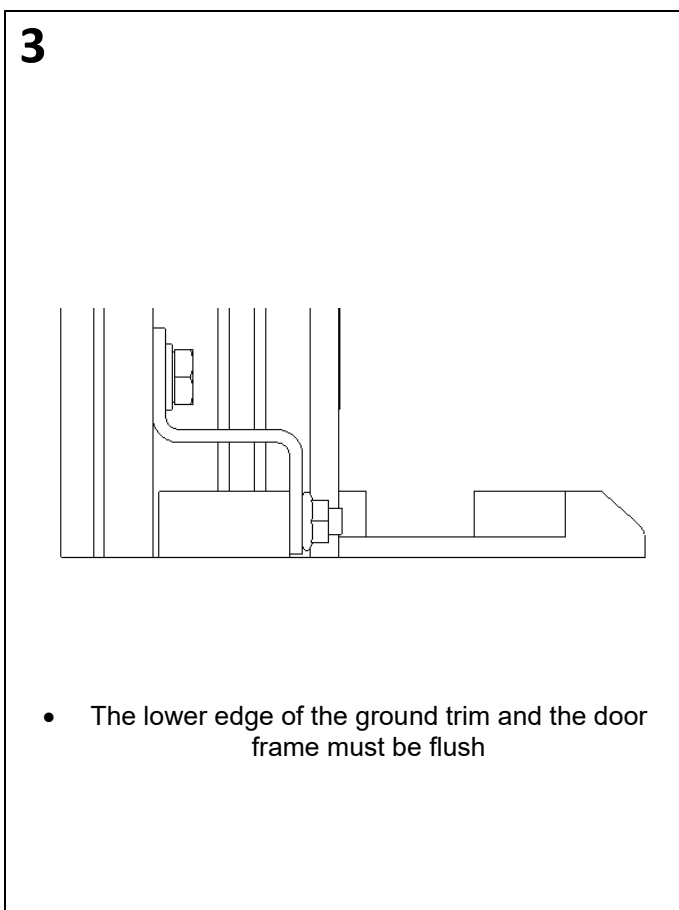
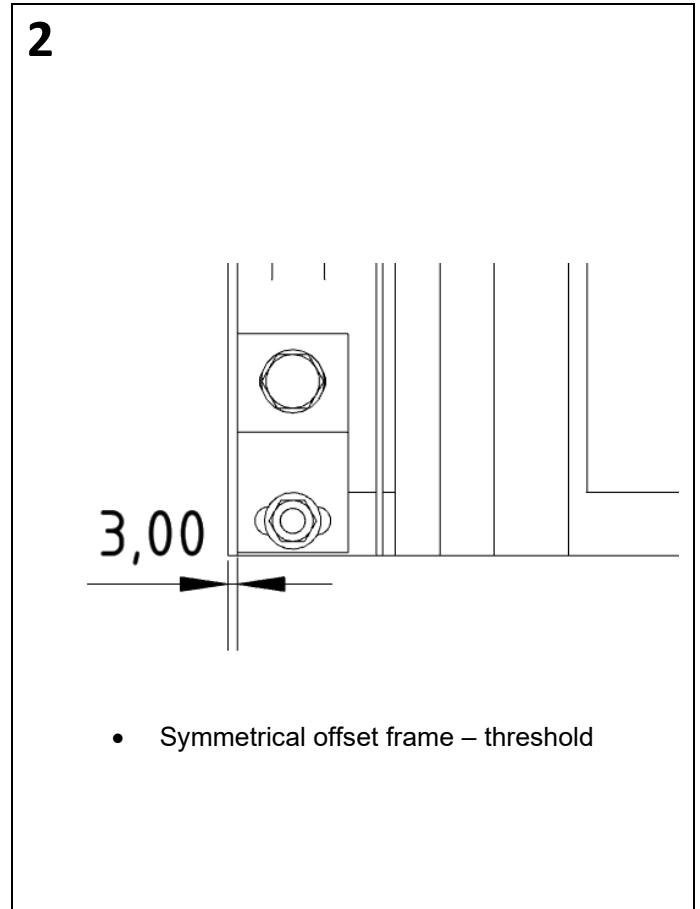
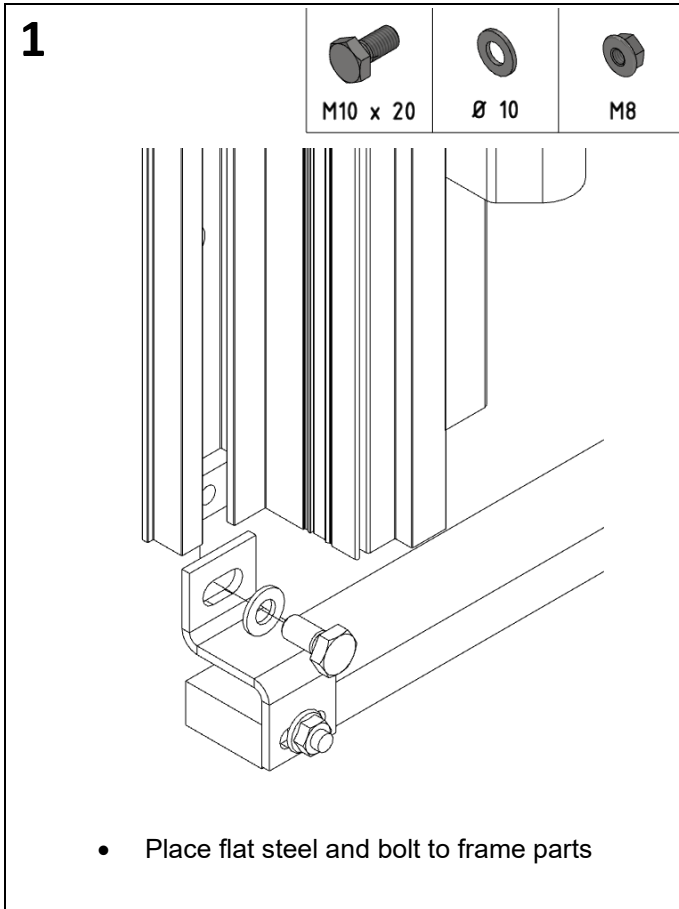

5

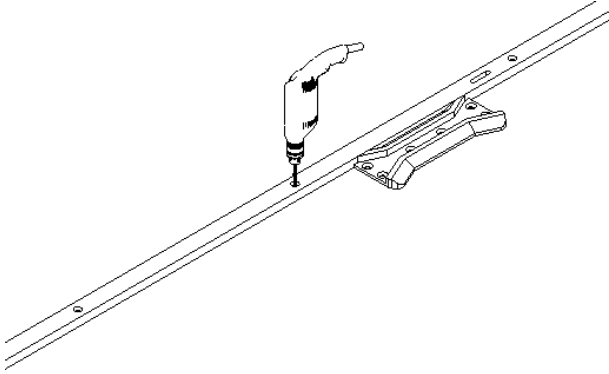

- Pre-mount and bolt starting in the centre

6

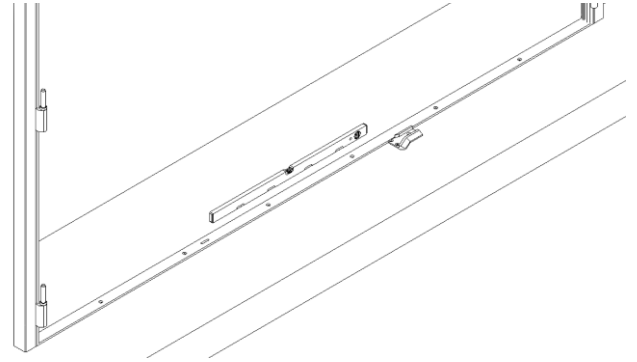

- Level at height according to blueprints and securely anchor

Note: see 4.8 for RC2/WK2 version

4.4 Door leaf installation

4.4.1 Even number of leaves

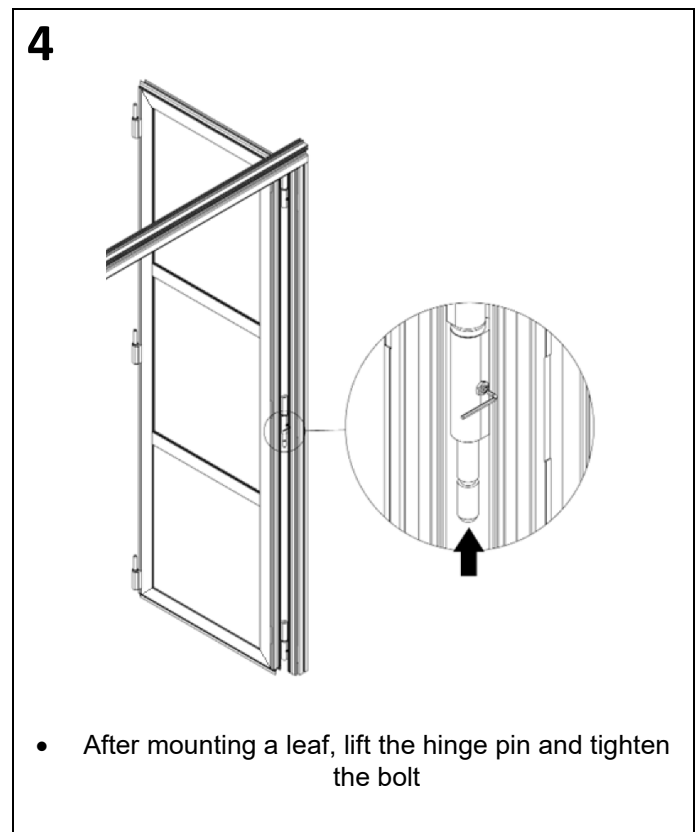
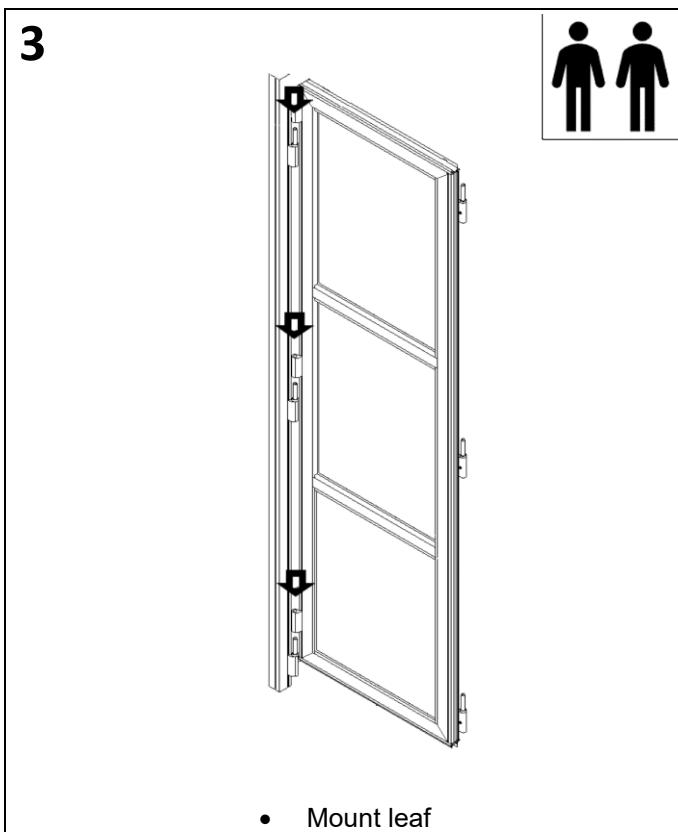
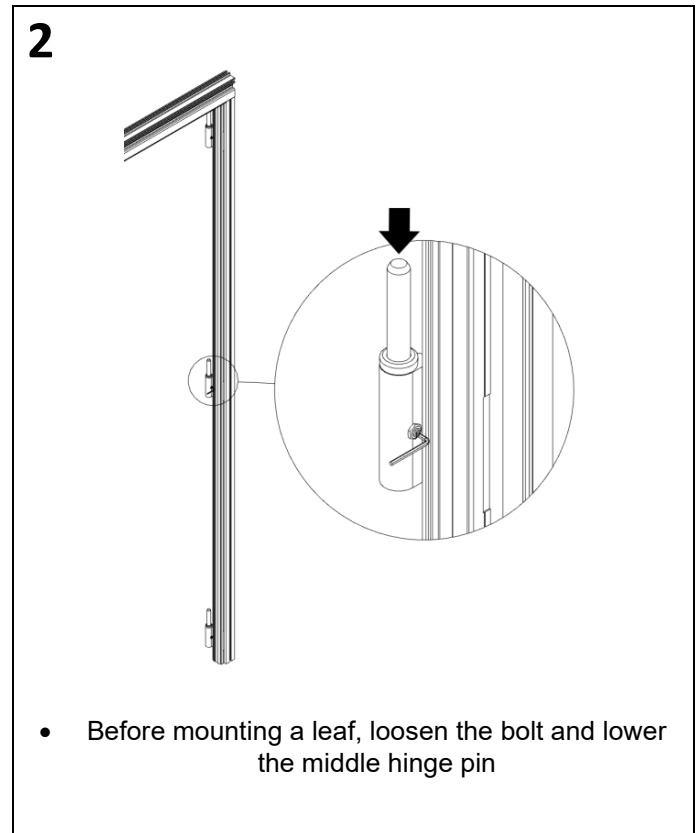
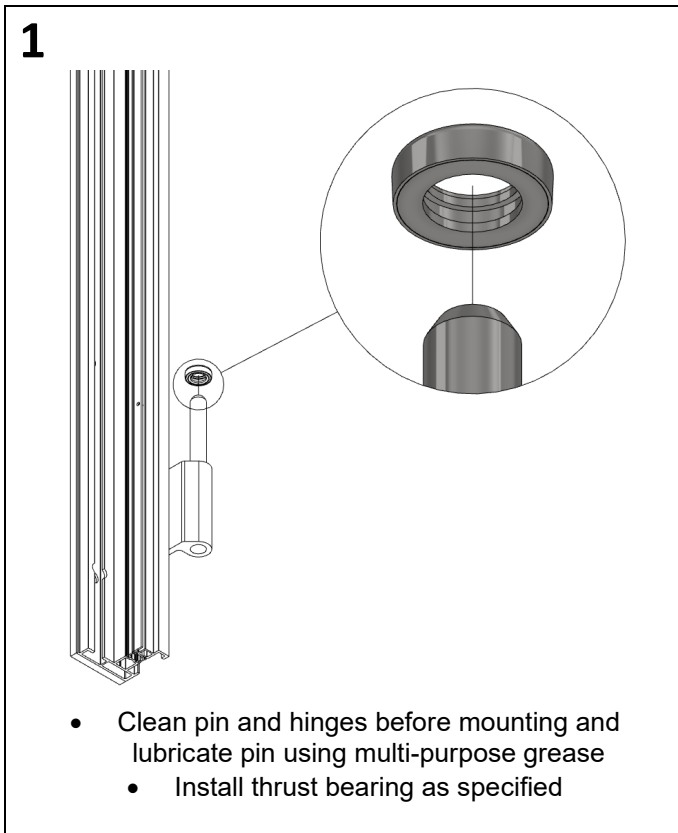

5

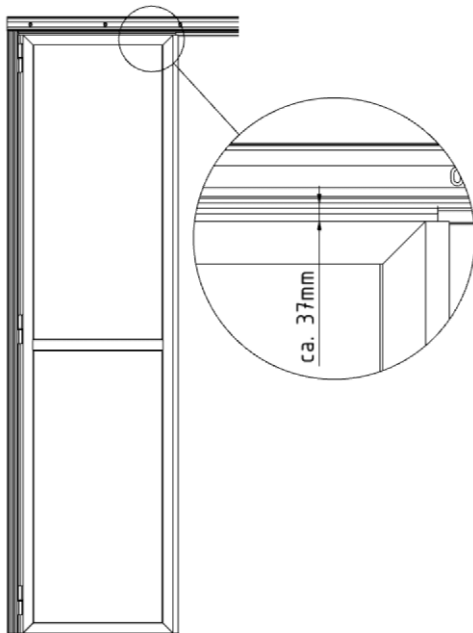

- Adjust the distance between the leaf and the guide rail across the whole width of the leaf

6

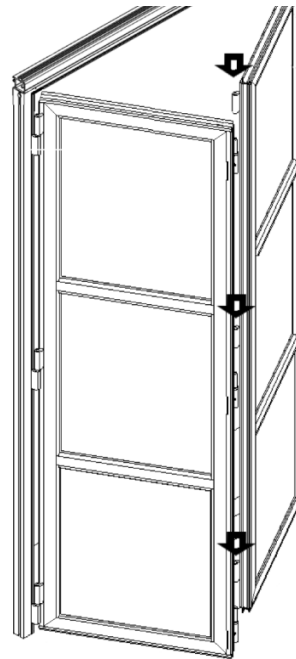

- Support first leaf

7

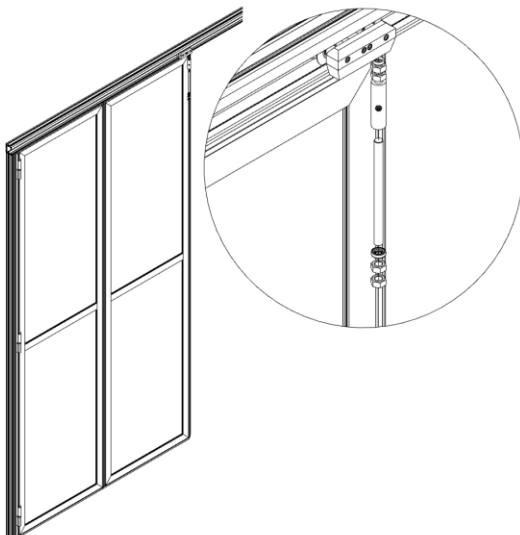

- Mount running gear at every second leaf of a leaf set
- For a 4-leaf set, mount the small running gear as the end drive
 - **Note:** see 4.8 for RC2/WK2 version

8

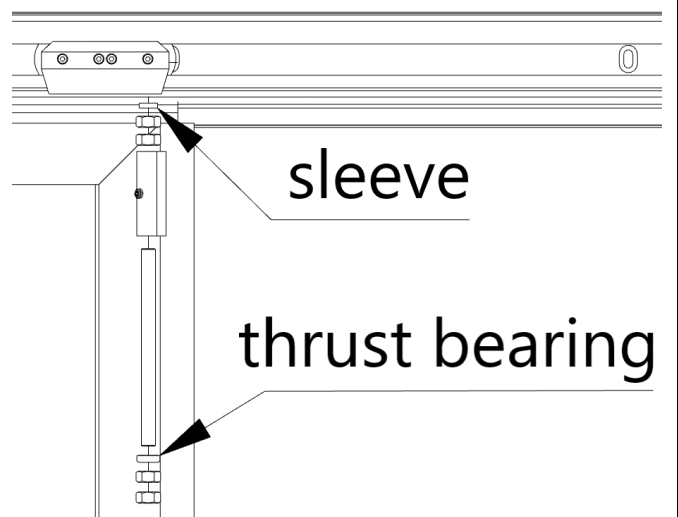
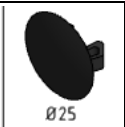

- Insert the cover cap into the two remaining holes in the running gear

9

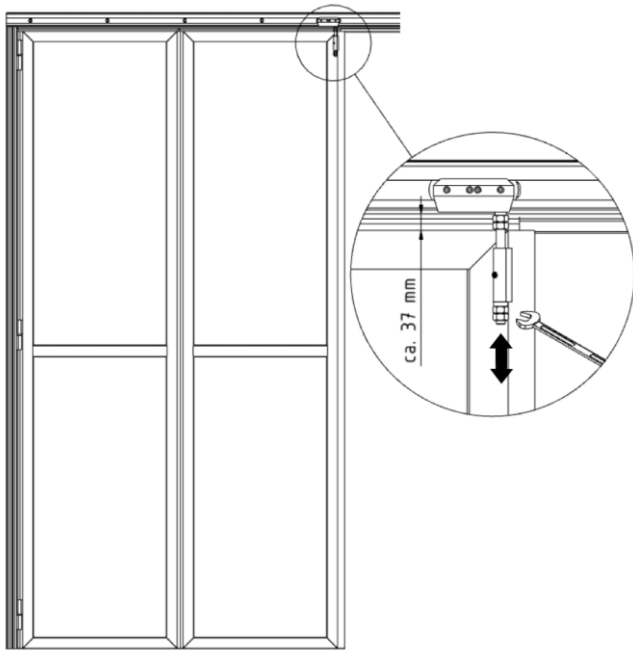

- Adjust the distance between the leaf and the guide rail across the whole width of the leaf (secure nuts)

10

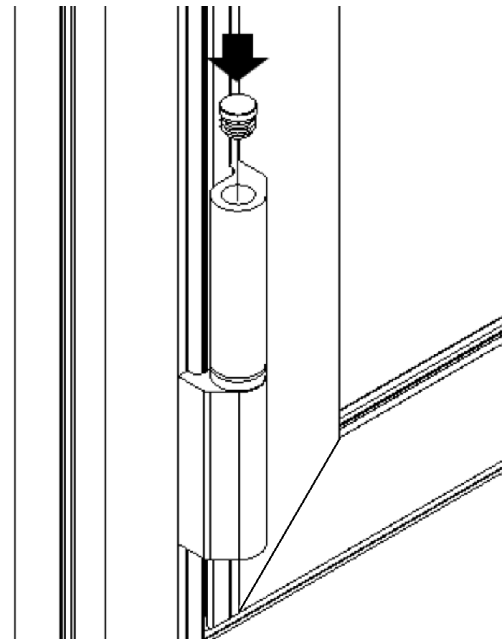

- Install lamella plugs on every hinge after completed installation

11

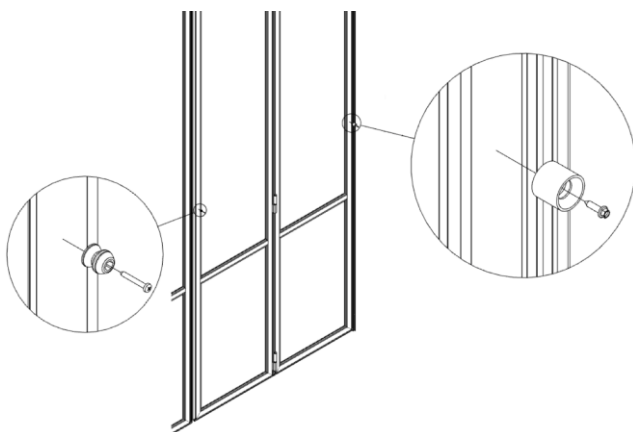

- Always install the rubber buffers maximally central between the leaves to avoid collisions in open position

12

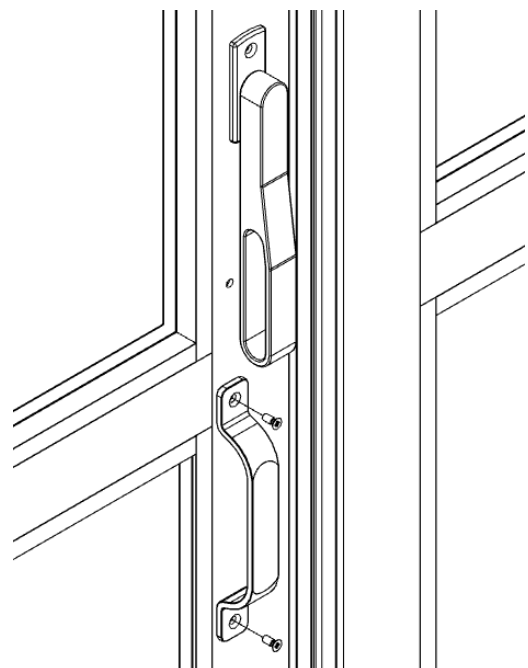

- Install handle below loop handle

4.4.2 Uneven number of leaves

1

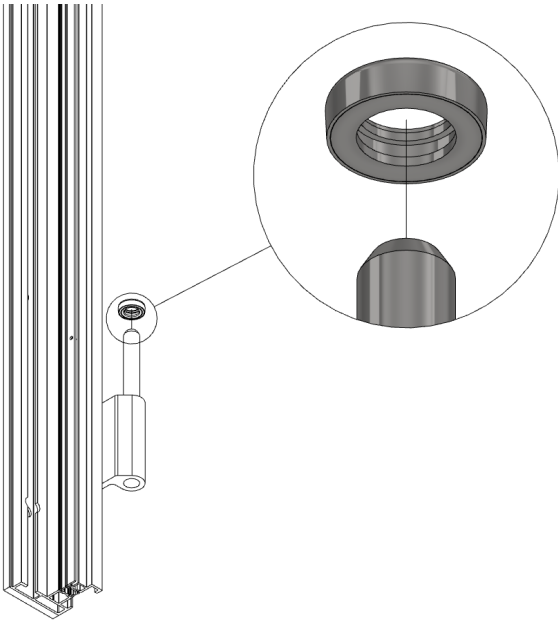

- Clean pin and hinges before mounting and lubricate pin using multi-purpose grease
 - Install thrust bearing as specified

2

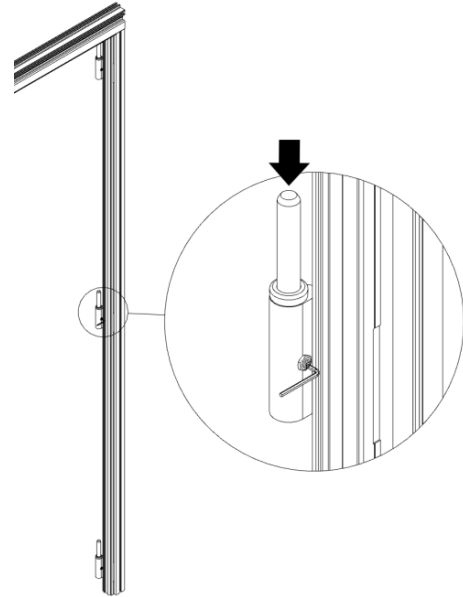

- Before mounting a leaf, loosen the bolt and lower the middle hinge pin

3

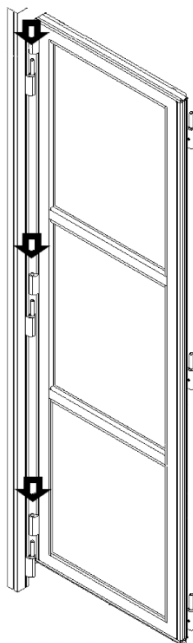

- Mount leaf

4

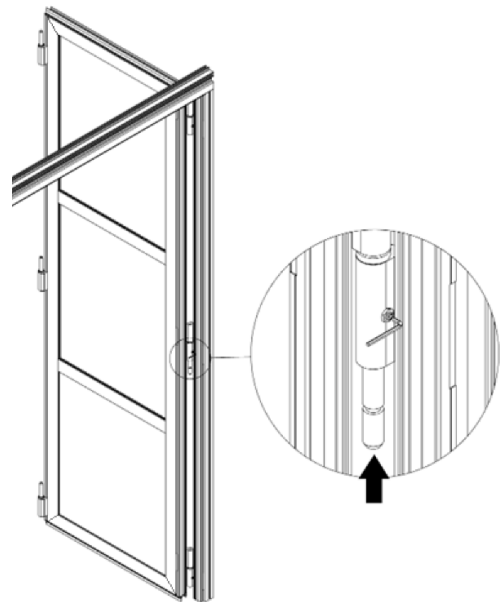

- After mounting a leaf, lift the hinge pin and tighten the bolt

5

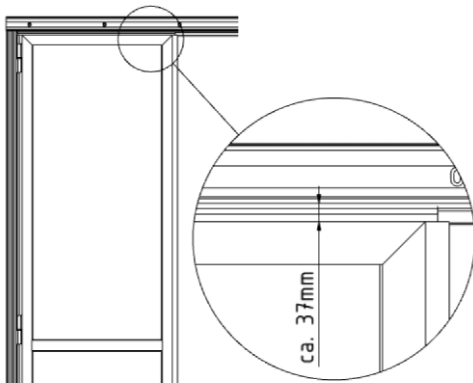

- Adjust the distance between the leaf and the guide rail across the whole width of the leaf

6

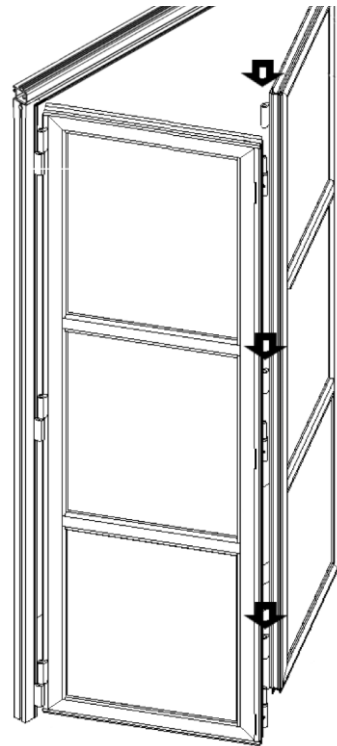

- Support first leaf

7

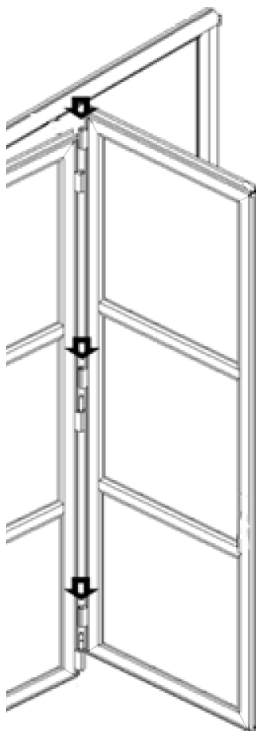

- Support first and second leaf

8

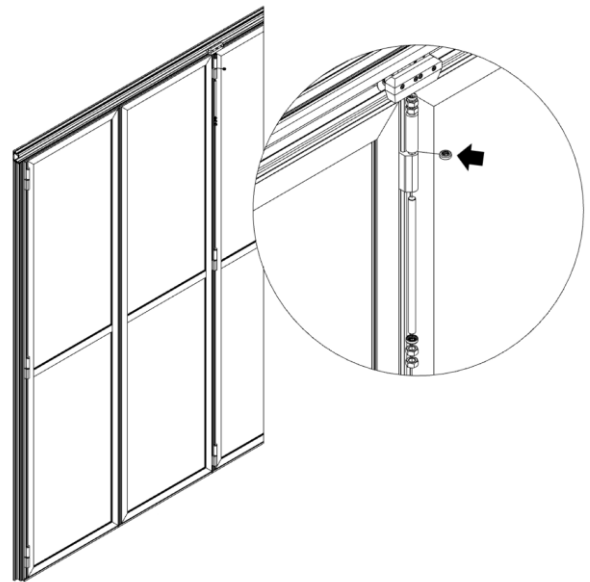

- Mount running gear at every second leaf of a leaf set
- **Note:** see 4.8 for RC2/WK2 version

9

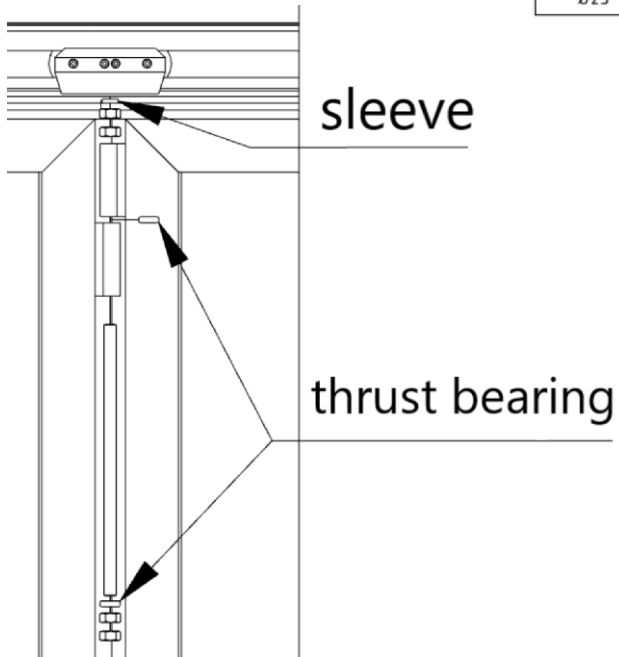

- Insert the cover cap into the two remaining holes in the running gear

10

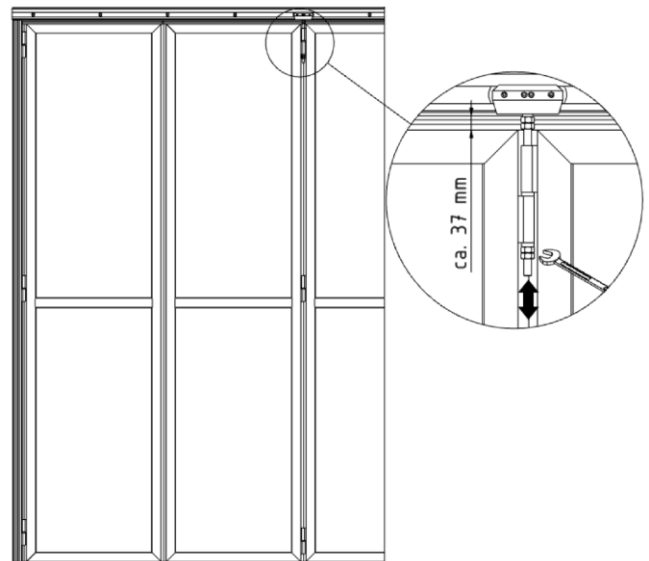

- Adjust the distance between the leaf and the guide rail across the whole width of the leaf (secure nuts)

11

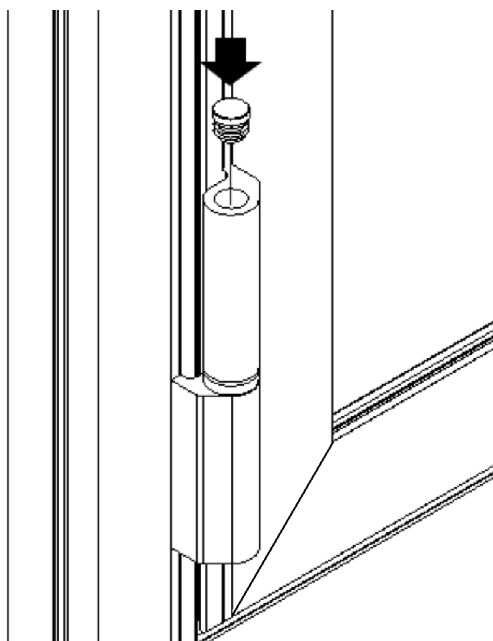

- Install lamella plugs on every hinge after completed installation

12

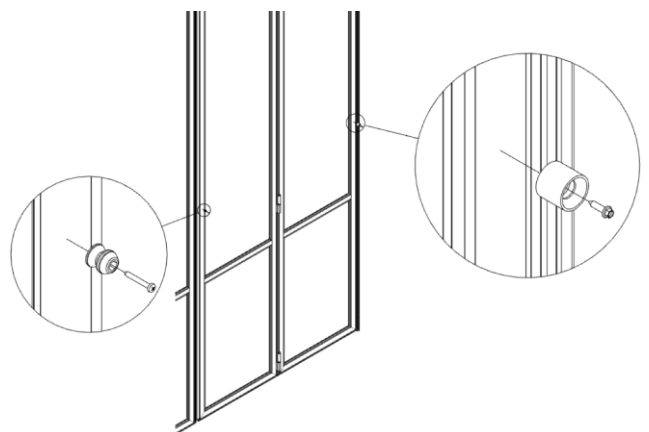

- Always install the rubber buffers maximally central between the leaves to avoid collisions in open position

13

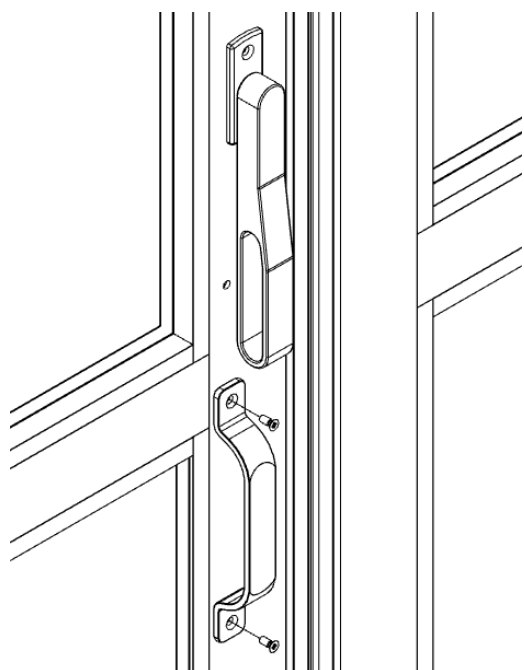

- Install handle below loop handle

4.4.3 Door hinge installation for individual leaves

1

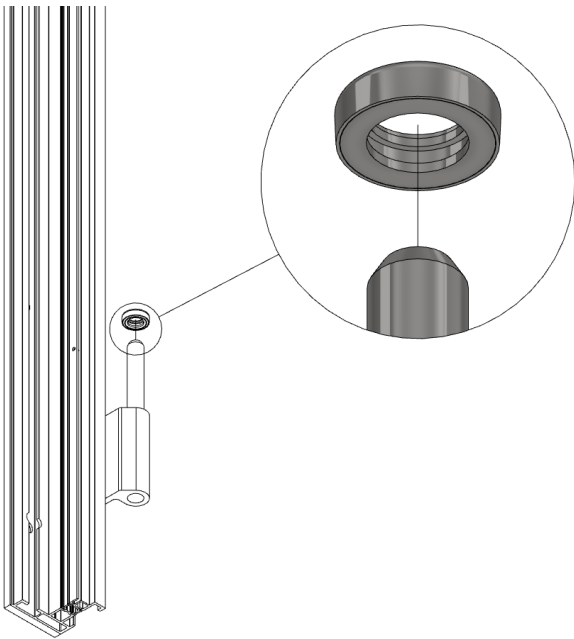

- Clean pin and hinges before mounting and lubricate pin using multi-purpose grease
- Install thrust bearing as specified

2

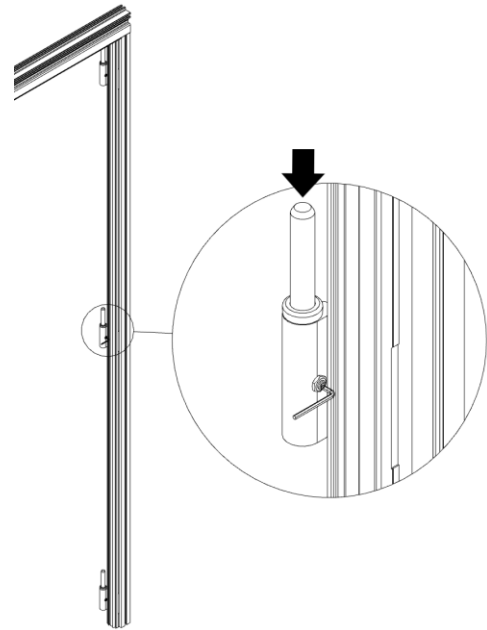

- Before mounting the leaf, loosen the bolt and lower the middle hinge pin

3

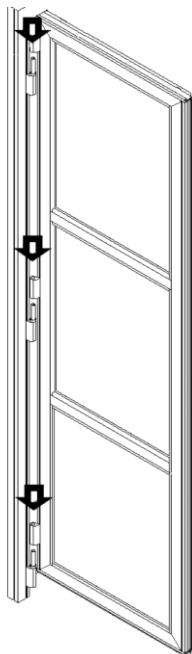

- Mount leaf

4

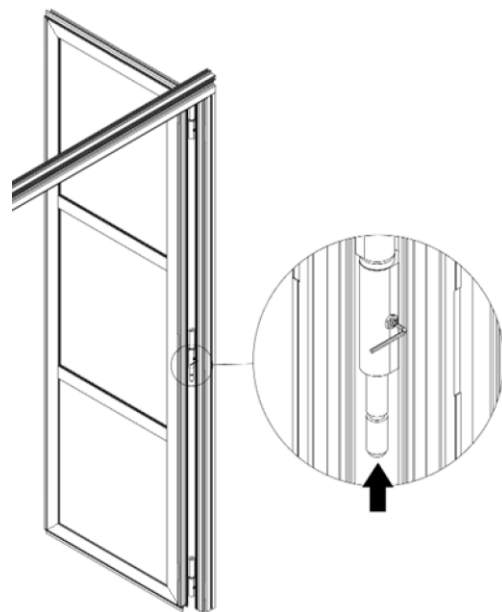

- After mounting the leaf, lift the hinge pin and tighten the bolt

5

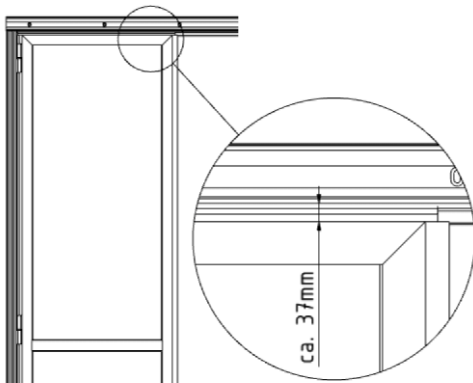

- Adjust the distance between the leaf and the guide rail across the whole width of the leaf

6

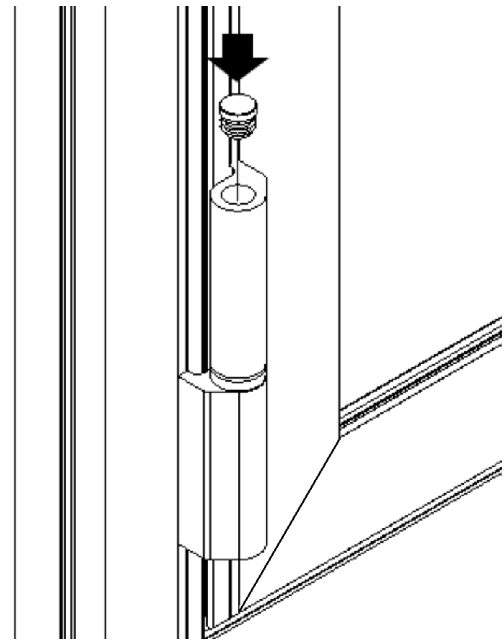

- Install lamella plugs on every hinge after completed installation

7



M5 x 20

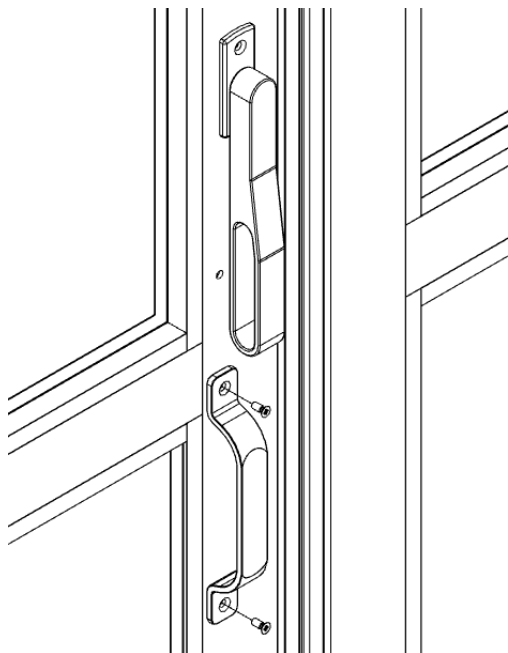

- Install handle below loop handle

4.4.4 Active leaf/walk-through door pusher/door knob

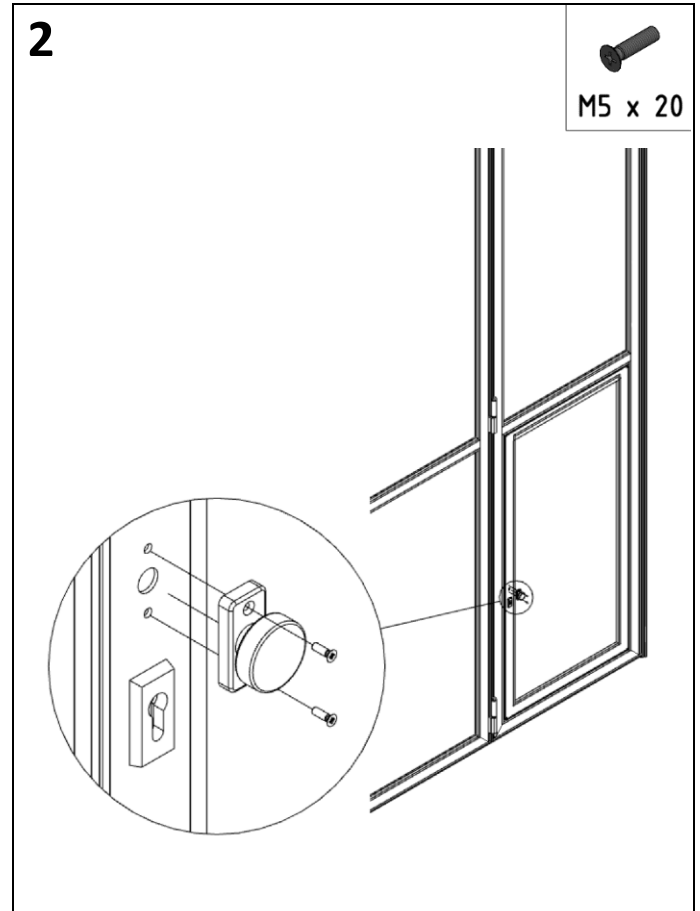
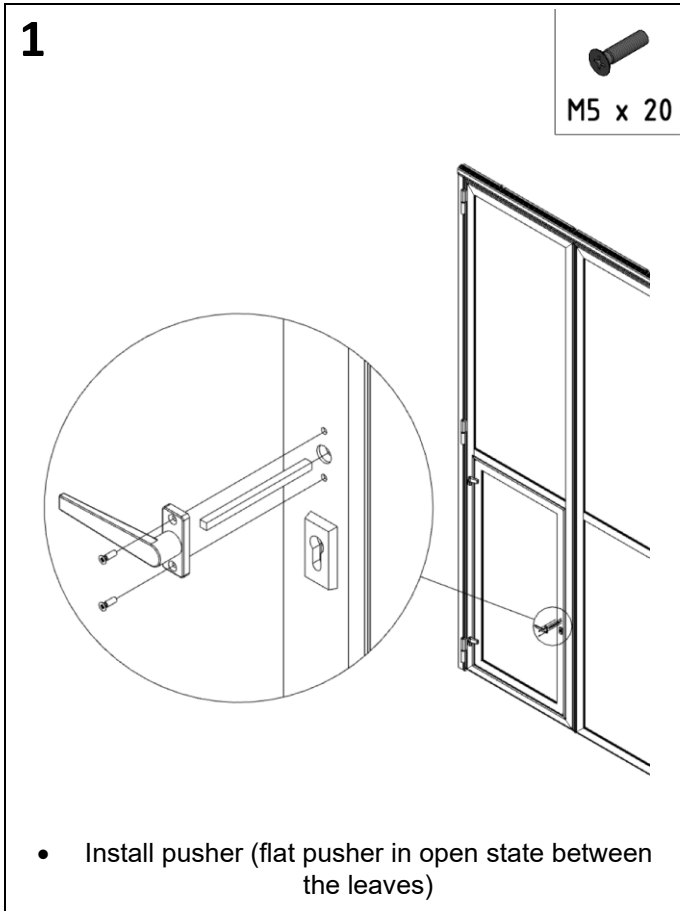

4.5 Frame fine adjustment

1

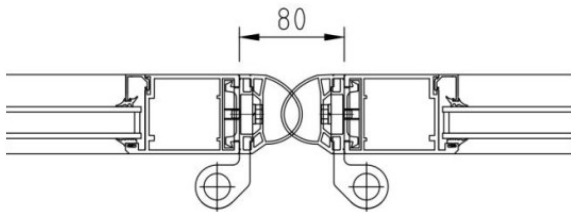

Even leaf partition (hand-operated)

- Check spacing between the middle leaves
- If incorrect, the door frame must be readjusted

2

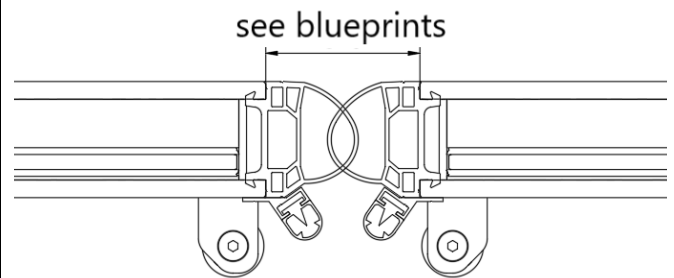

Mechanically operated

3

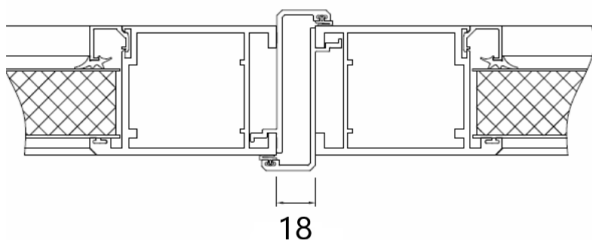

Uneven leaf partition (hand-operated)

4

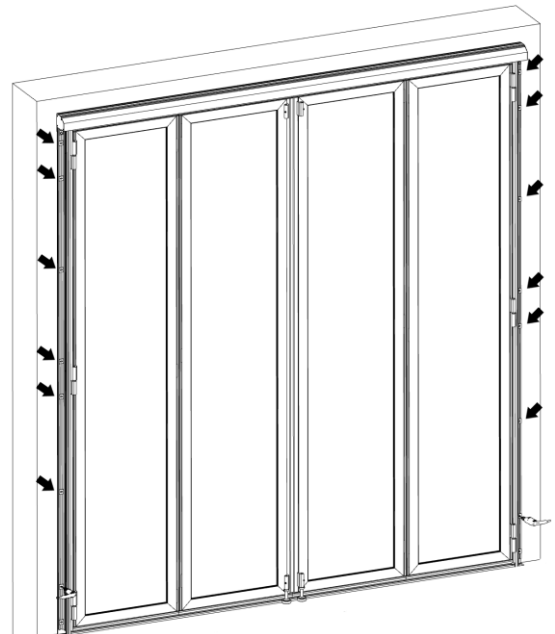

- Otherwise, bolt the rest of the door frame holes or brackets (fastening torque 30Nm)
- One bracket above and below each hinge flap and one bracket in the middle between the hinge flaps
 - **Note:** see 4.8 for RC2/WK2 version

4.6 Sheet metal cover installation

4.6.1 90° guide rail in front of/behind the soffit

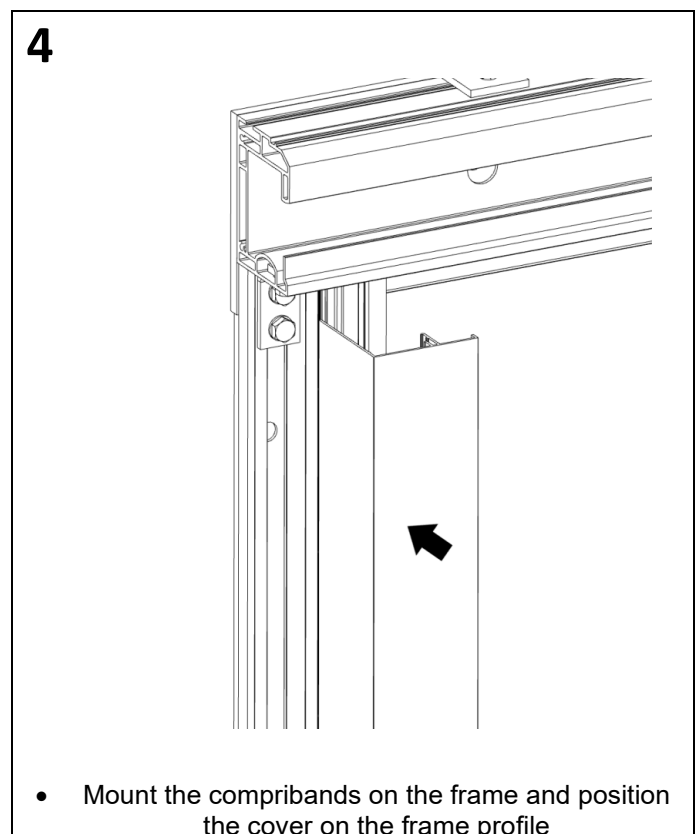
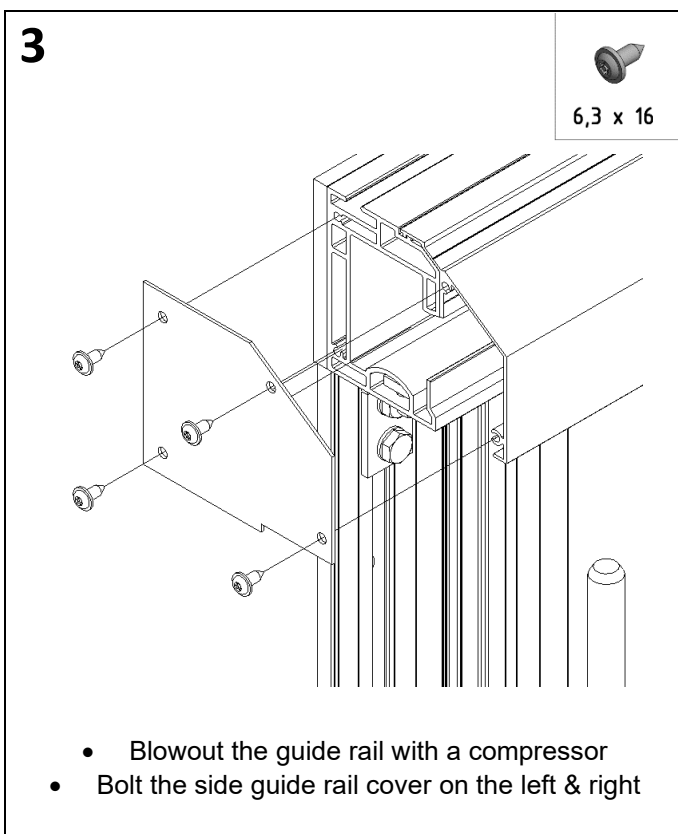
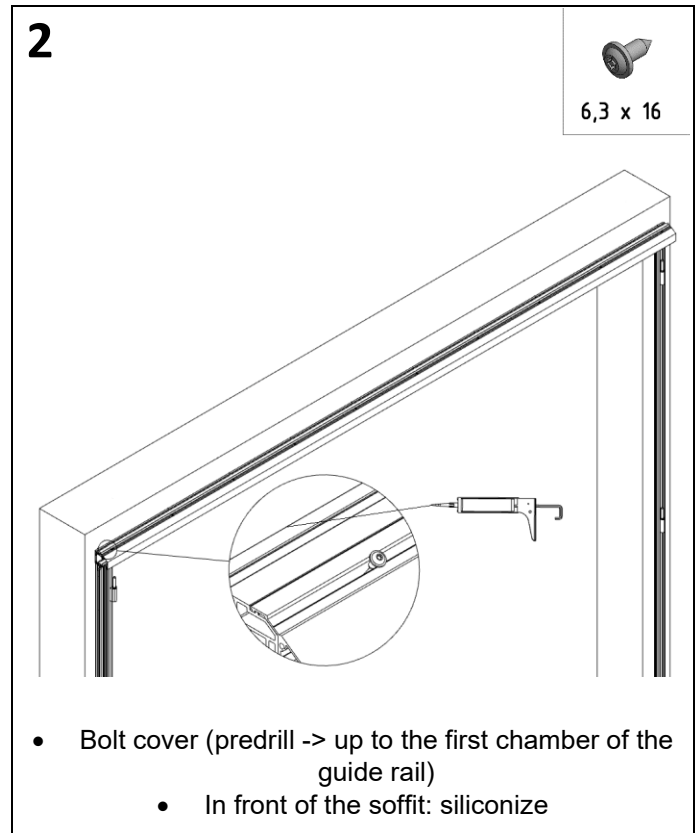
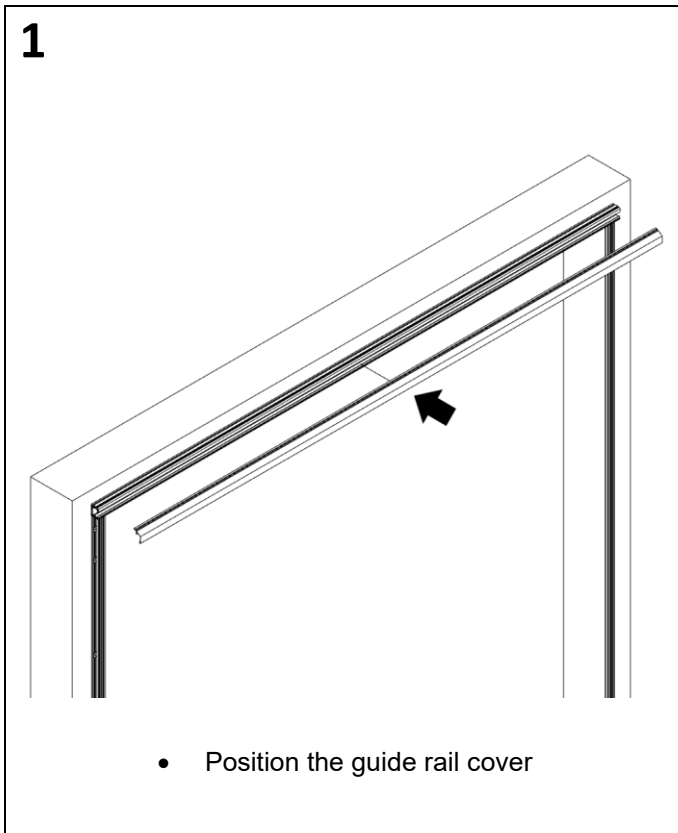

5

cover

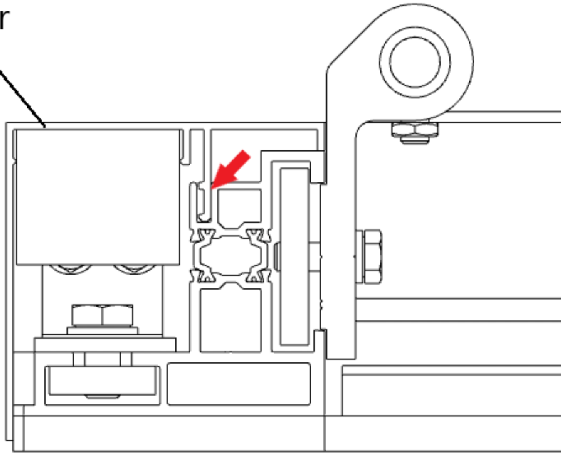

- Attention: position the cover correctly in the frame profile

6

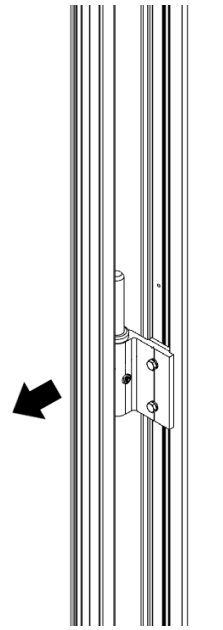

- Loosen the leaf seal in the area of approx. 85mm above each hinge flap of the frame profile

7

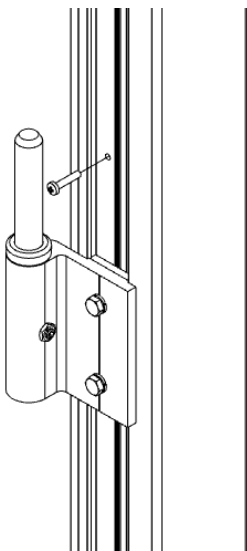

- Bolt the cover using a self-tapping screw and the factory-made holes and fix the leaf seal again

4.6.2 90° guide rail in the soffit

1

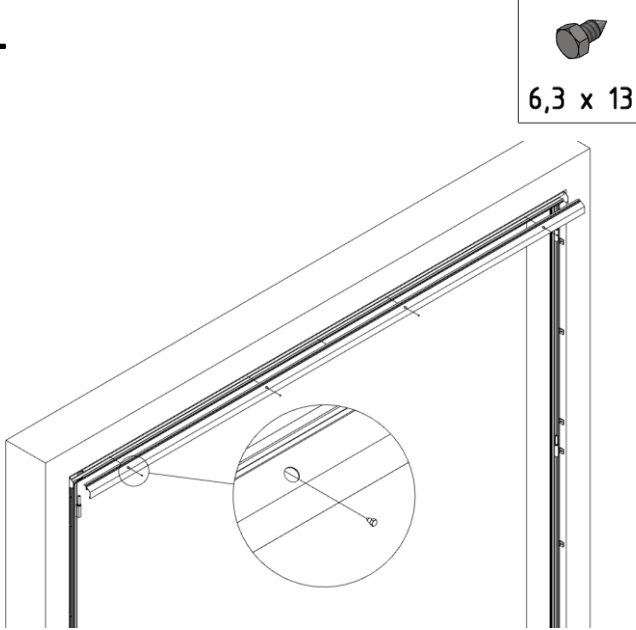

6,3 x 13

- Position the outer guide rail cover and bolt through the installation holes (predrill -> up to the first chamber of the guide rail)

2

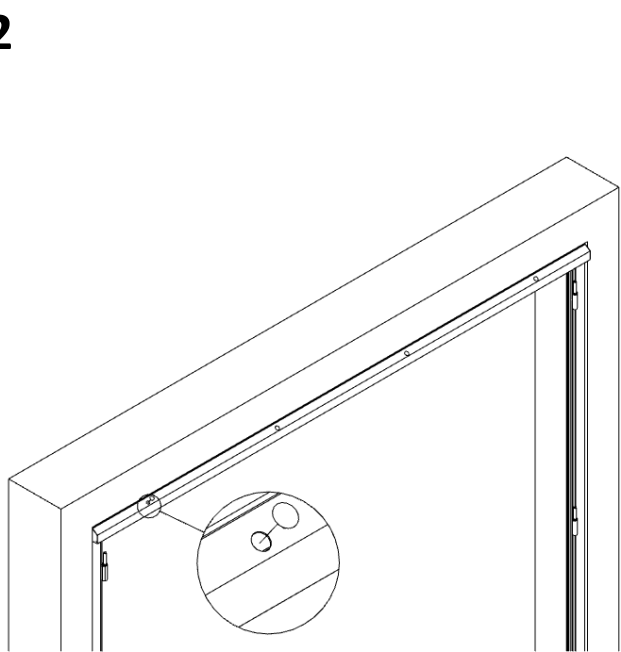

- Install the cover cap in each installation hole of the guide rail

3

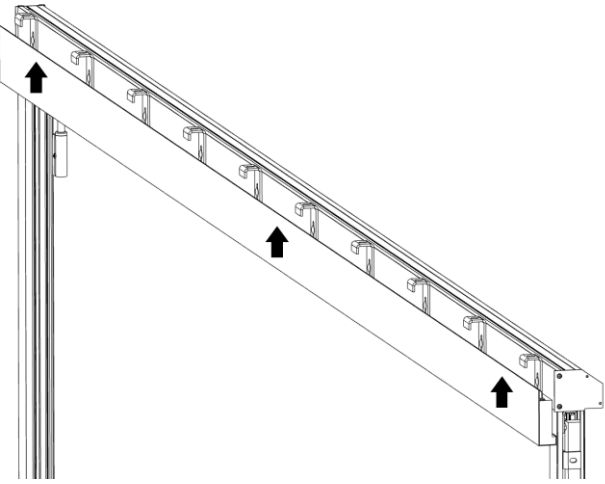

- Position the inner guide rail cover

4

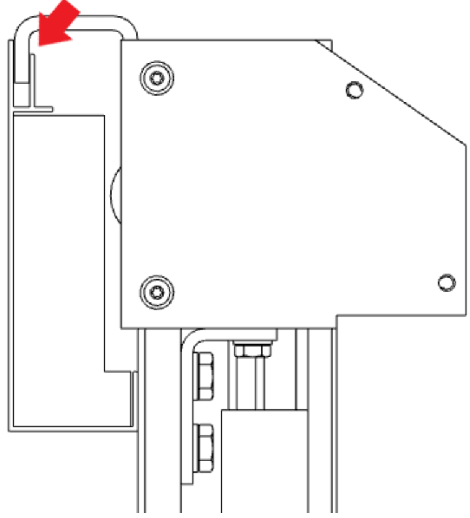

- Attention: position the cover using the mounting brackets

5

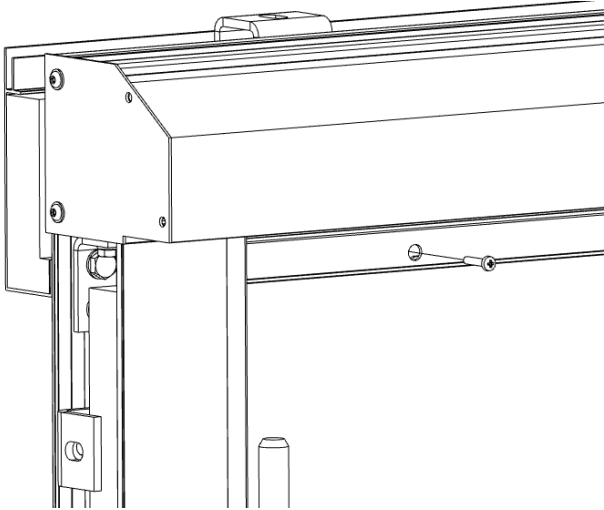

- Bolt the cover using the self-tapping screws and the factory-made holes in the guide rail

6

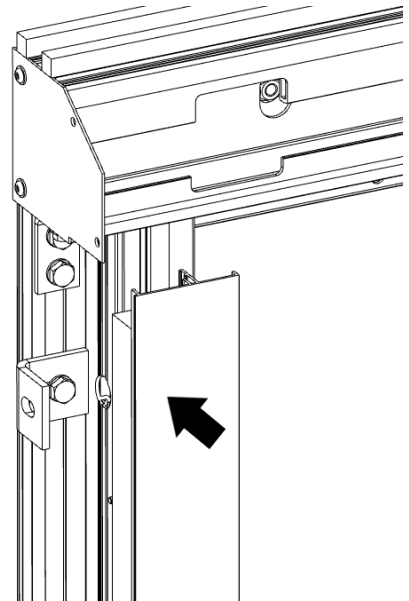

- Mount the compribands on the frame and the guide rail and position the cover on the frame profile

7

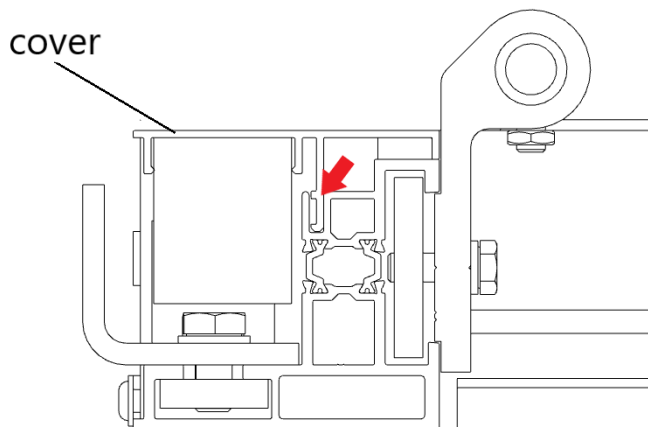

- Attention: position the cover correctly in the frame profile

8

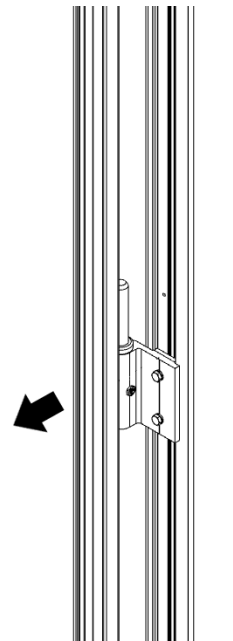

- Loosen the leaf seal in the area of approx. 85mm above each hinge flap of the frame profile

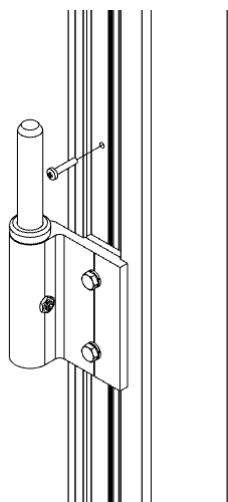
9

- Bolt the cover using a self-tapping screw and the factory-made holes and fix the leaf seal again

4.6.3 180° guide rail in front of/behind the soffit

1

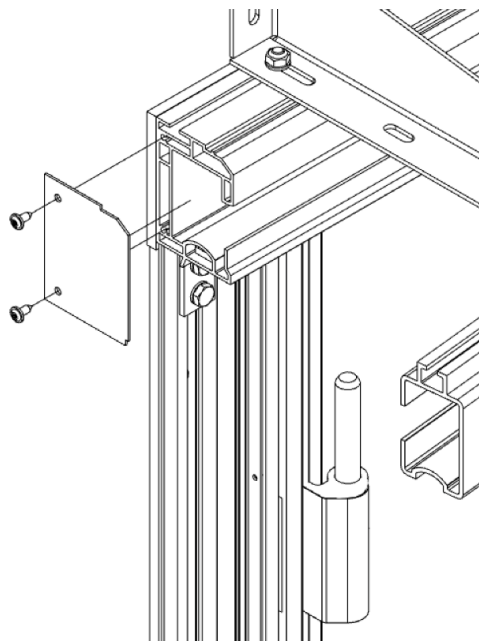

6,3 x 16

- Bolt the side guide rail cover on the left & right

2

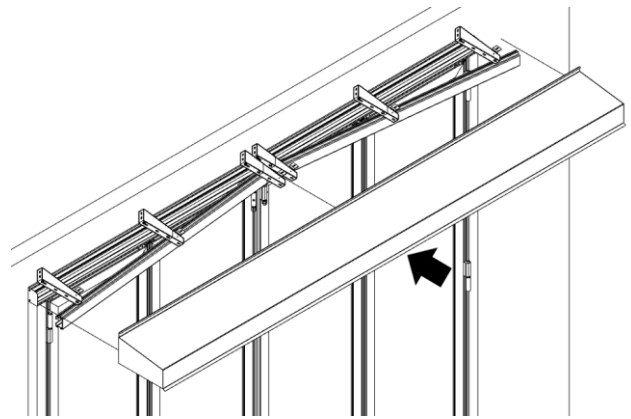

- Position the guide rail cover

3

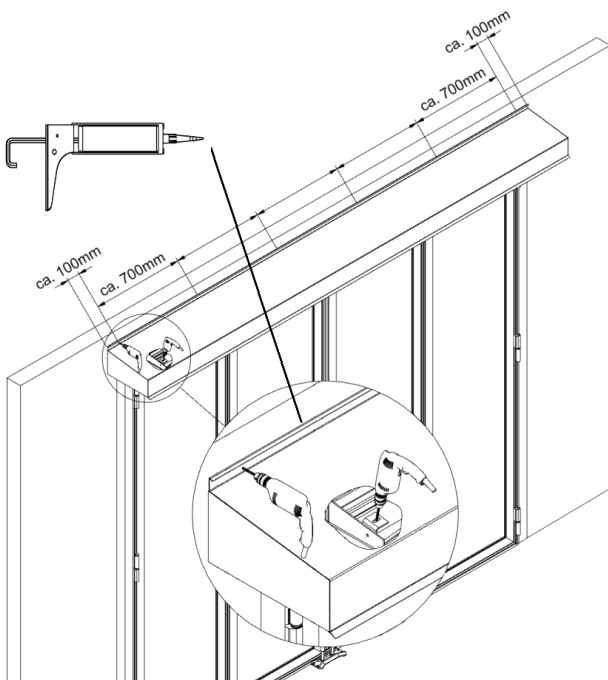

- Drill the guide rail cover approx. every 700mm / at the positions of the mounting frames and bolt or dowel to the masonry

4.6.4 180° guide rail corner soffit

1

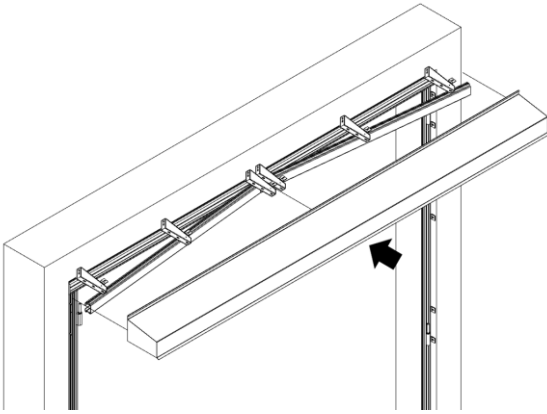

- Position the guide rail cover

2

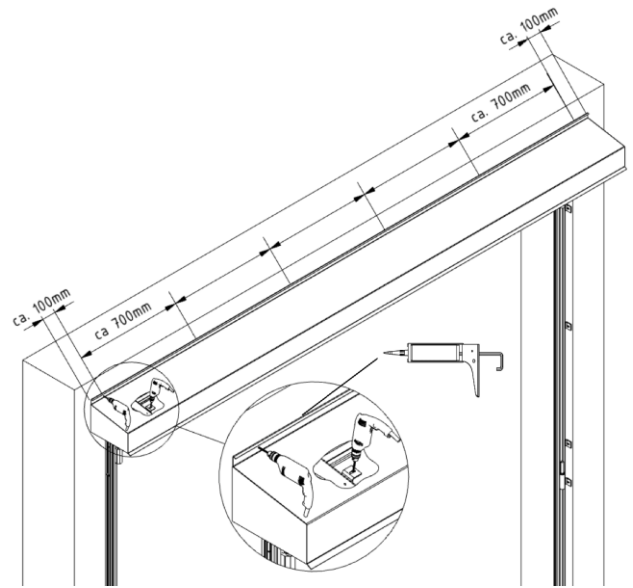

- Drill the guide rail cover approx. every 700mm / at the positions of the mounting frames and bolt or dowel to the masonry

4.7 Drive system installation

4.7.1 BASIC drive on the first leaf (opening inwards)

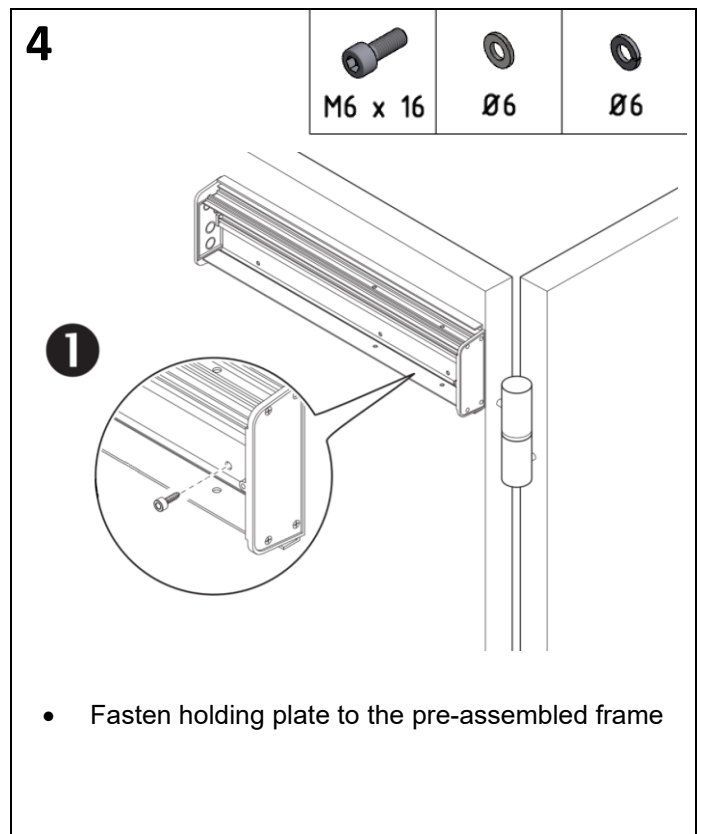
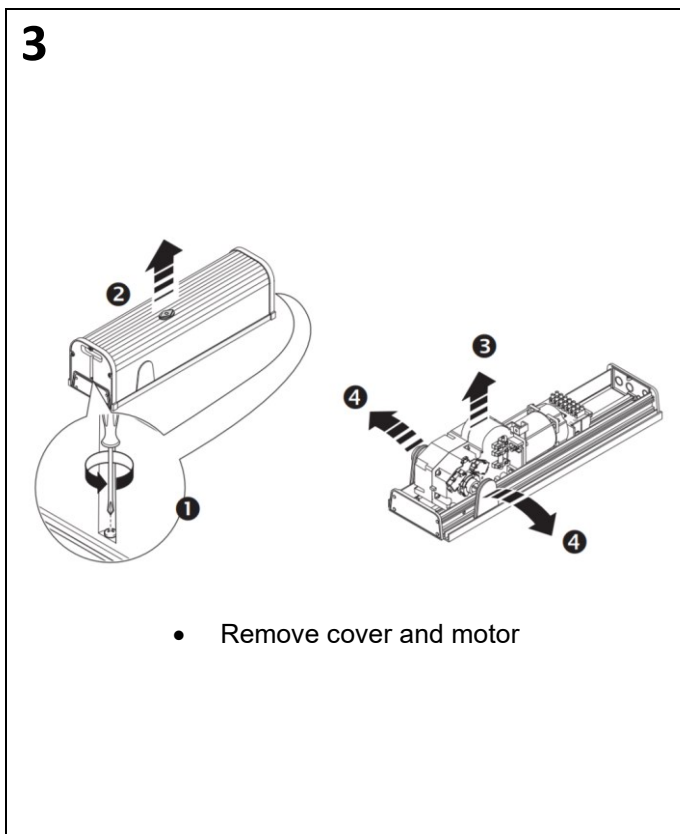
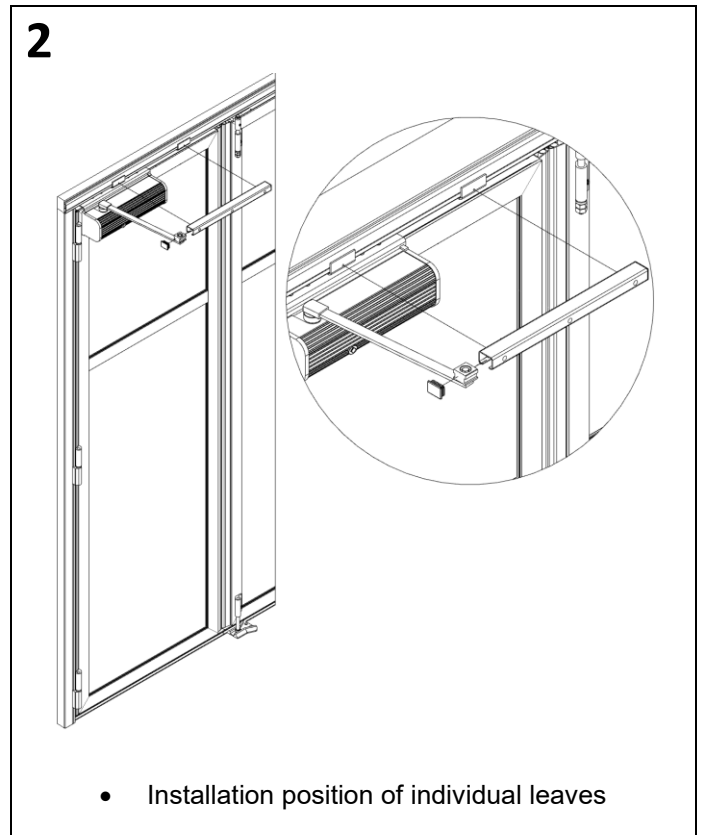
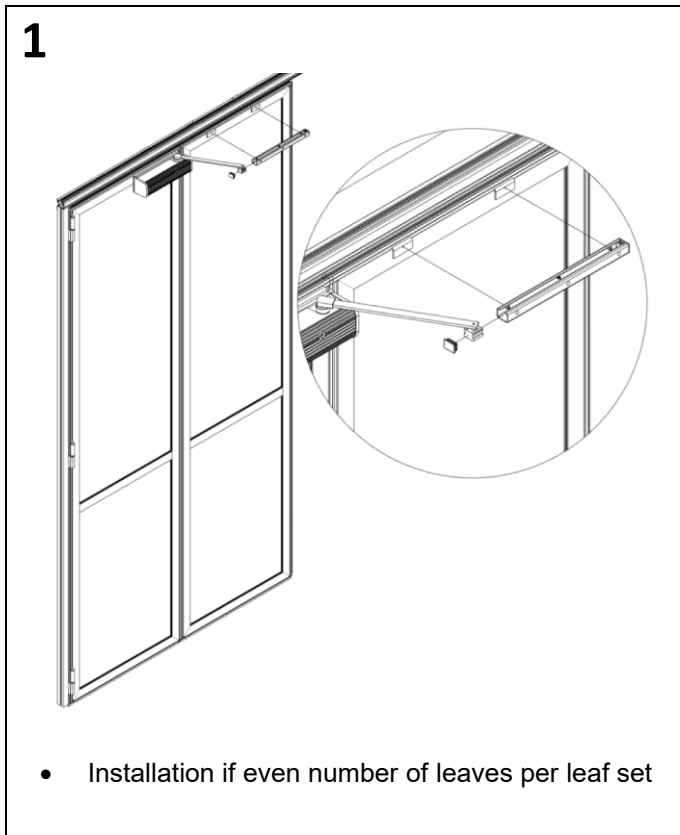

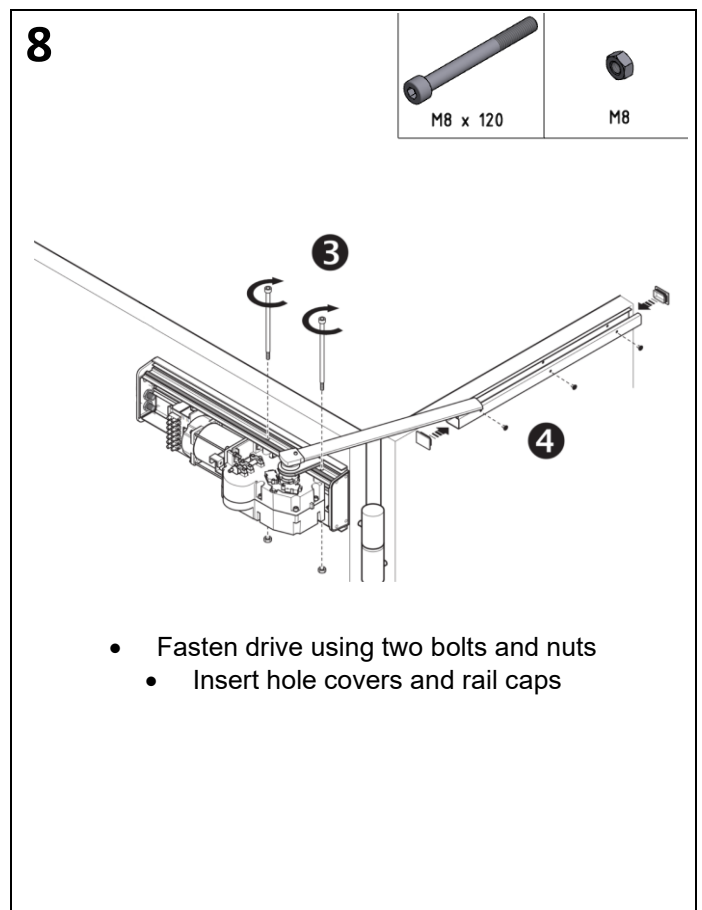
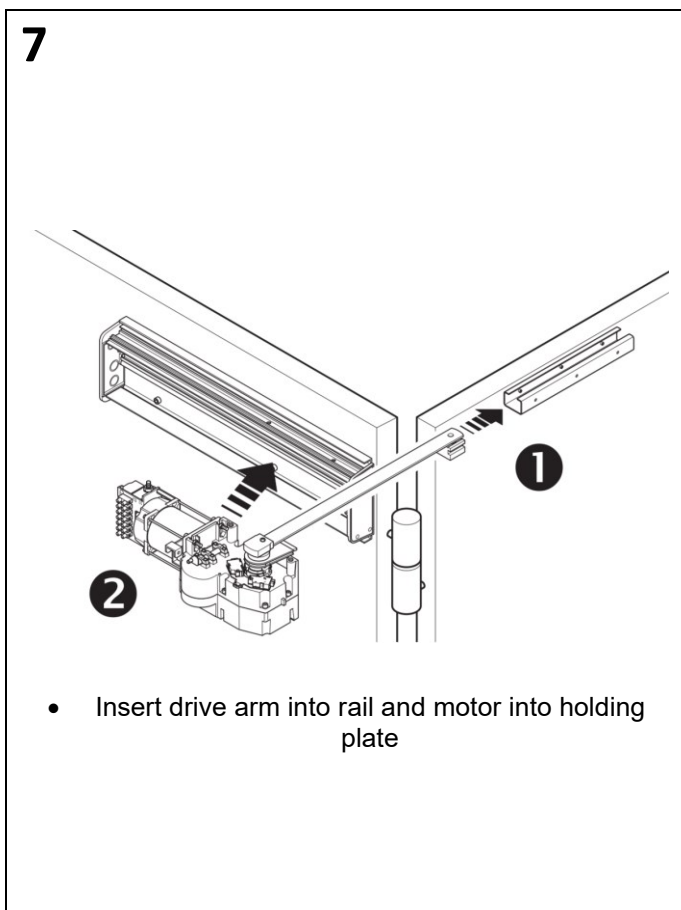
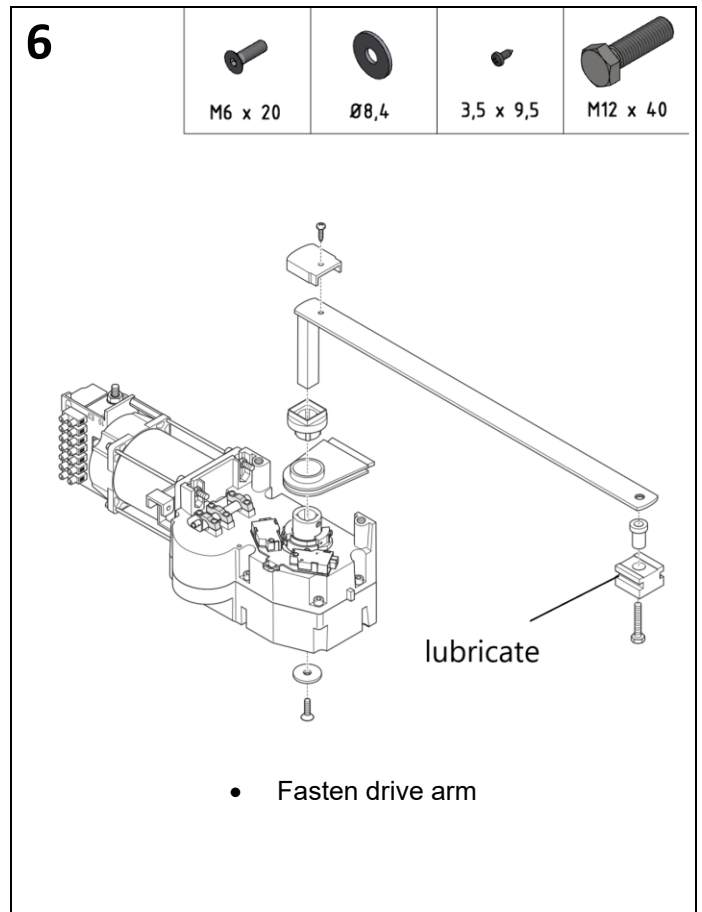
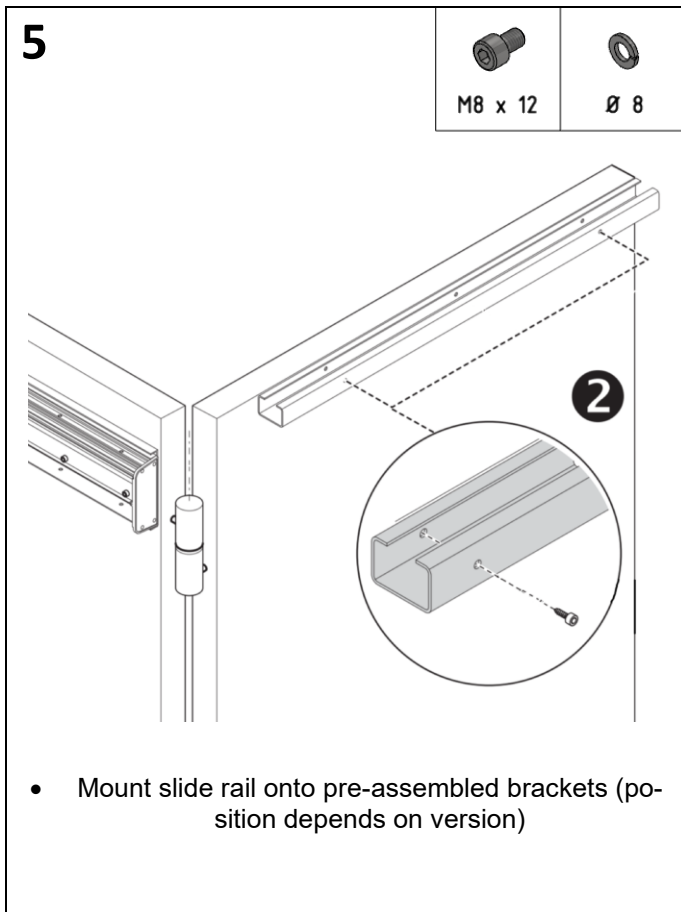

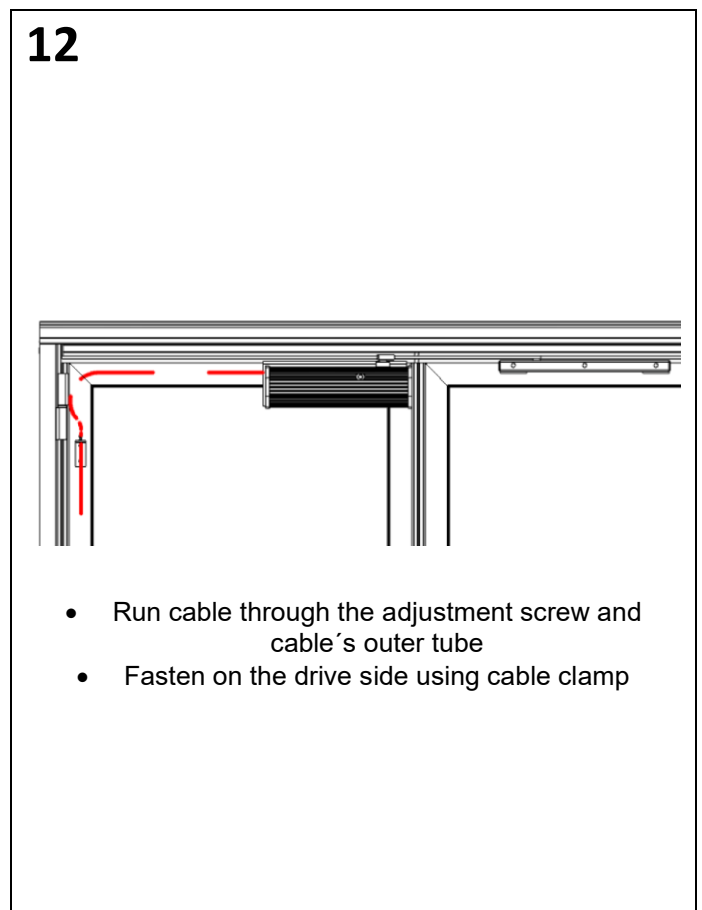
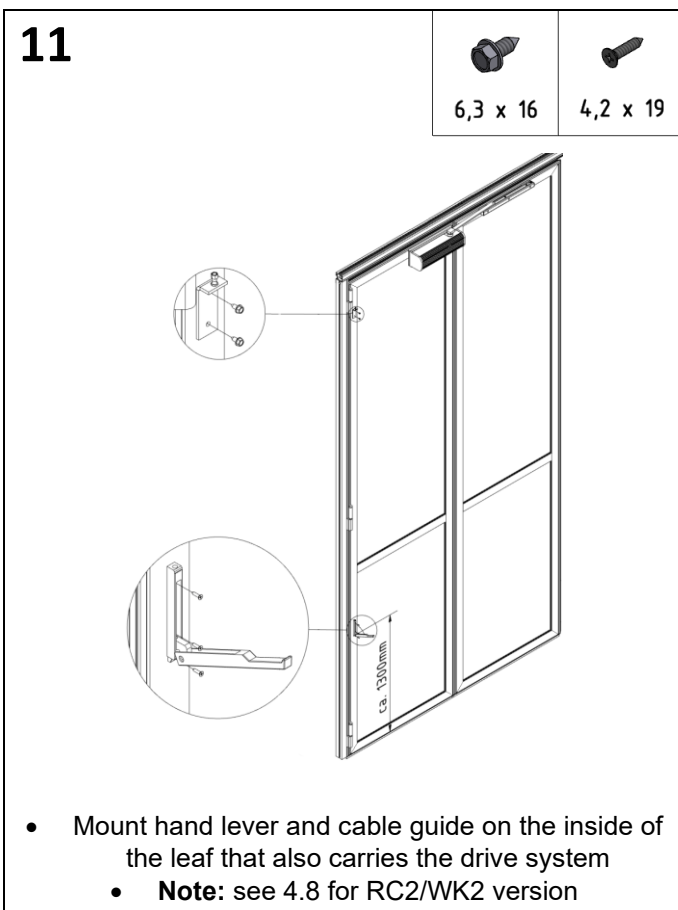
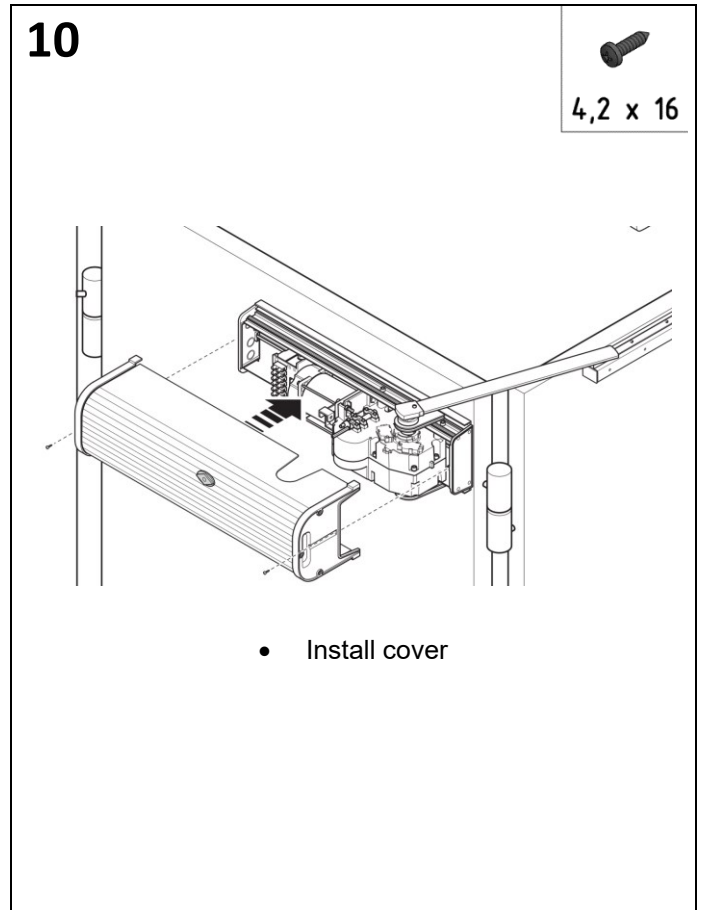
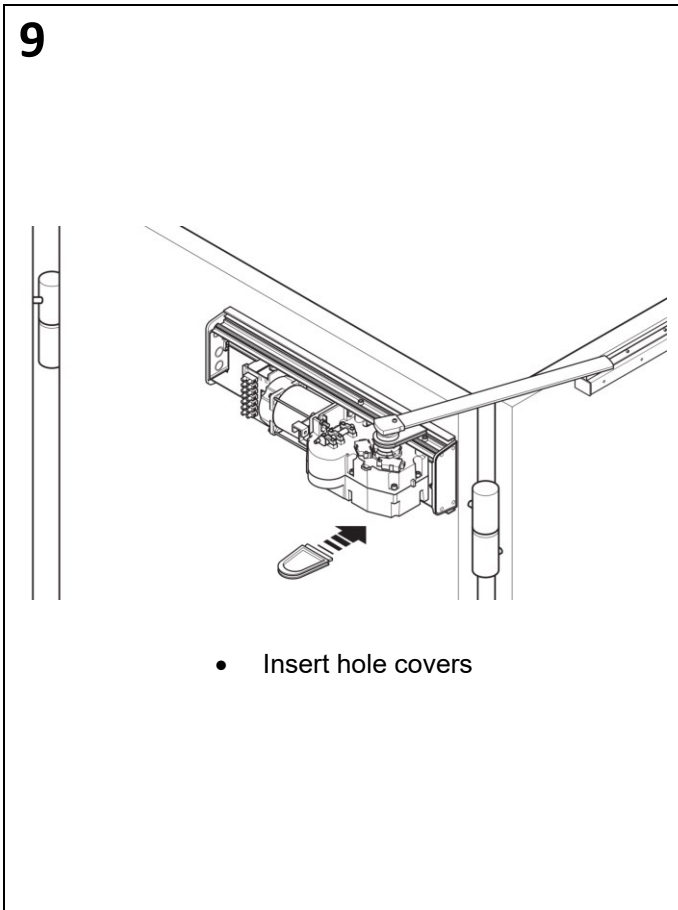

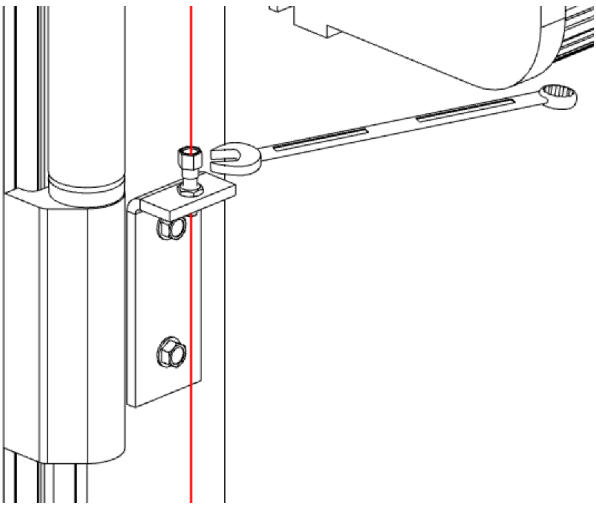
13

- Adjust cable tension by means of the adjusting screw in such a way that the lever is fully open when unlocked

4.7.2 BASIC drive on the second leaf (opening inwards)

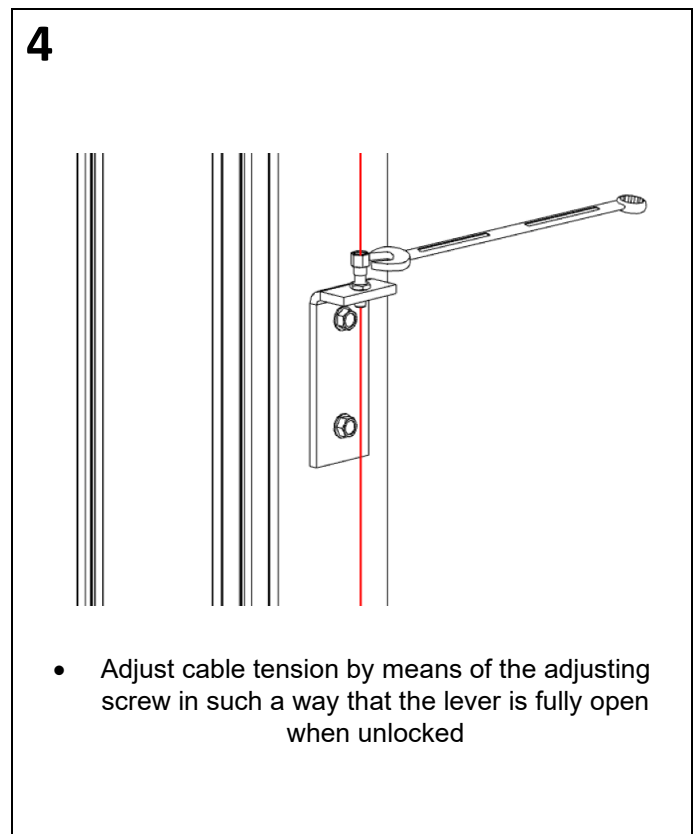
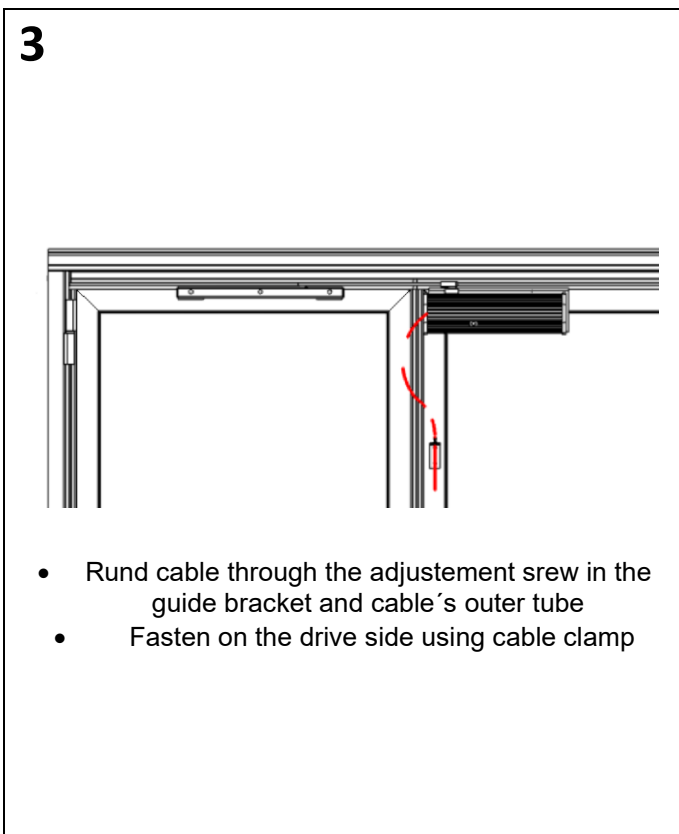
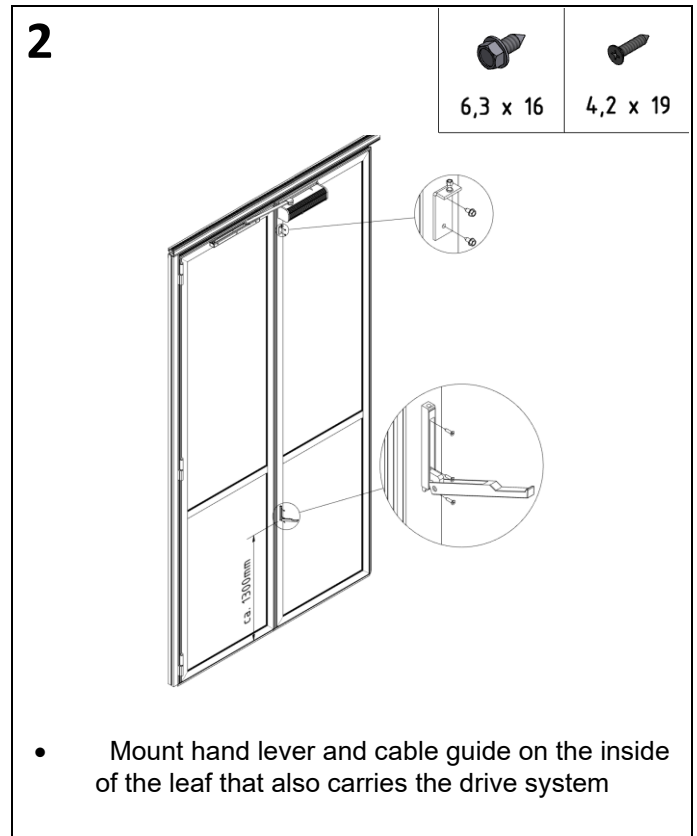
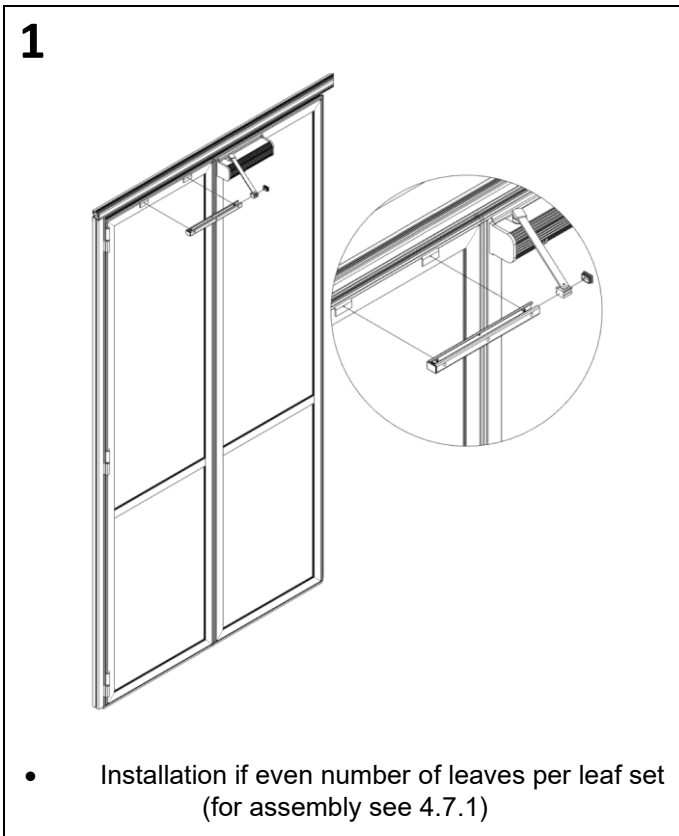

4.7.3 BASIC drive on the first leaf (opening outwards)

1

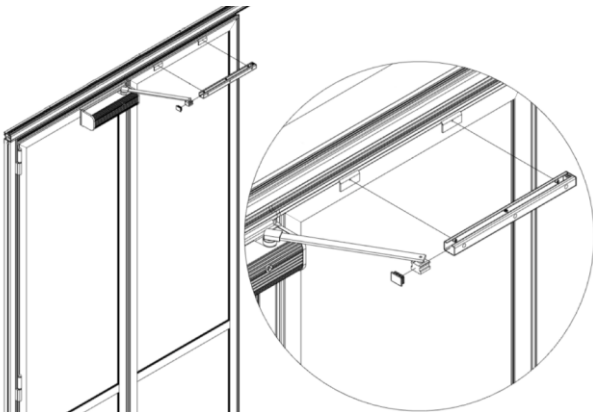

- Installation if even number of leaves per leaf set (for assembly see 4.7.1)

2

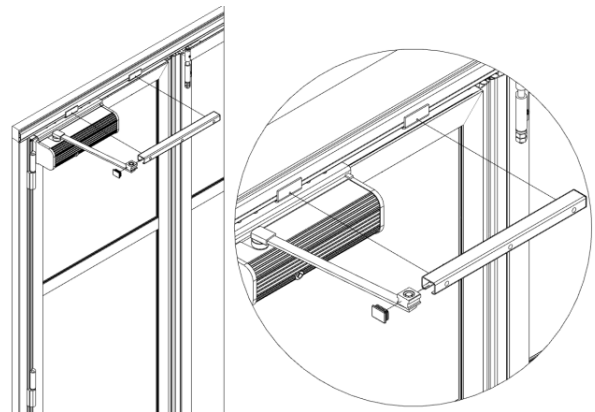

- Installation if uneven number of leaves per leaf set (for assembly see 4.7.1)

3

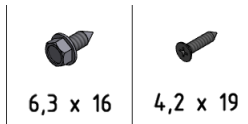
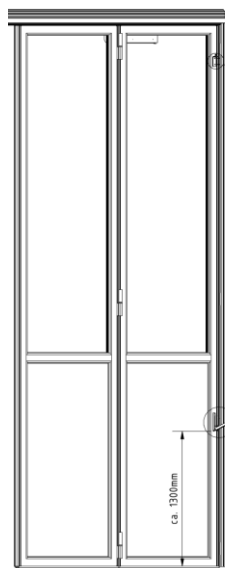

- Mount hand lever and cable guide on the frame or on the wall on the inside of the leaf

4



- Run cable through the adjustment screw in the guide bracket and cable's outer tube
- Run through the leaf and fasten on the drive side using cable clamp

5

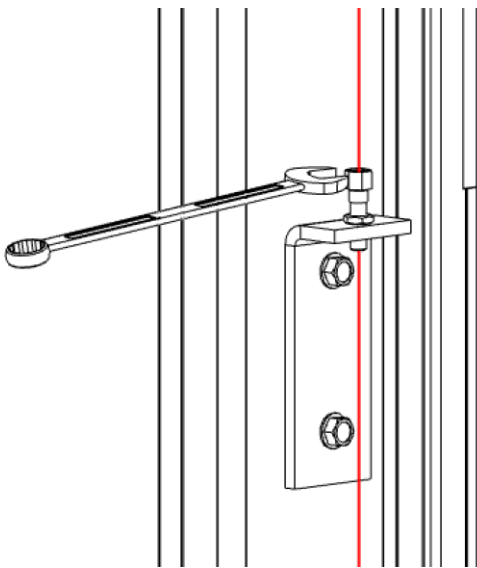

- Adjust cable tension by means of the adjusting screw in such a way that the lever is fully open when unlocked

6

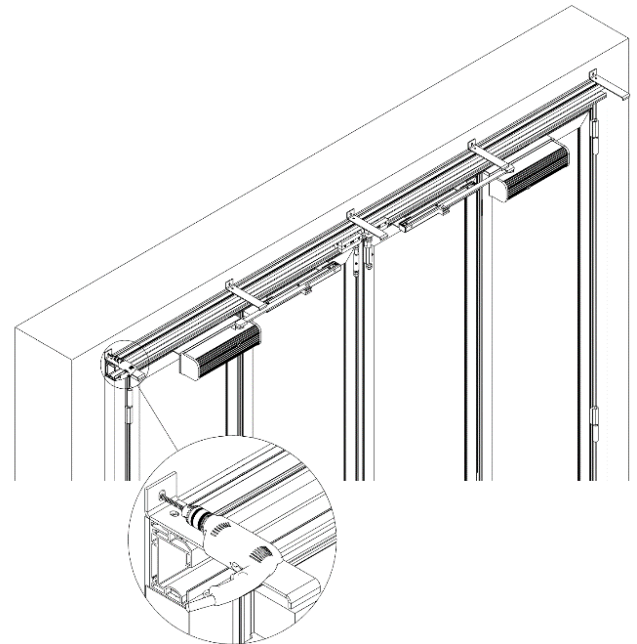

- Drill and bolt the brackets

7

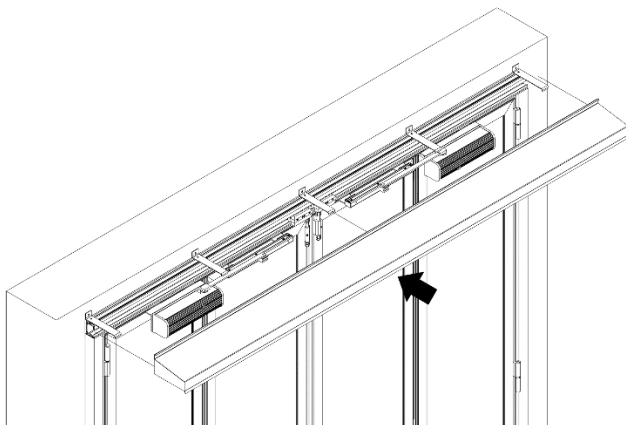

- Position the drive cover

8

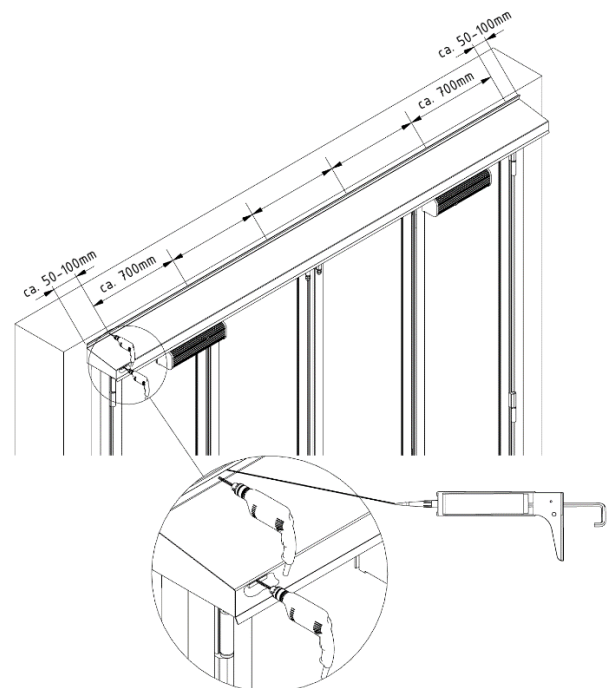

- Drill and bolt the drive cover approx. every 700mm and drill and rivet at every bracket

4.7.4 BASIC drive on the second leaf (opening outwards)

1

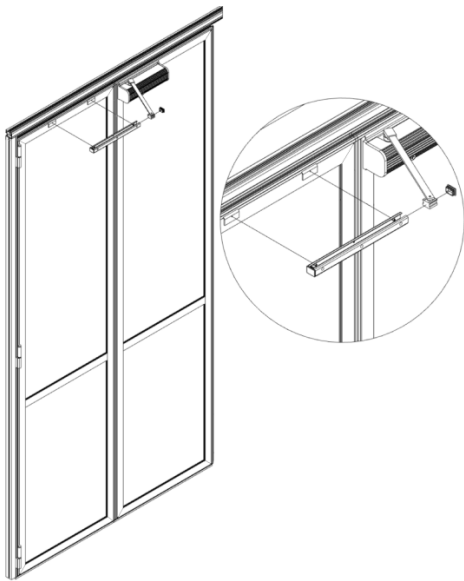

- Installation if even number of leaves per leaf set (for assembly see 4.7.1)
- Mount the hand lever and cable guide for 2 or 4 leaf sets according to 4.9

2

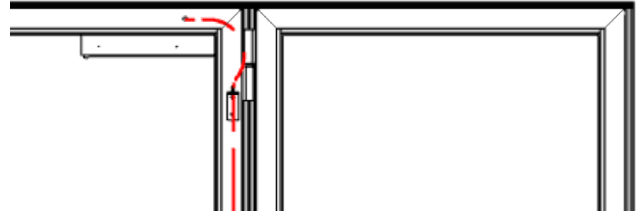

- Run cable through the adjustment screw in the guide bracket and cable's outer tube
- Run through the leaf and fasten on the drive side using cable clamp

3

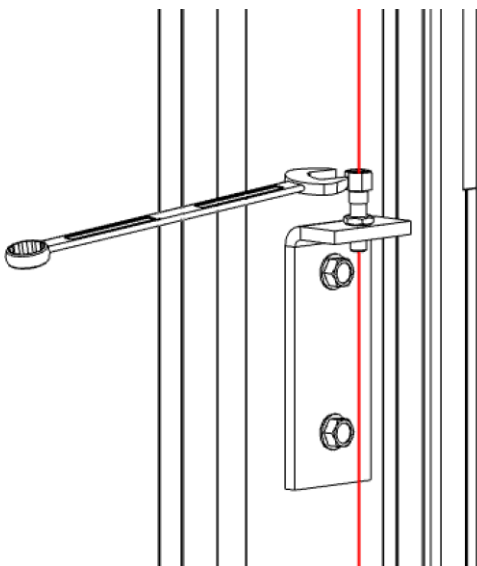

- Adjust cable tension by means of the adjusting screw in such a way that the lever is fully open when unlocked

4

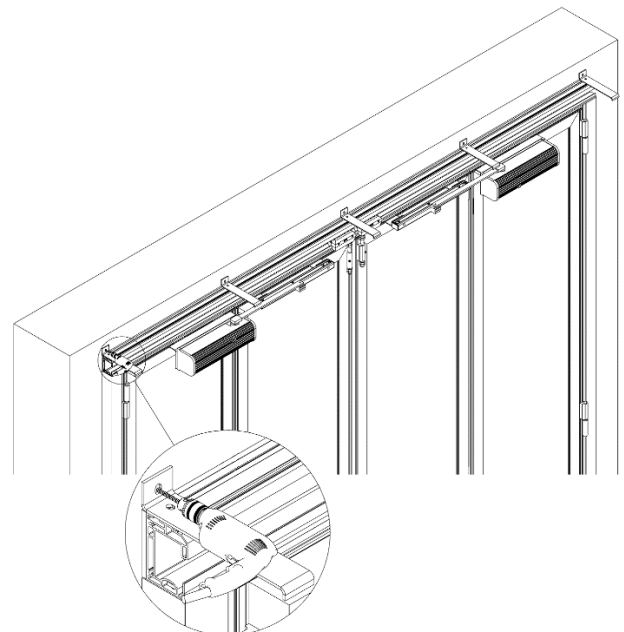

- Drill and bolt the brackets

5

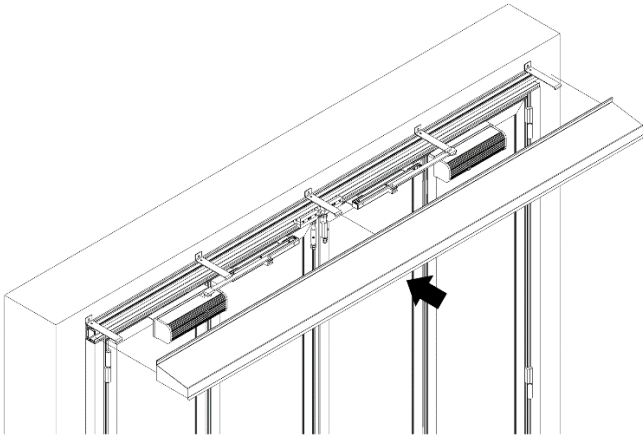

- Position the drive cover

6

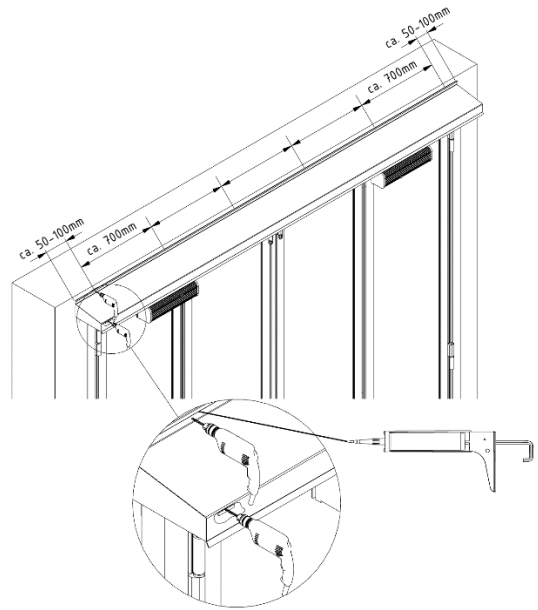

- Drill and bolt the drive cover approx. every 700mm and drill and rivet at every bracket

7

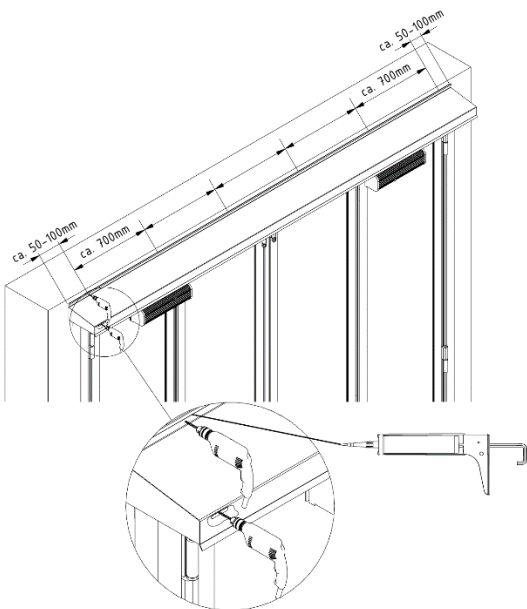

- Drill and bolt the drive cover approx. every 700mm and drill and rivet at every bracket

4.7.5 BASIC drive, internal (opening outwards)

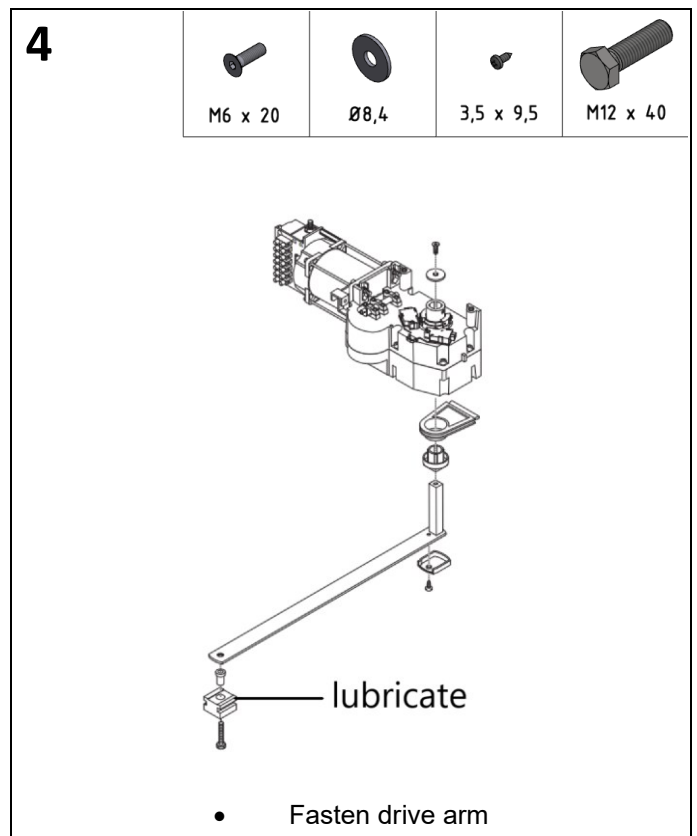
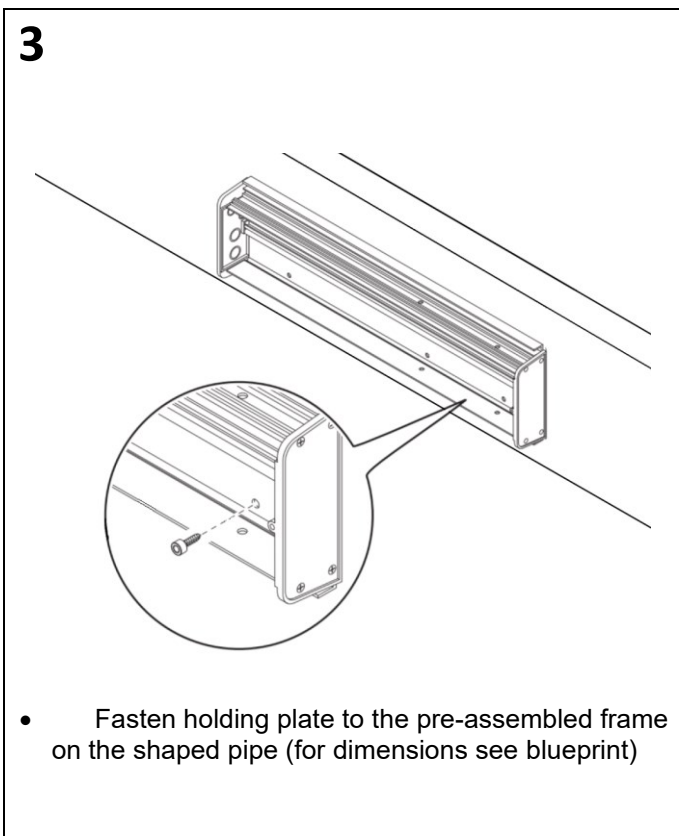
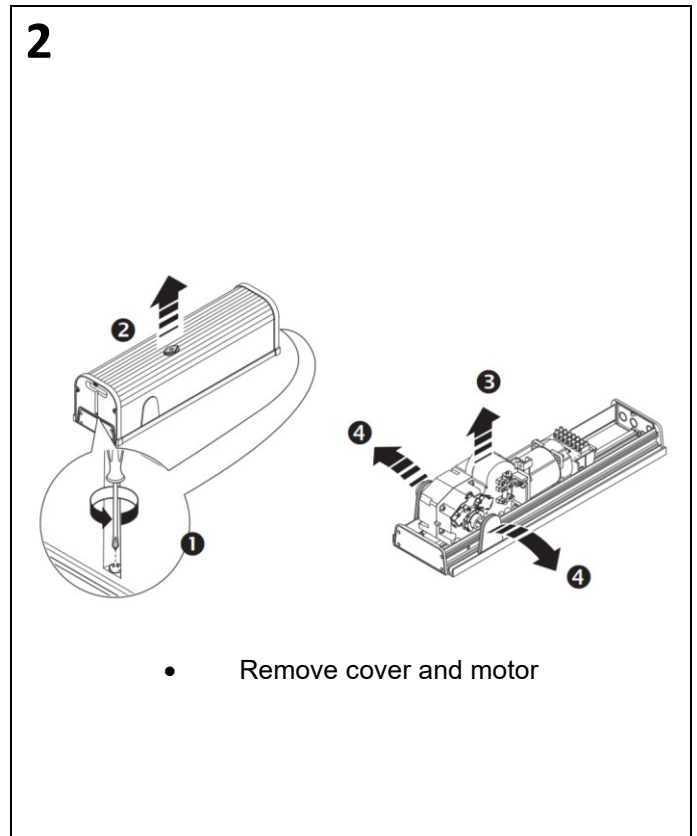
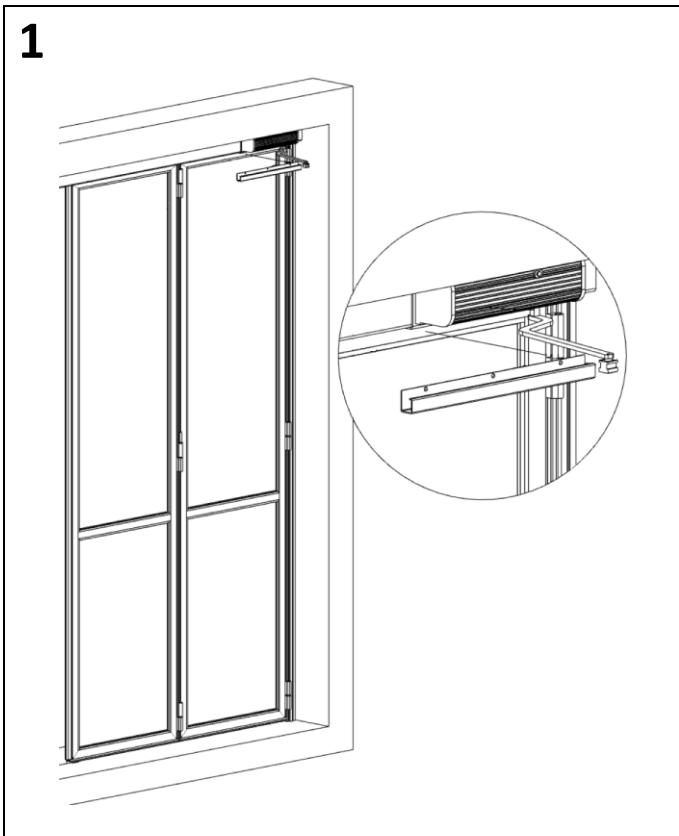

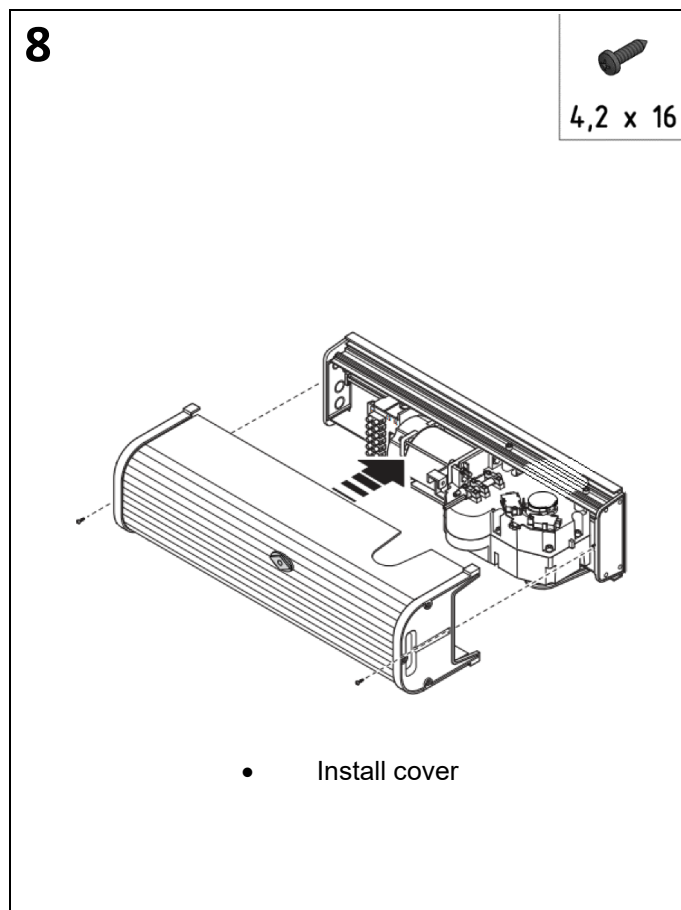
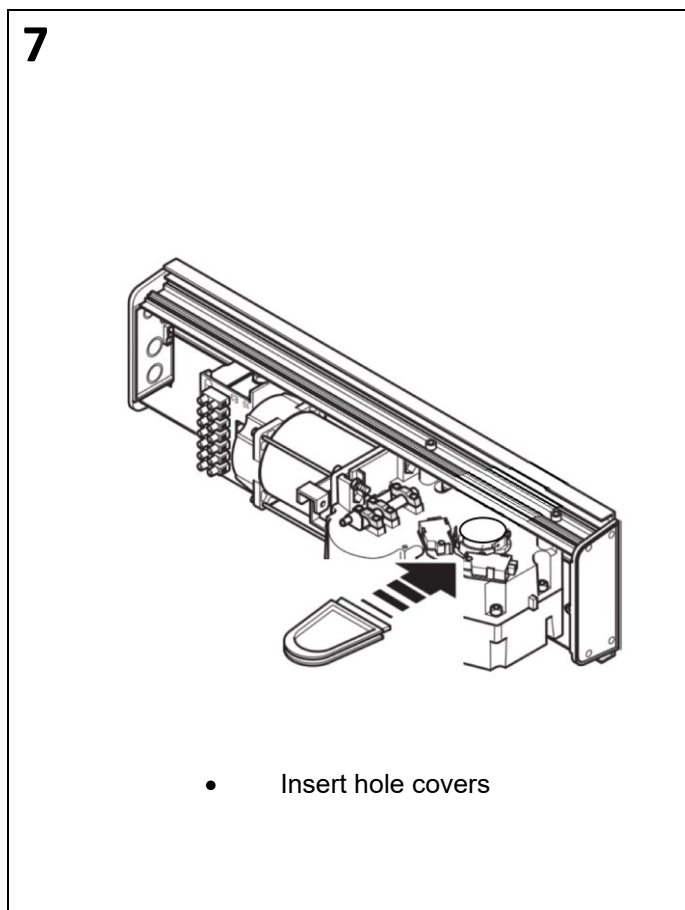
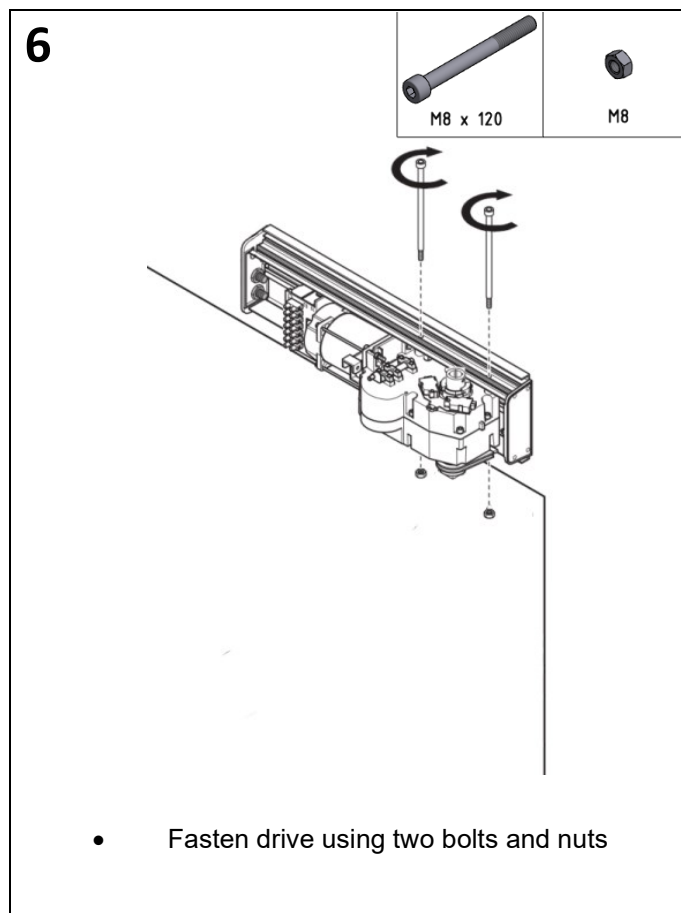
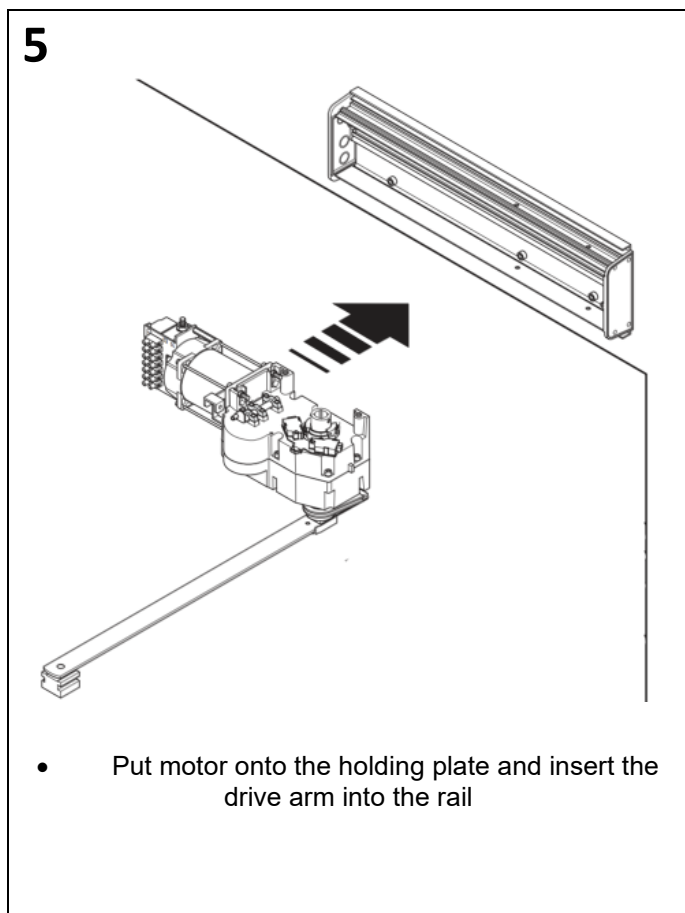

9

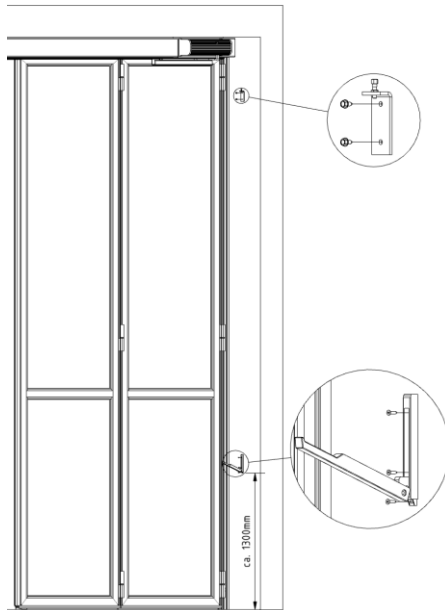
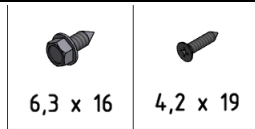

- Install hand lever and cable guide on the side of the door
- **Note:** see 4.8 for RC2/WK2 version

10

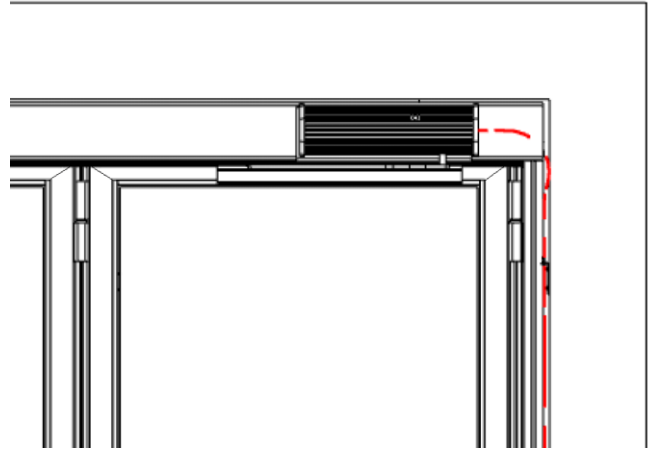

- Run cable through the adjustment screw in the guide bracket and cable's outer tube
- Fasten on the drive side using cable clamp

11

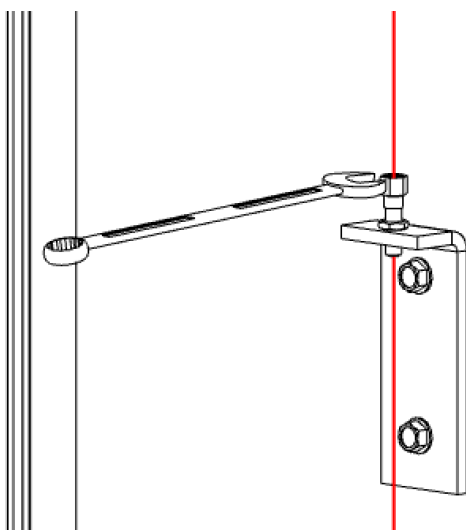

- Adjust cable tension by means of the adjusting screw in such a way that the lever is fully open when unlocked

4.7.6 POWER drive

1

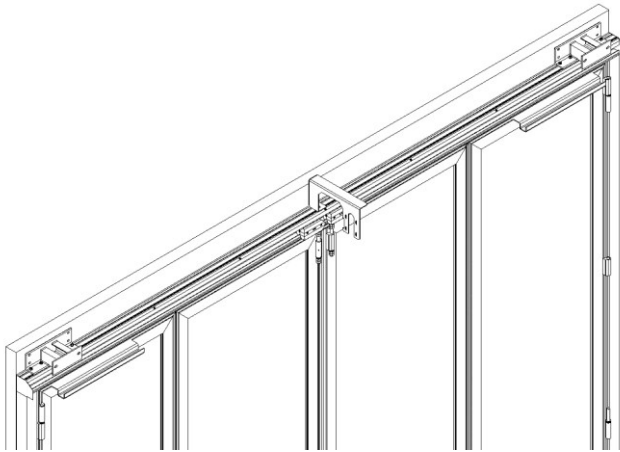

- Gearbox and drive frame as well as guide rails installed from the factory

2

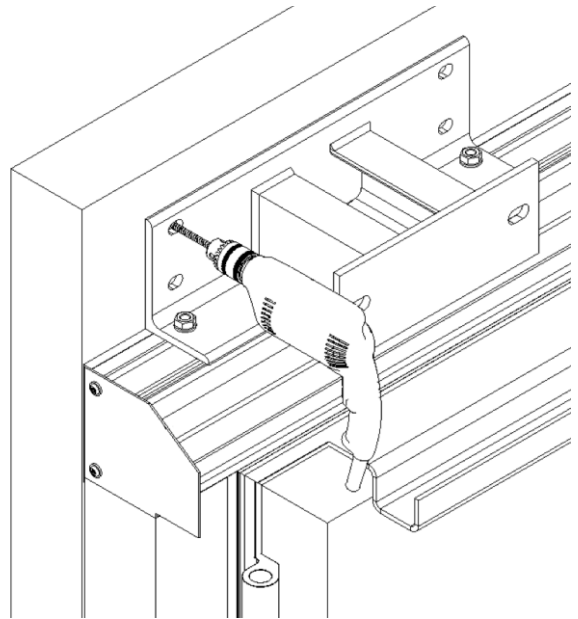

- Drill and bolt gearbox and drive frame at the 4 or 2 holes

3

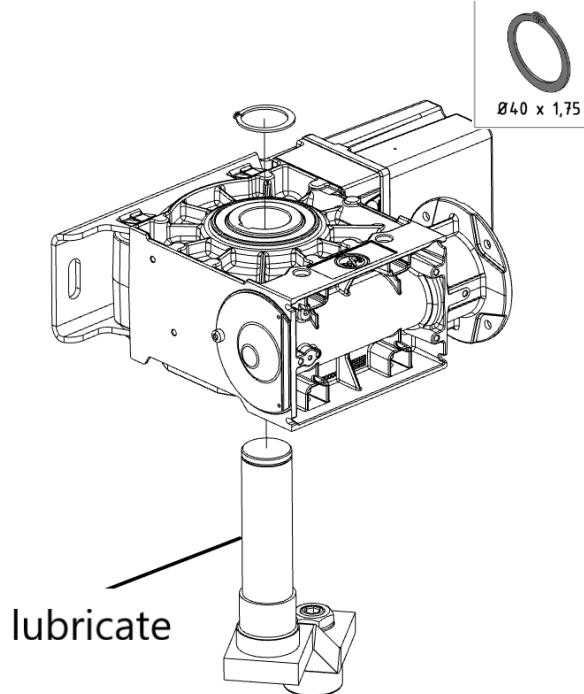

- Insert drive arm into the left side gearbox and fasten using retaining clip

4

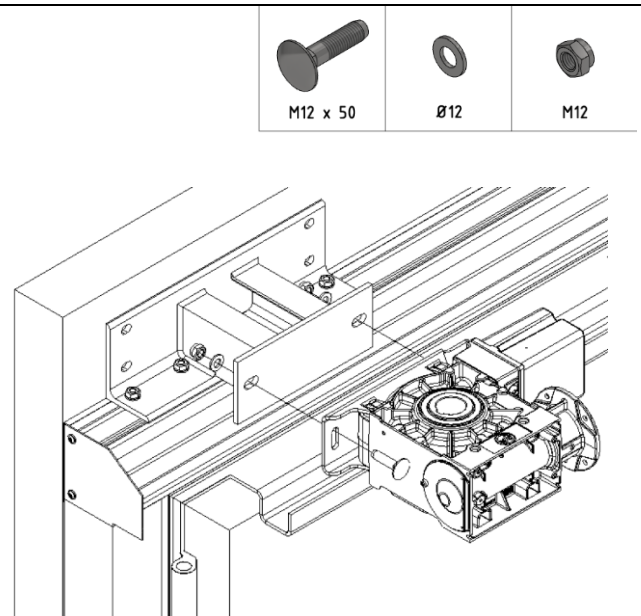

- Fasten left gearbox
- Insert the drive arm into the guide rail

5

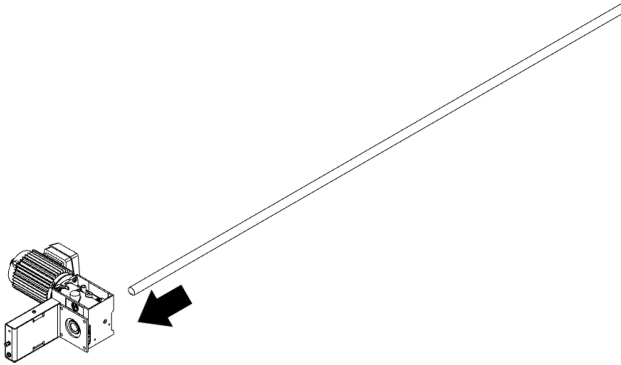

- Slide drive shaft through the drive motor with pre-assembled emergency release frame

6

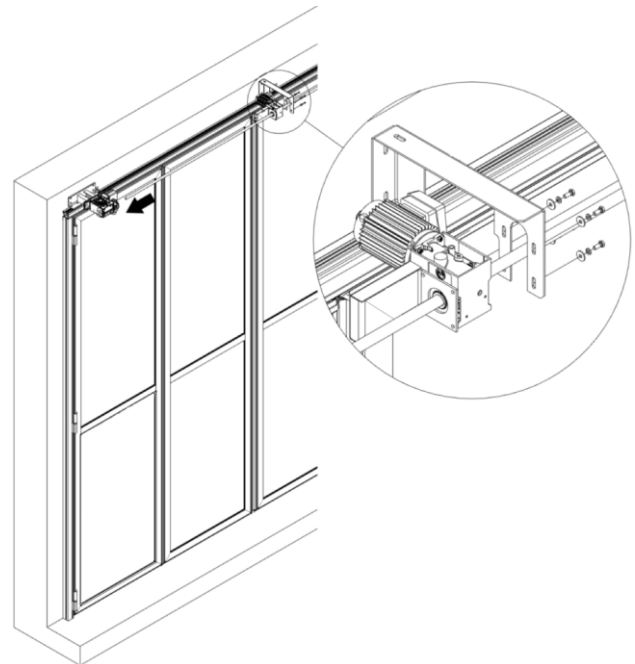
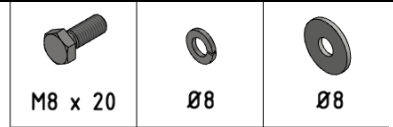

- Insert drive shaft into the left side gearbox and fasten motor to the drive system frame

7

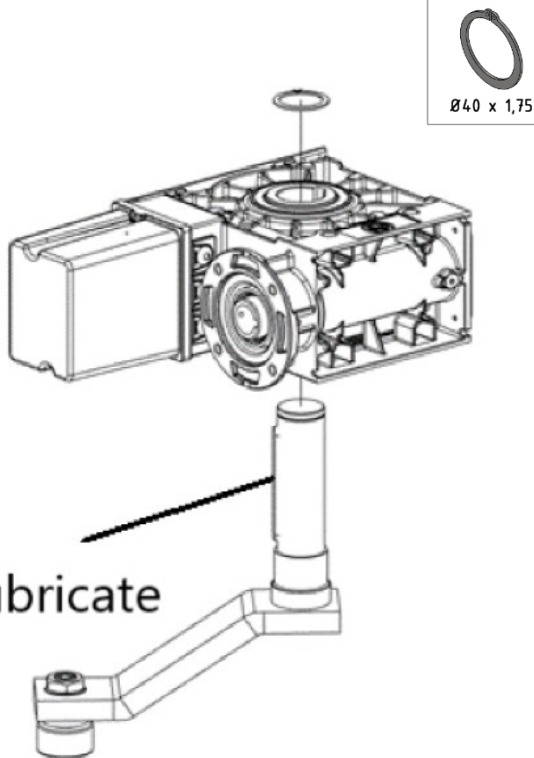

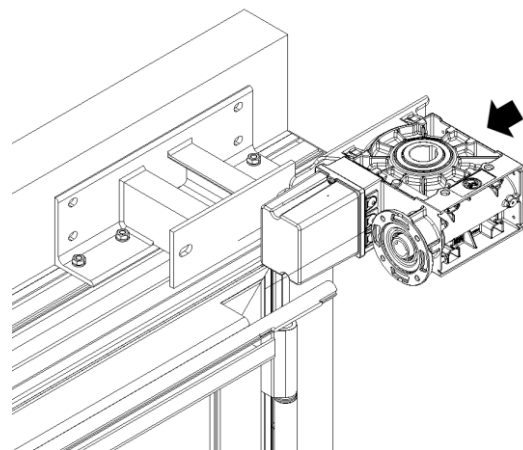

- Insert drive arm into the right side gearbox and fasten using retaining clip and key

8



- Put on the right side gearbox
- Insert the drive arm into the guide rail

9

		
M12 x 50	Ø12	M12

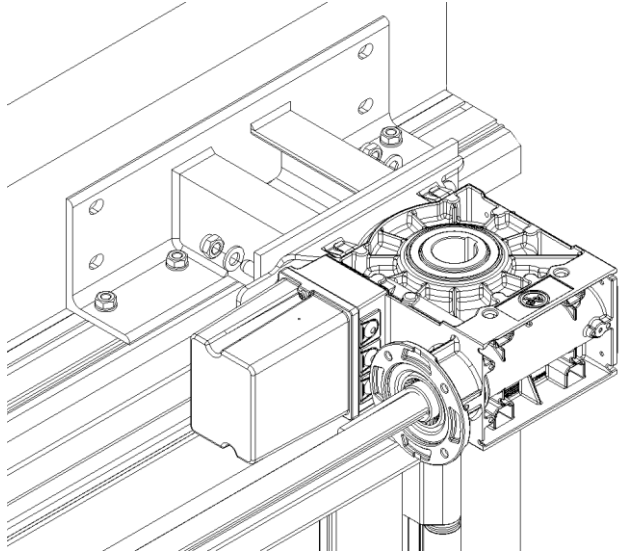

- Bolt the right side gearbox

10

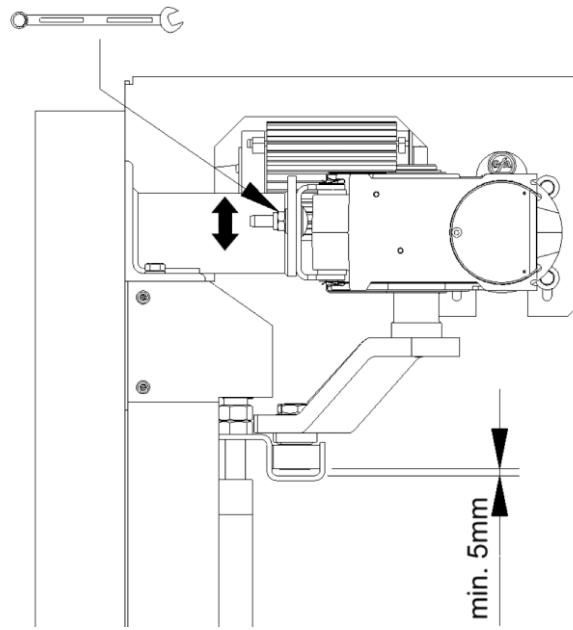

min. 5mm

- Adjust gap between guide rail and track roller

11

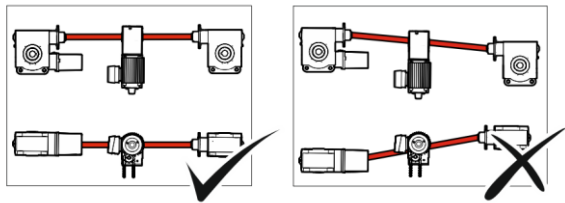

- Align drive system and gearbox flush

12

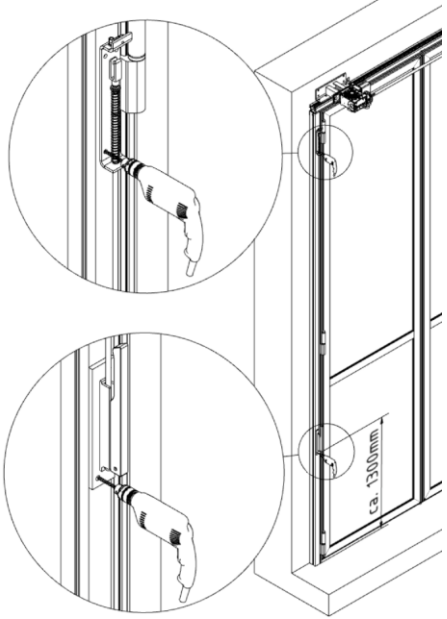

- Hand lever, linkage and transfer frame are pre-installed from the factory
- Drill and bolt the unit onto the door frame or on the side of the door
- **Note:** see 4.8 for RC2/WK2 version

13

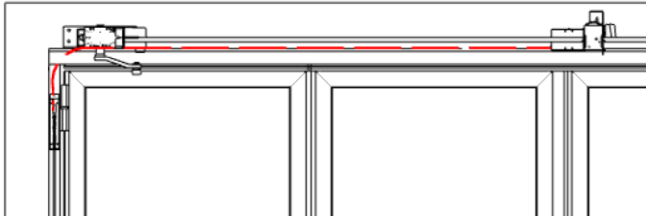

- Run a wire cable from the emergency release frame to the transfer frame

14

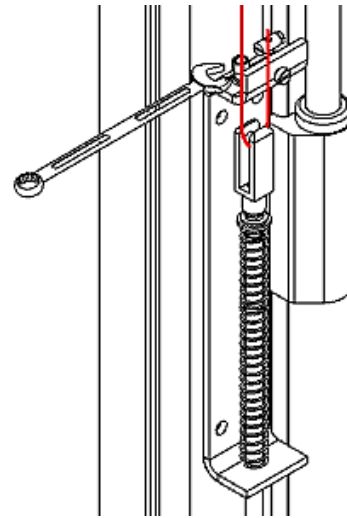

- Cut the cable to the correct length (fully opened lever and unlocked motor) and secure
- Adjust cable tension by means of the adjusting screw in such a way that the lever is fully open when unlocked

15

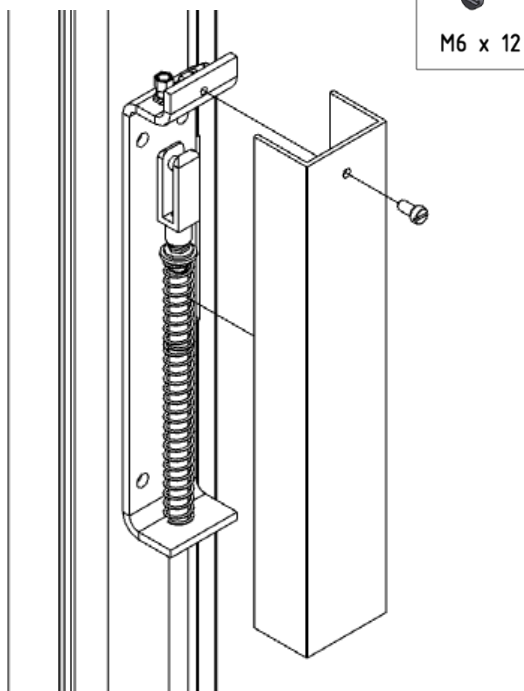

- Install cover

16

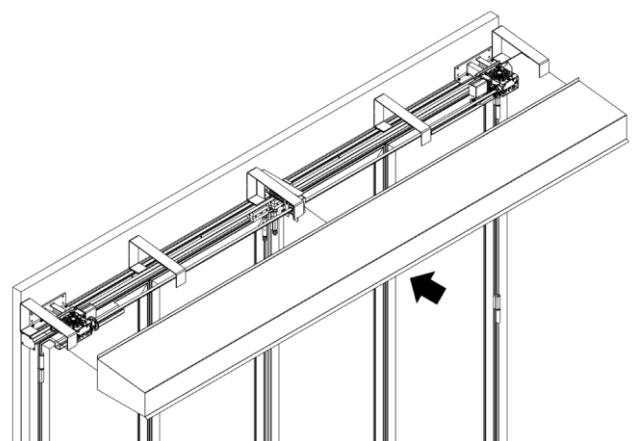

- Position the guide rail cover

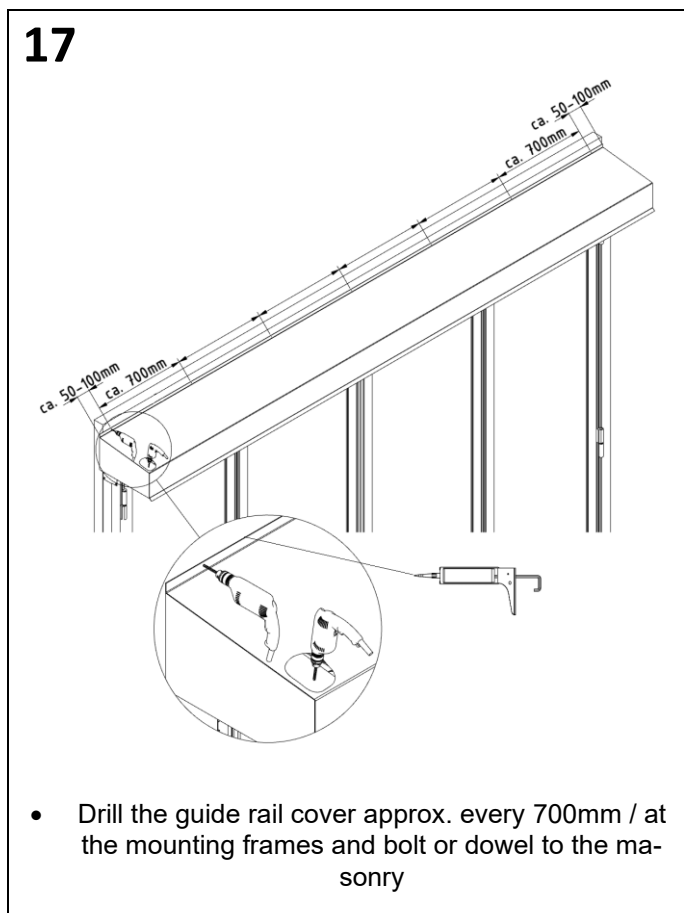

4.7.7 POWER drive, internal (opening outwards)

1

see blueprints

see blueprints

- Fasten rotating unit incl. rotating disc on the masonry according to blueprints
- Important: Note the markings on the left and right (seen from the side of the drive)



2

- Drill and bolt rotating unit using mounting bracket

3

- Bolt rotating unit to the lintel using the 4 holes

4

 M8 x 20	 Ø8
--	---

- Connect the pre-assembled leaf frame with the rotating unit

5

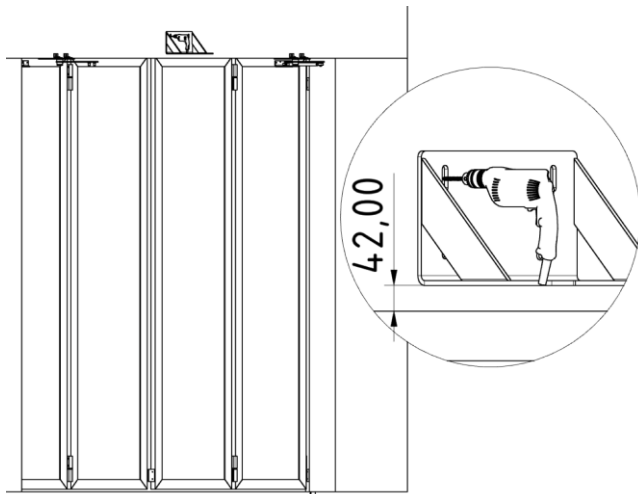

- Install motor frame in the centre of the door

6

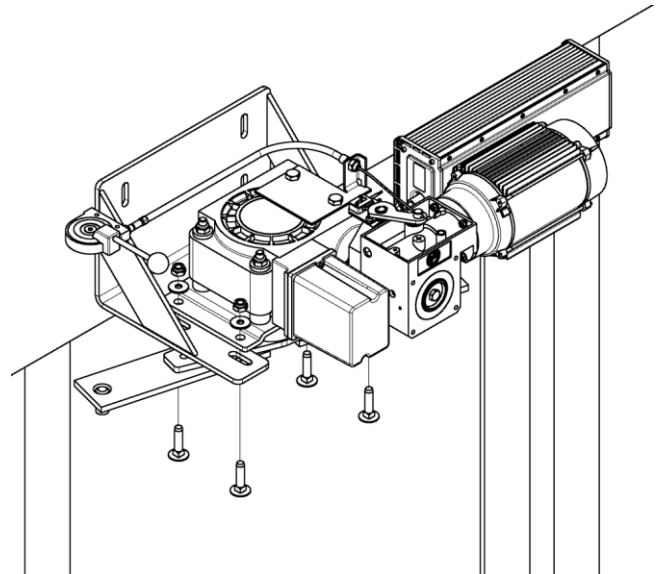
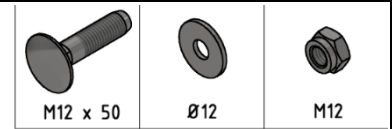

- Bolt drive unit to motor frame

7

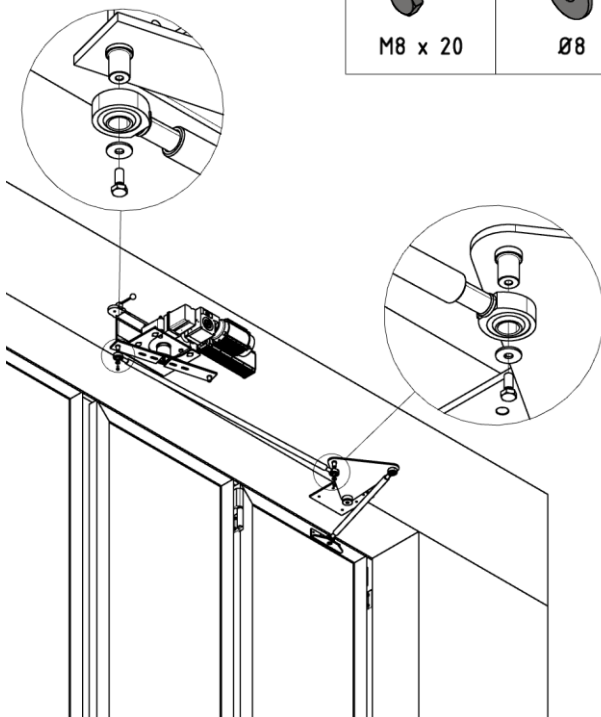
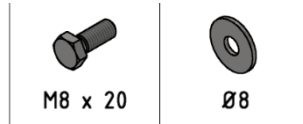

- Connect drive unit with rotating disc

8

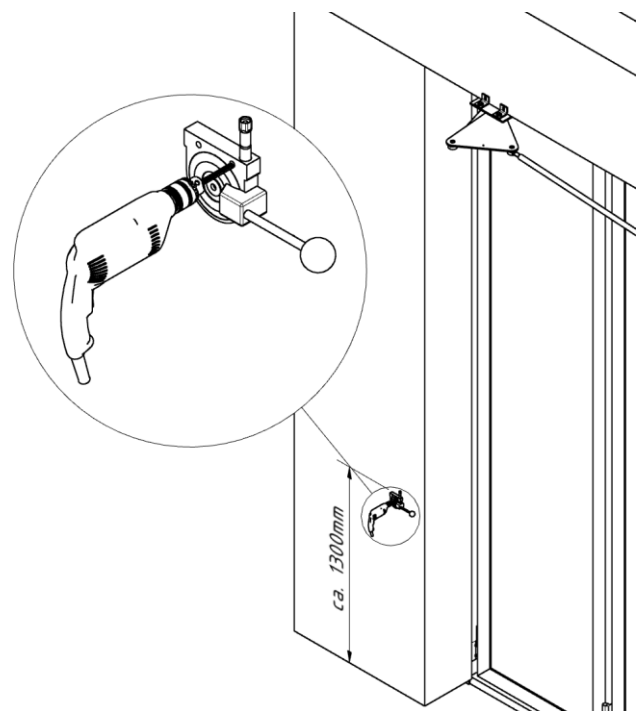

- Install hand lever on the side of the door
- **Note:** see 4.8 for RC2/WK2 version

9

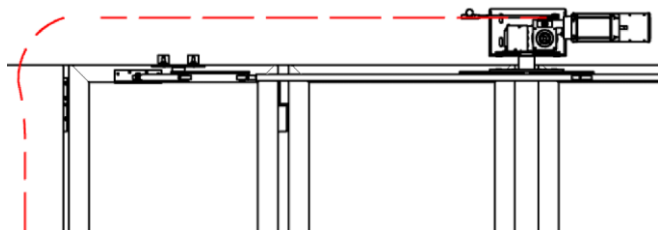

- Insert cable into cable's outer tube and fasten to hand lever

4.8 Additional hinge for RC2/WK2 version

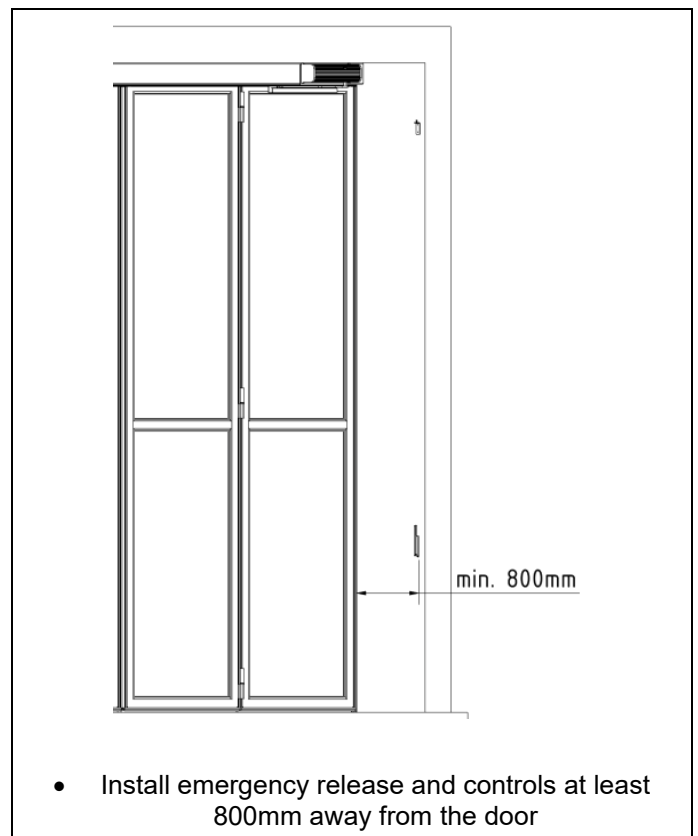
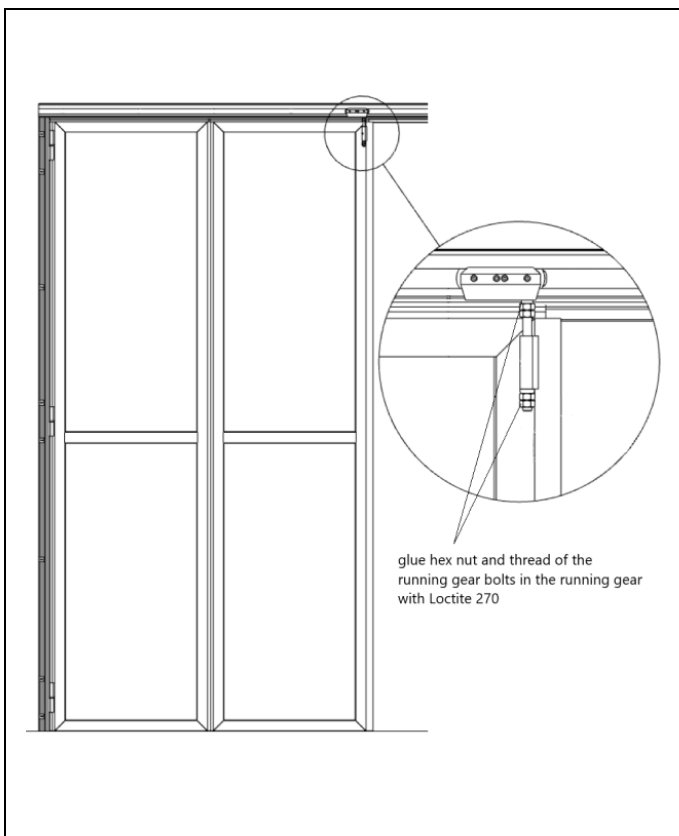
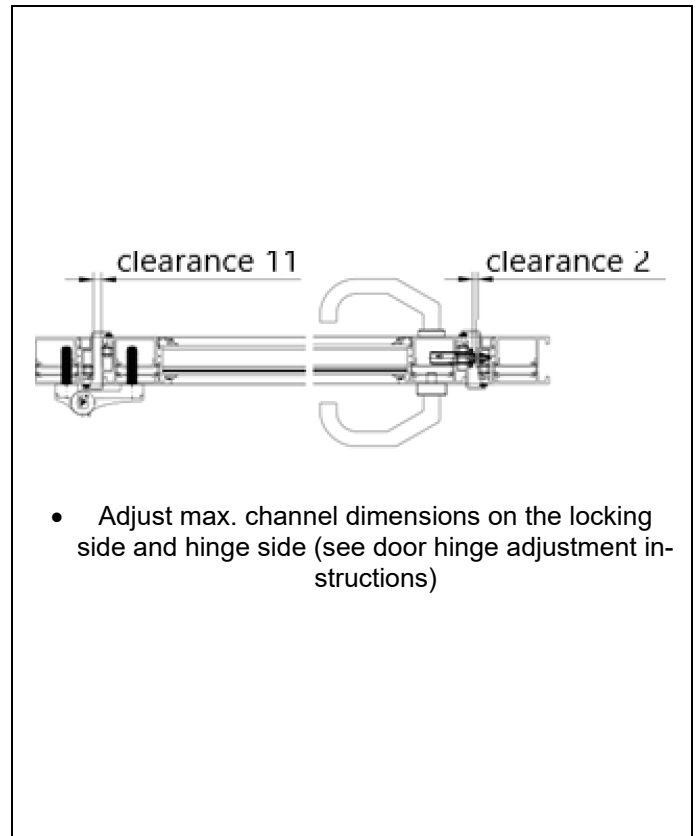
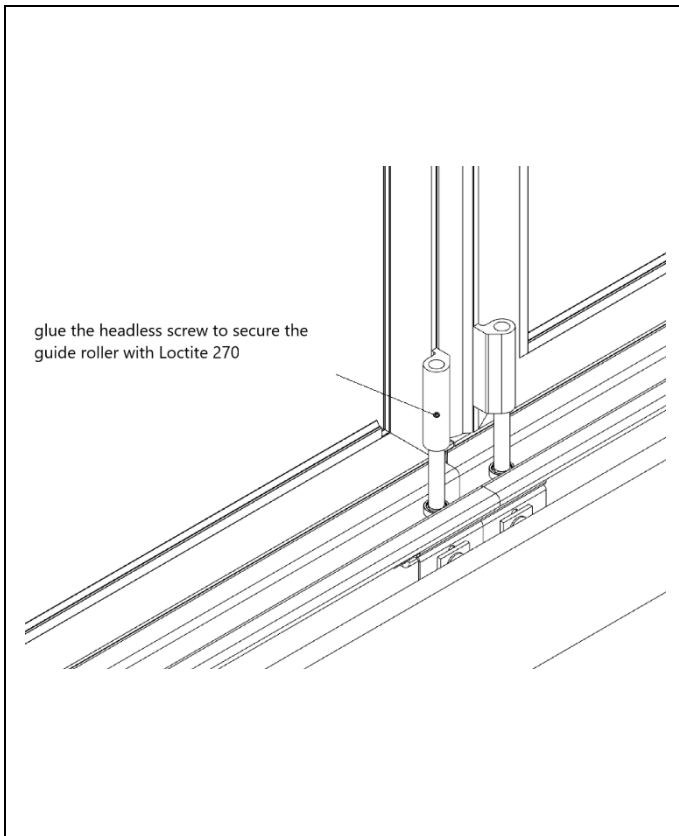

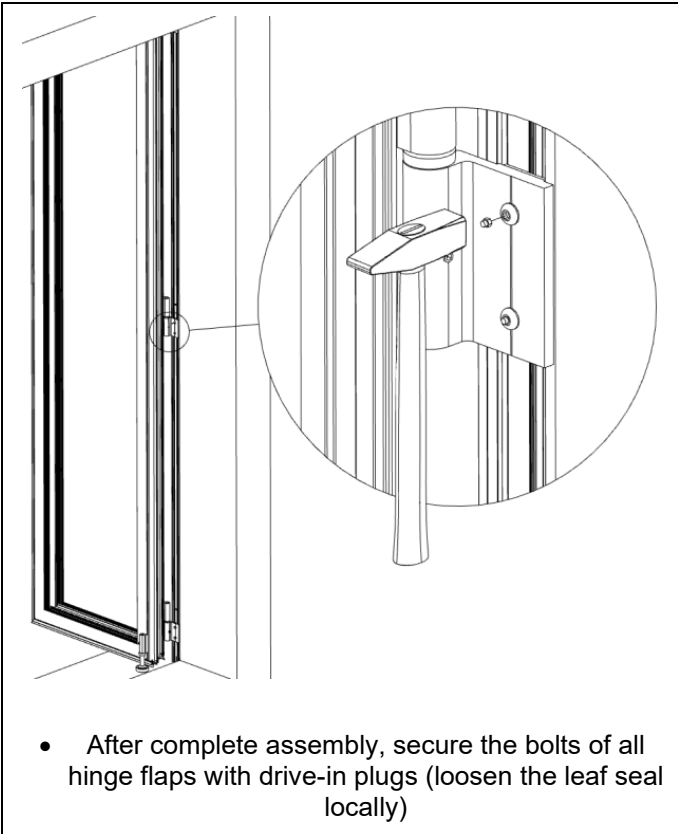

4.9 Additional hinge for installation of emergency release

4-leaf set folding door 4+4, opening outwards
 Ordered Height 2000-3199mm and Ordered Height >3750mm

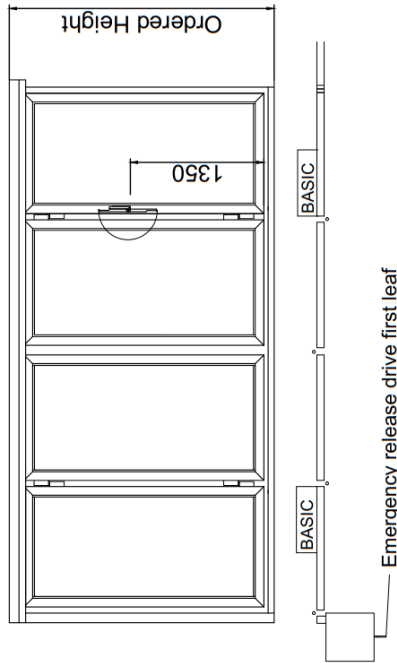

4-leaf set folding door 4+4, opening outwards
 Ordered Height 3200-3749mm

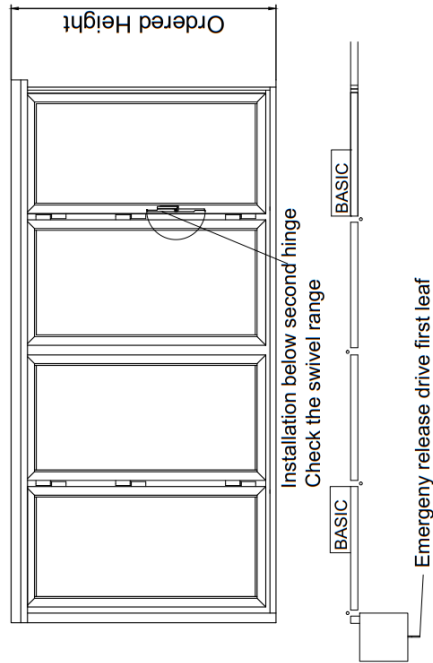

2-leaf set folding door 2+2, opening outwards
 Ordered Height 2000-3199mm and Ordered Height >3750mm

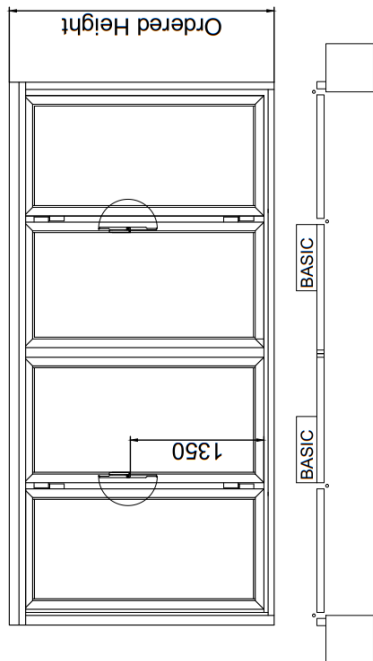

2-leaf set folding door 2+2, opening outwards
 Ordered Height 3200-3749mm

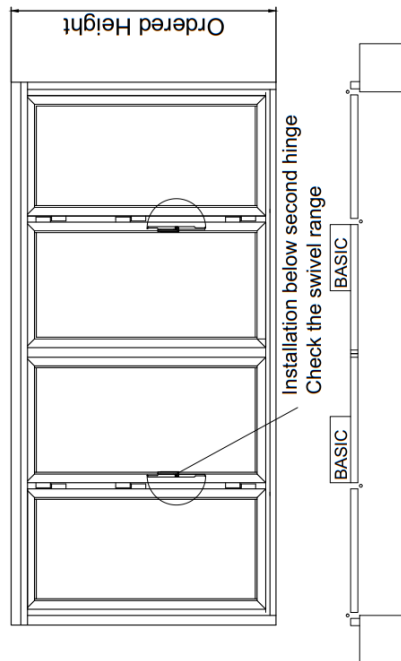

5 Disassembly and disposal

5.1 Disassembly

Disassembling the folding door must be performed by a specialist company and two specialist fitters.

The door must be disassembled in the following order:

1. Close the door
2. Remove drive (if installed)
3. Remove running gear bolt
4. Disassemble leaves applying the reverse order of installing them
5. Remove door frame



Don't let any parts fall down!

Danger

5.2 Disposal

If disposal is chosen, the individual components must be separated by their material type and recycled.

Customer service address

SCHNEIDER Torsysteme Gesellschaft m. b. H.
Kalzitstraße 1, A-4611 Buchkirchen (Austria)

Tel.: +43/7243/54588-0

E-Mail: office@schneider.co.at

Web: <http://www.schneider.co.at>