

Porte pliante
Porte pliante alu AL601F 2.0
Porte pliante alu AL602F
Porte pliante alu à rupture thermique
AL603F
Porte pliante acier ST602F
BR600

TECHNIQUE
Version 2024/01

SCHNEIDER Torsysteme Ges.m.b.H.
Kalzitstrasse 1
A-4611 Buchkirchen
Tél. +43 7243/545 88-0
Web.www.schneider.co.at



Valable à compter du 12.01.2024

Toute documentation antérieure devient caduque. Sous réserve de modifications techniques, d'erreurs d'impression et de typographie, de différences de couleurs dues à l'impression. Illustrations fournies uniquement à titre indicatif.

Schéma du système portes pliantes

AL601F 2.0, AL602F, AL603F, ST602F

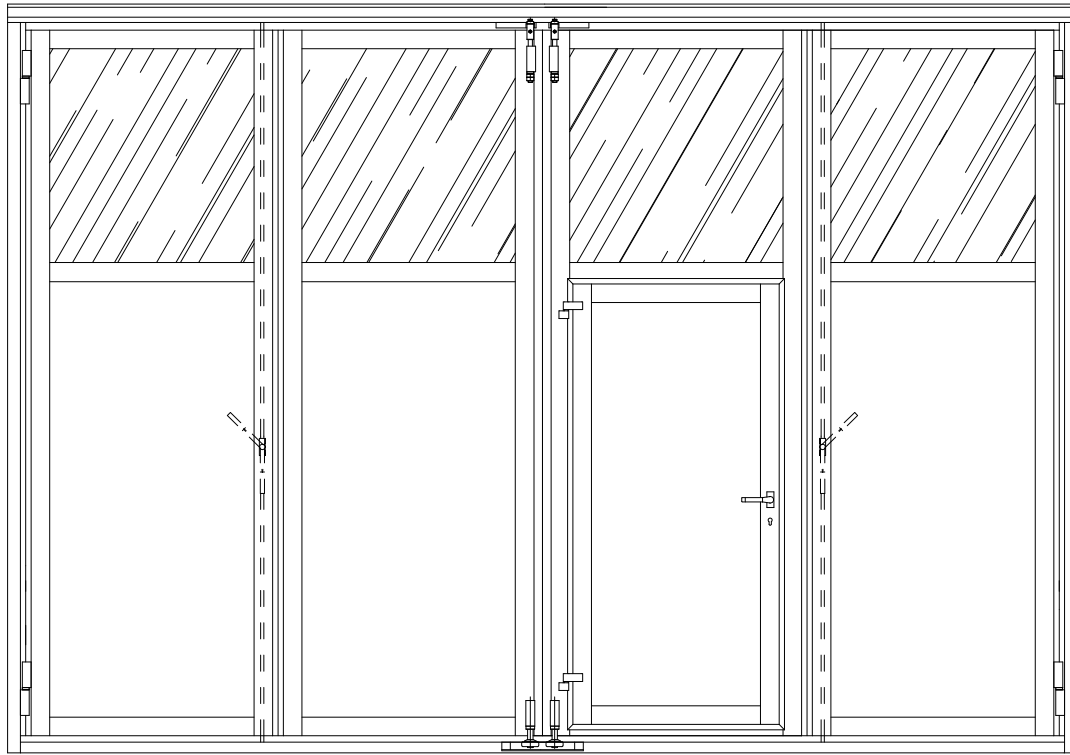

Coupe horizontale

Coupe verticale

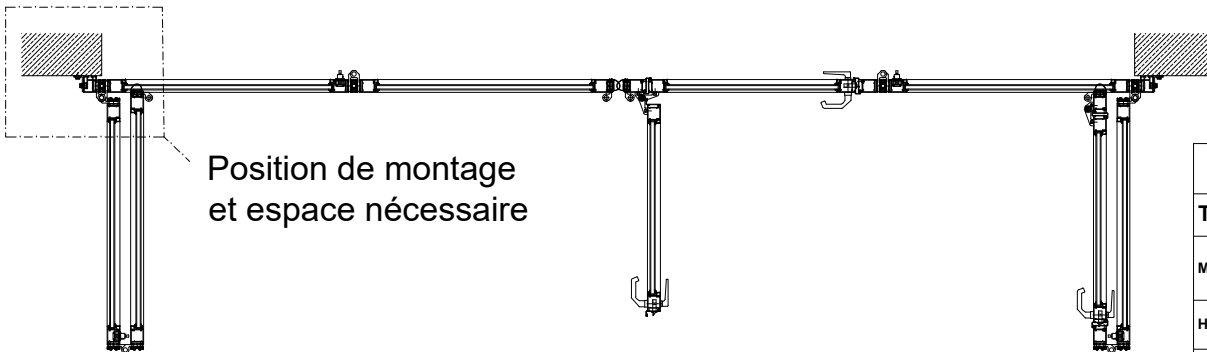
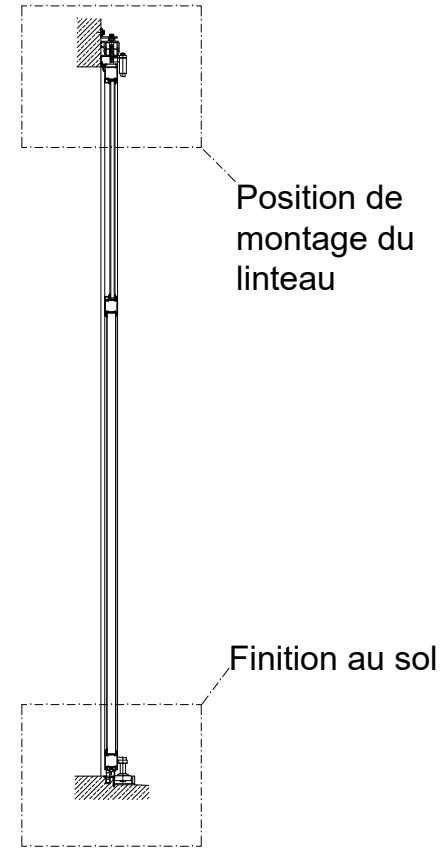

Portes pliantes gamme de dimensions

Type	AL601F 2.0	AL602F	AL603F	ST602F ST602SF
Material	Aluminium	Aluminium	Aluminium à rupture thermique	Acier
Hauteur max. de la porte BB x BH	10400x4800 mm	15600x5600 mm	15600x5600 mm	15600x7000 mm
Largeur max. du vantail	1300 mm	1300 mm	1300 mm	1300 mm

Vantaux-Espace nécessaire

AL601F 2.0

Ouverture de 90°

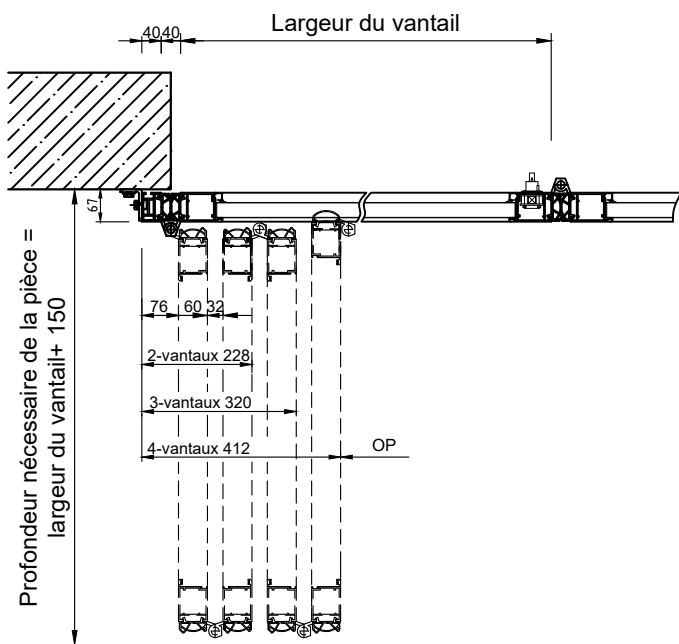

AL602F AL603F ST602F

Ouverture de 90°

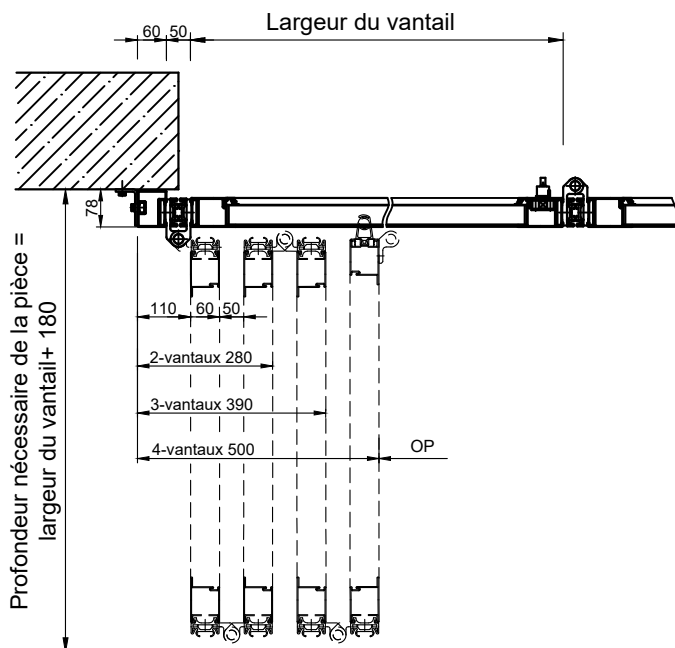

AL601F 2.0

Déviaton de 180° (3 vantaux max., manuel)

(aucun guidage continu au sol n'est possible)

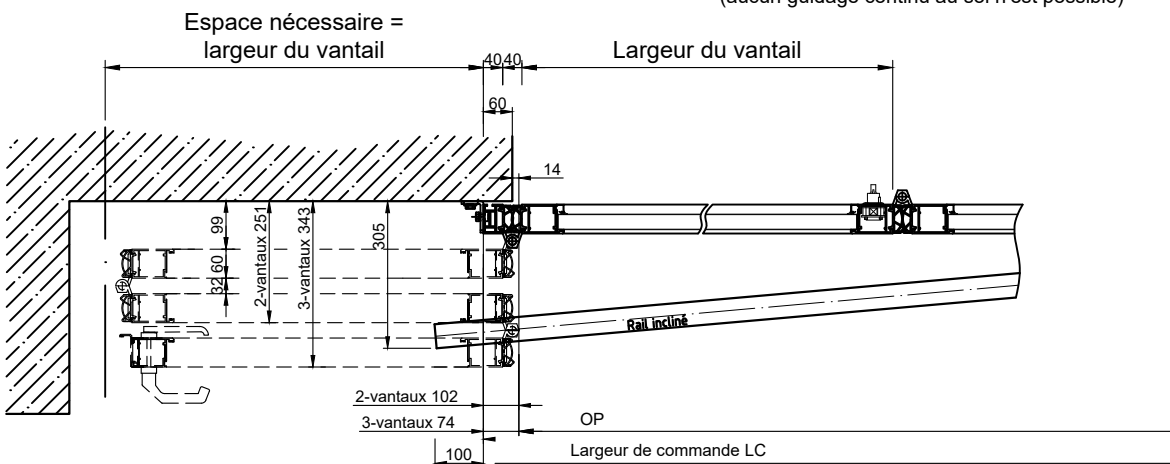

AL602F AL603F ST602F

Déviaton de 180° (3 vantaux max., manuel)

(aucun guidage continu au sol n'est possible)

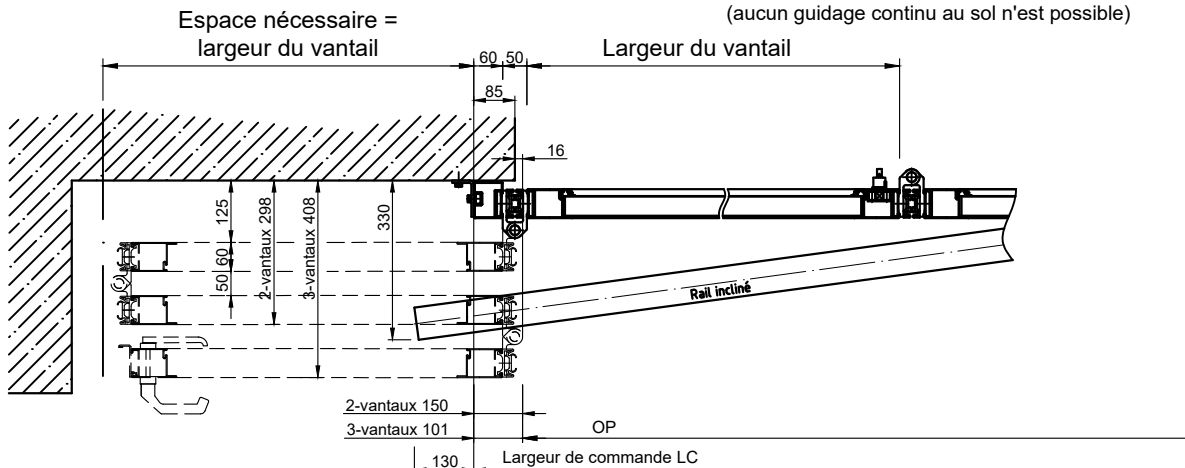

Position de montage du linteau devant/derrière l'intrados

AL601F 2.0

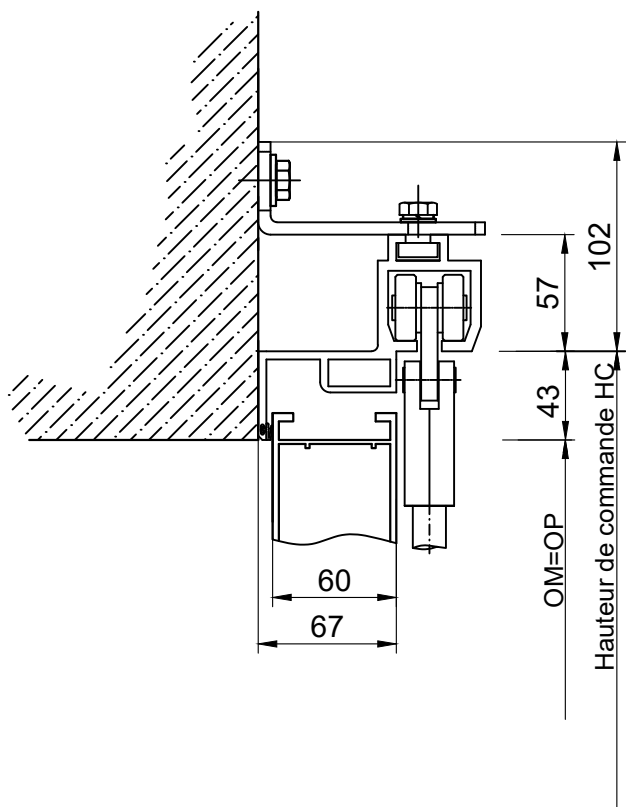

AL602F

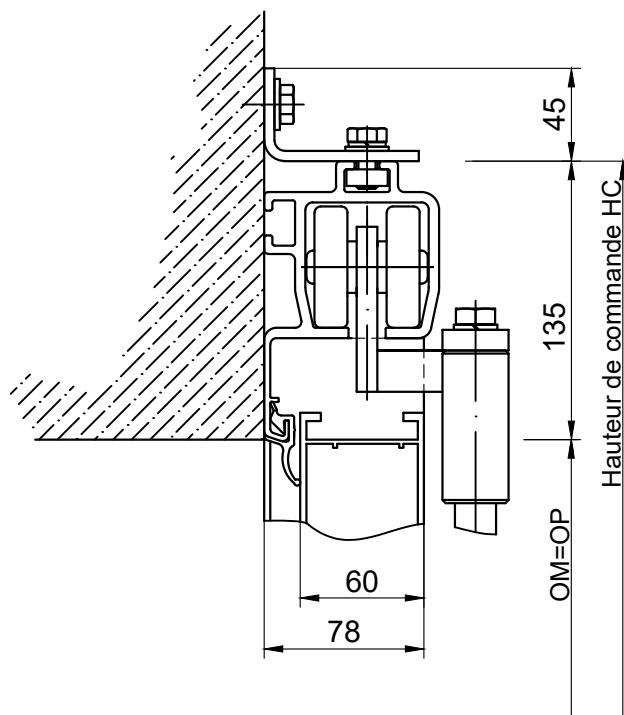

AL603F

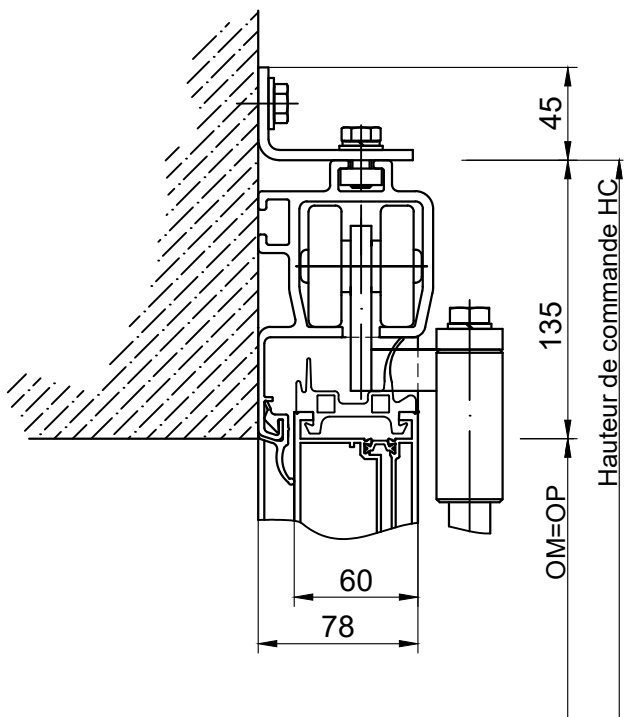

ST602F

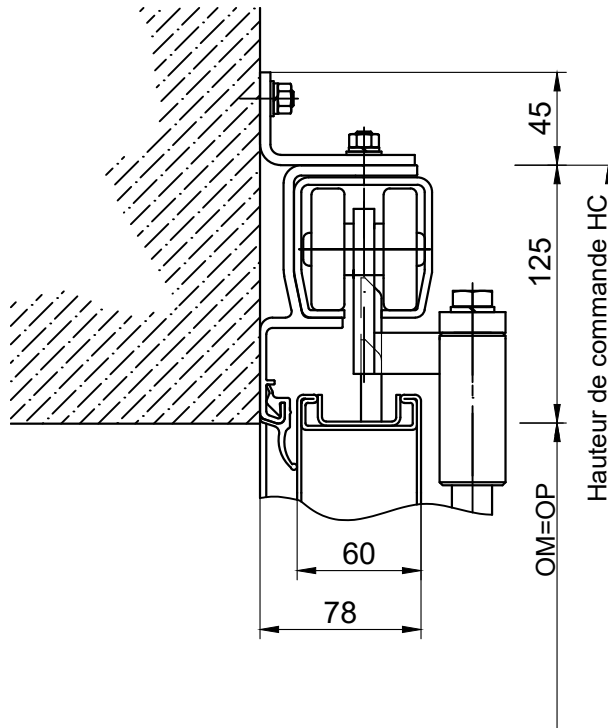

Position de montage du linteau dans l'intrados

AL601F 2.0

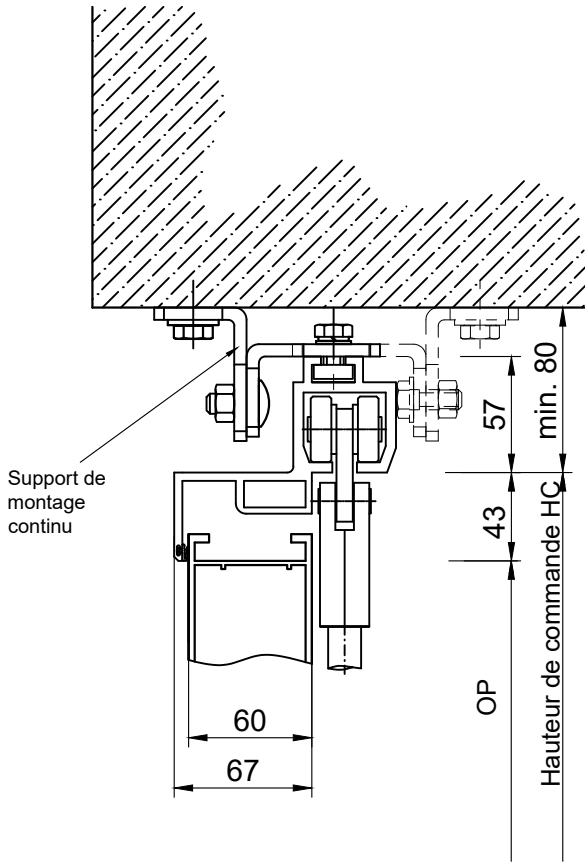

AL602F

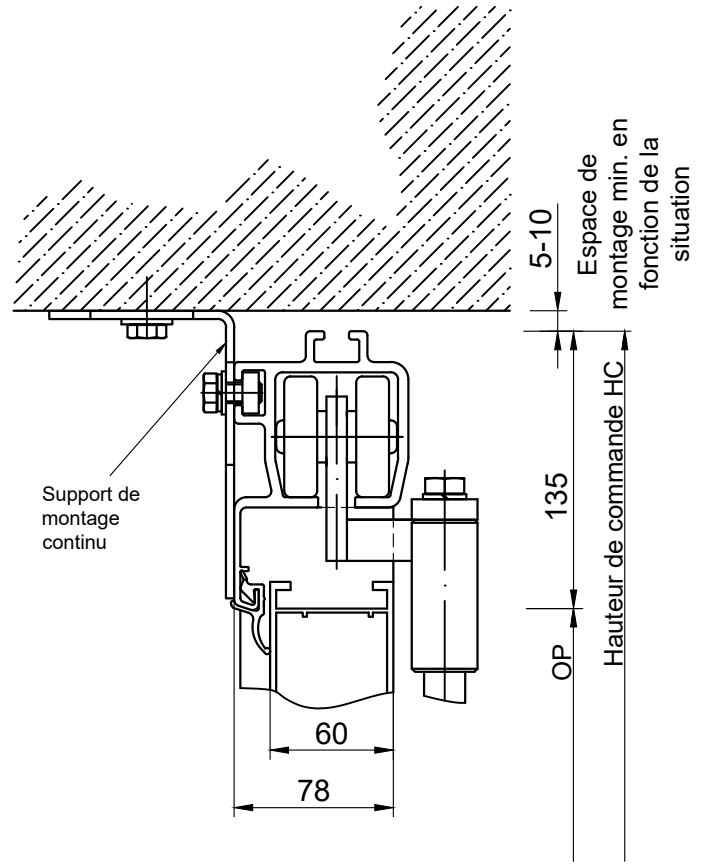

AL603F

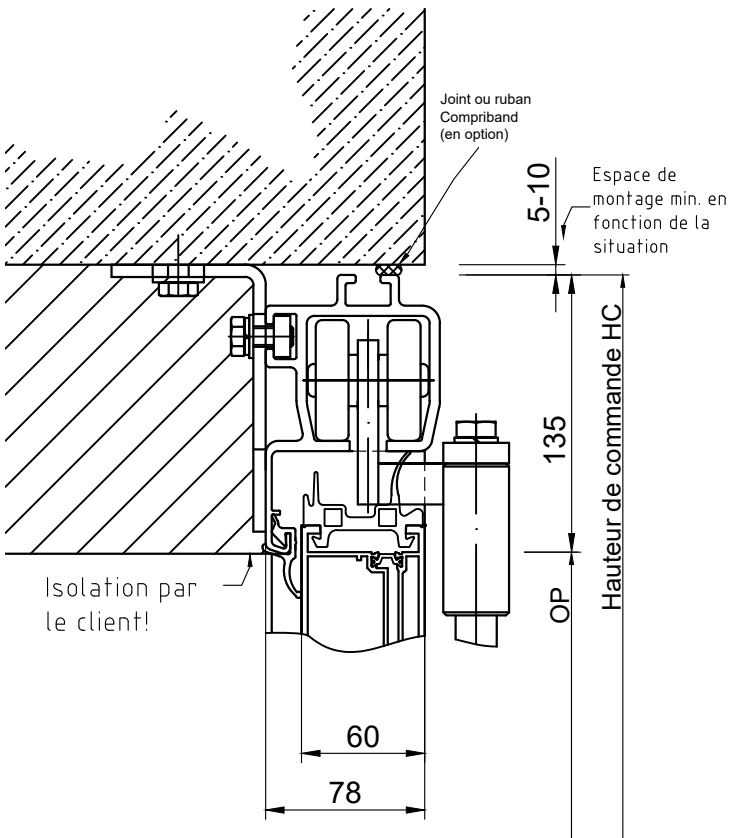

ST602F

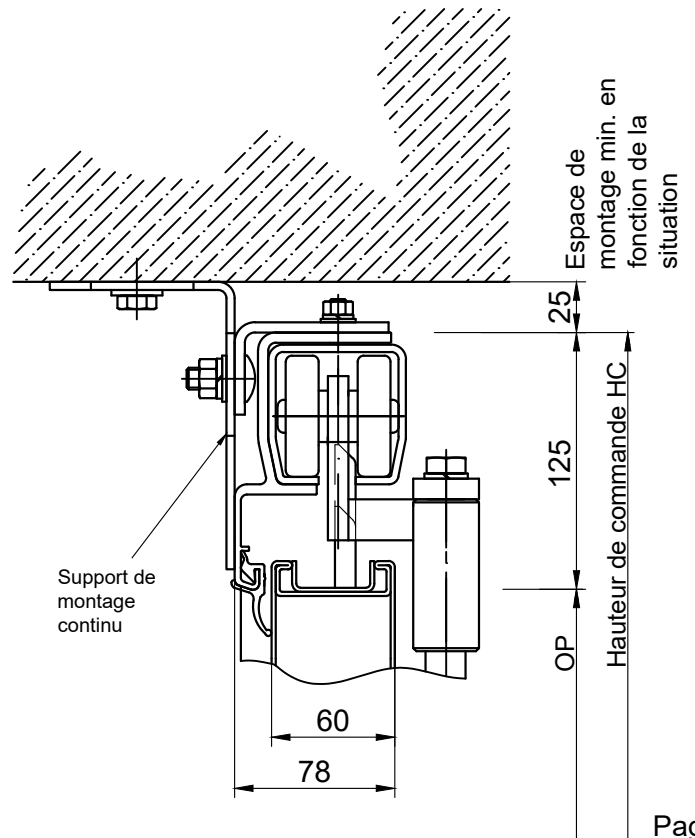

Position de montage du linteau

Montage en angle

AL601F 2.0

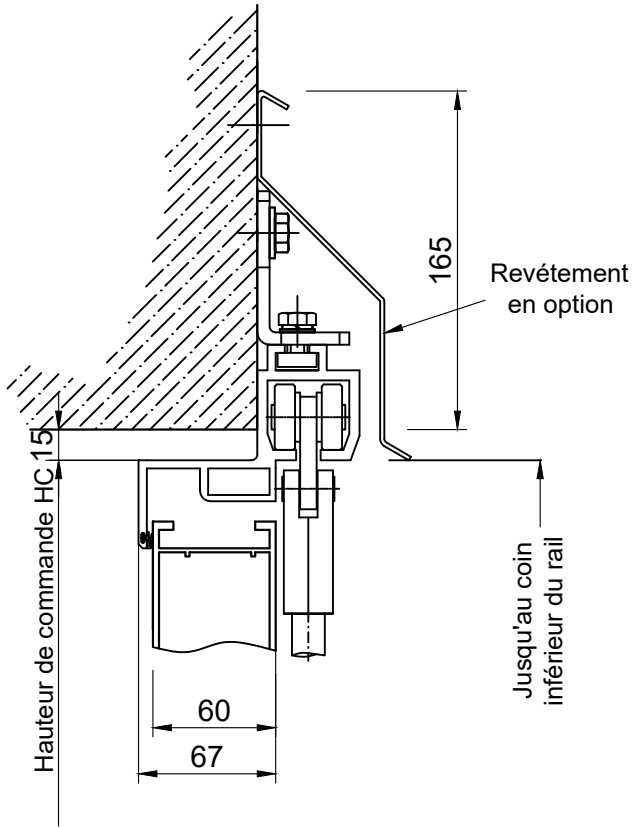

AL602F

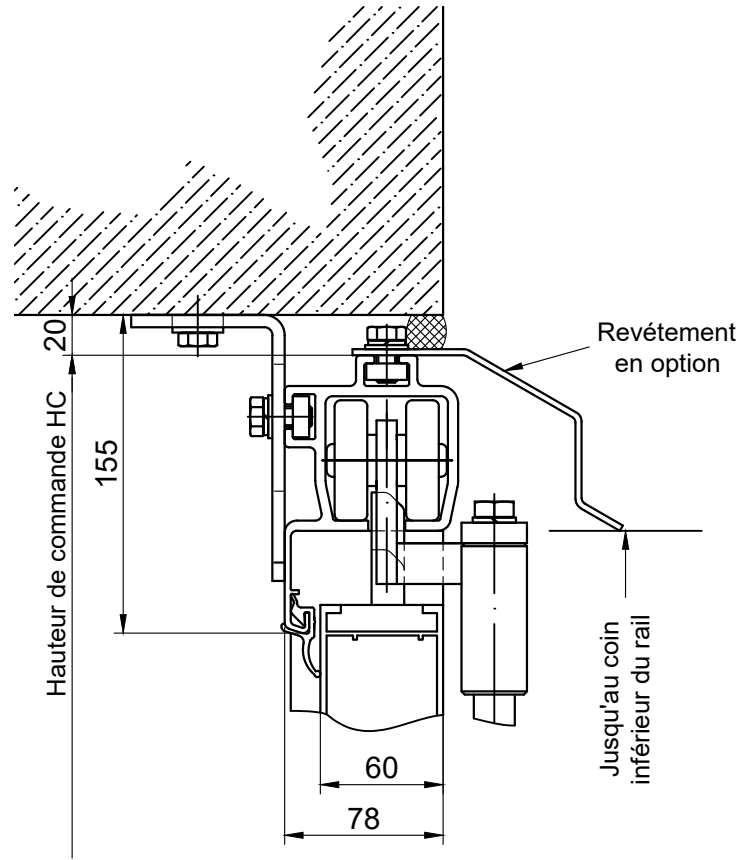

AL603F

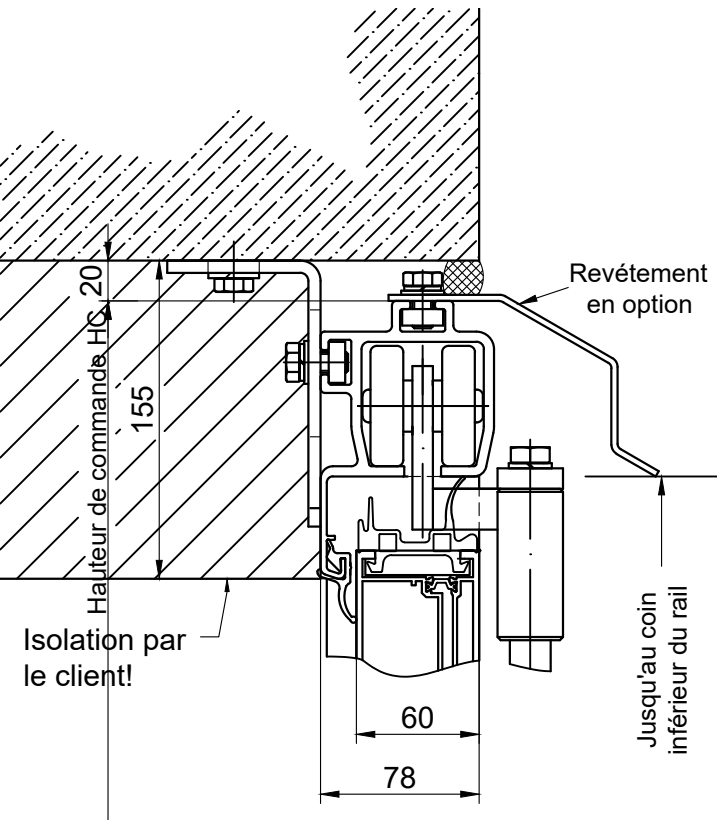

ST602F

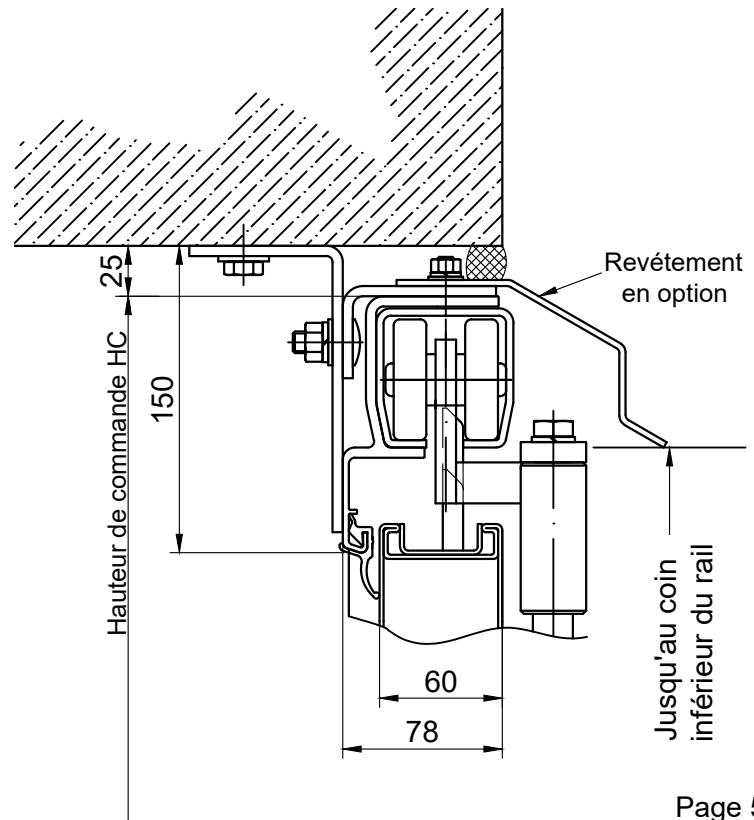

Position de montage devant/derrière l'intrados sur le côté

AL601F 2.0

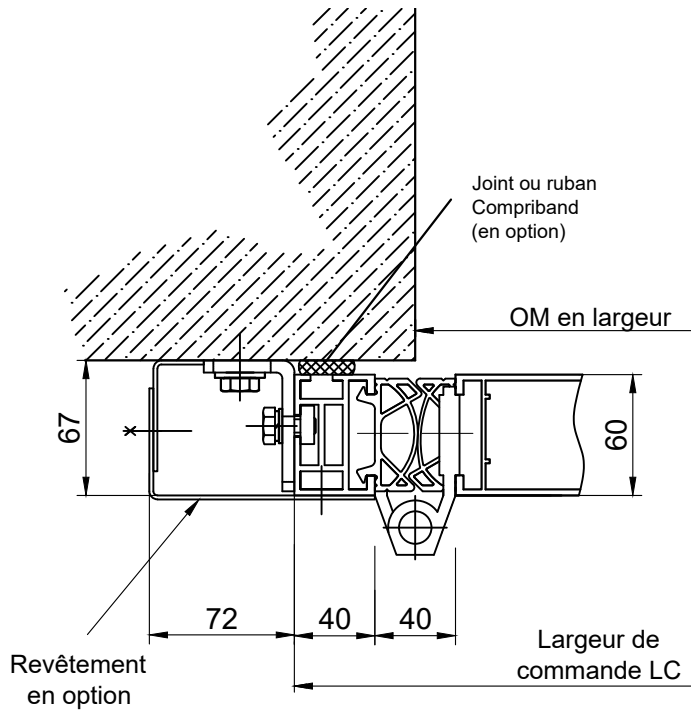

AL602F

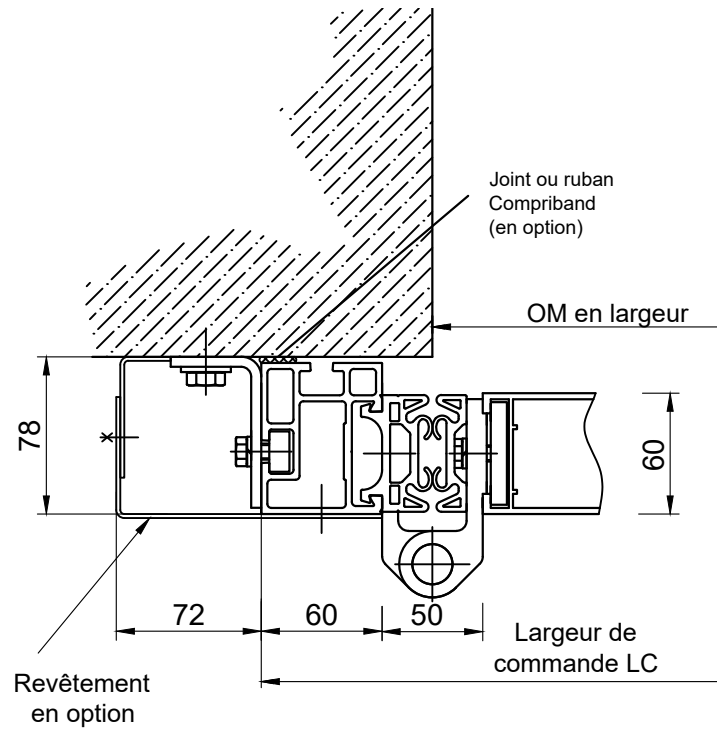

AL603F

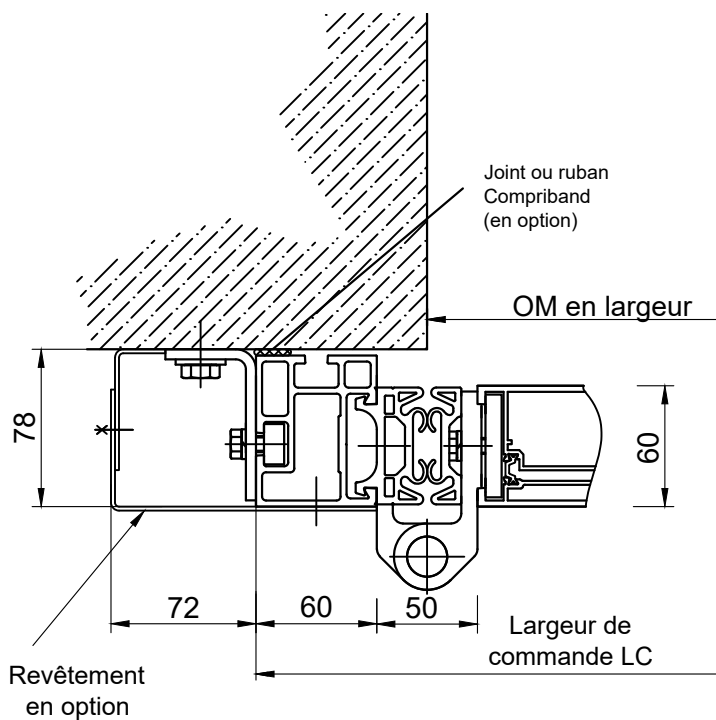

ST602F

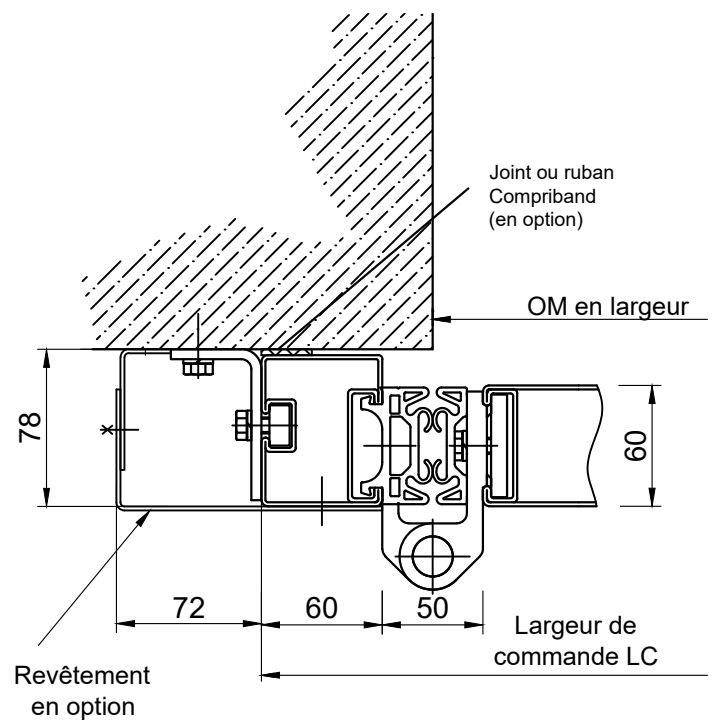

Position de montage dans l'intrados sur le côté

AL601F 2.0

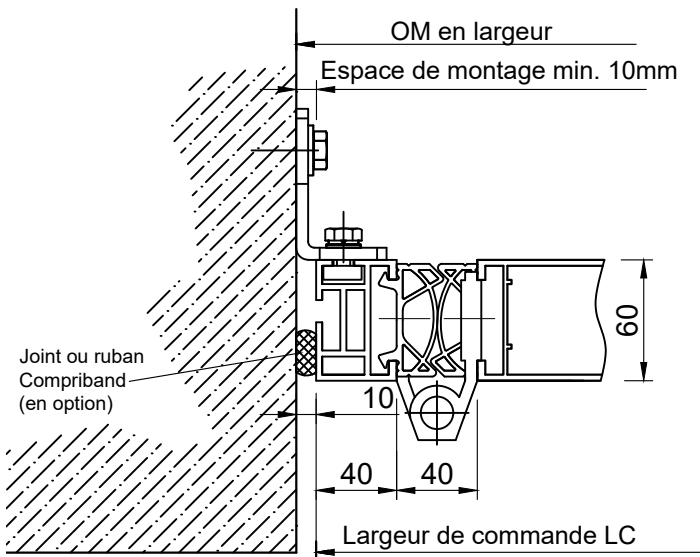

AL602F

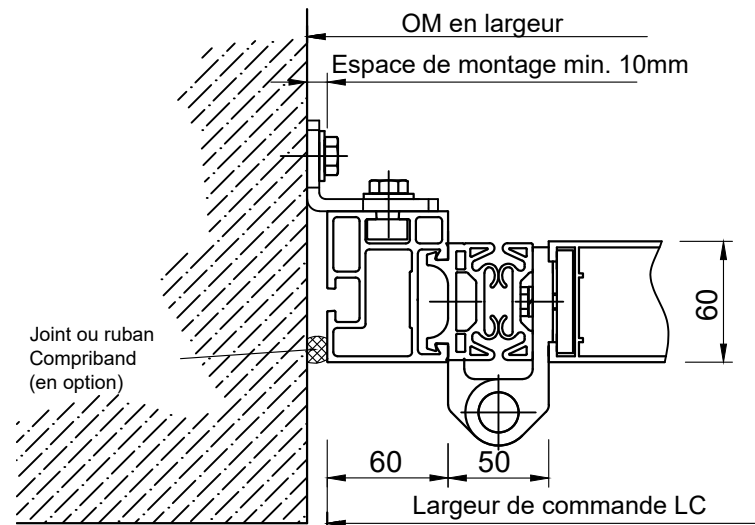

AL603F

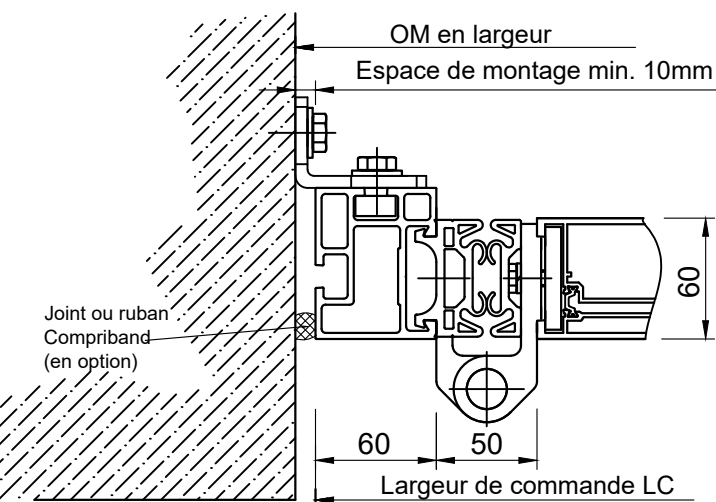

ST602F

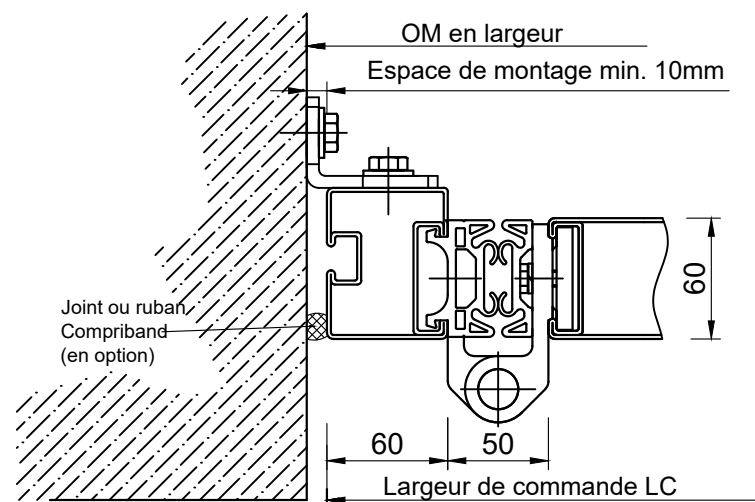

Position de montage

Montage en angle sur le côté

AL601F 2.0

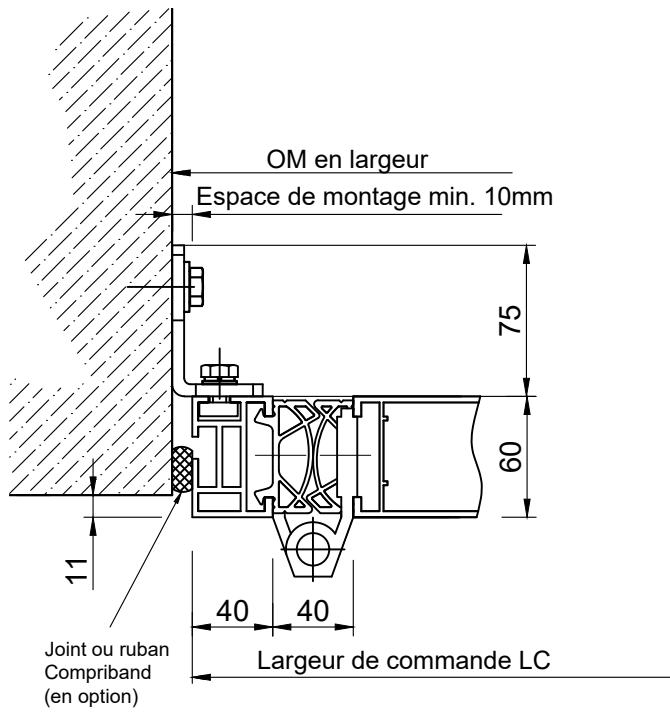

AL602F

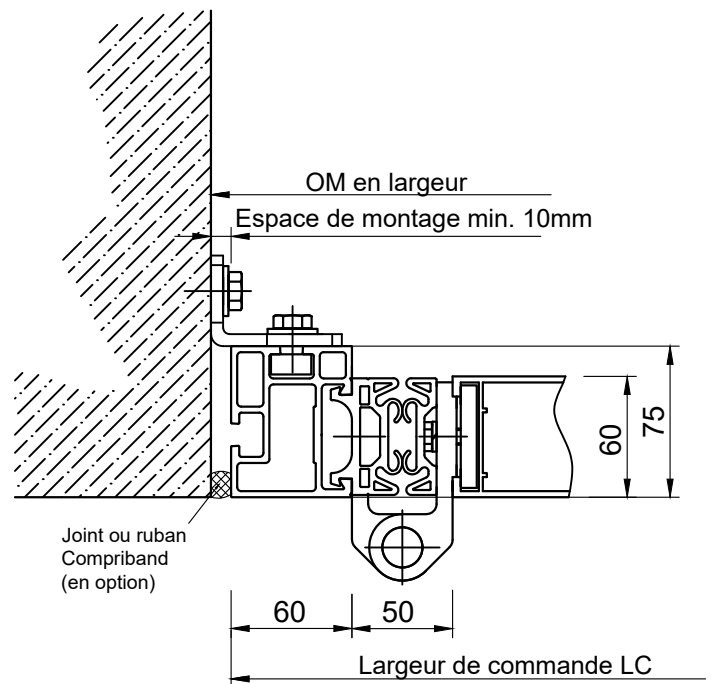

AL603F

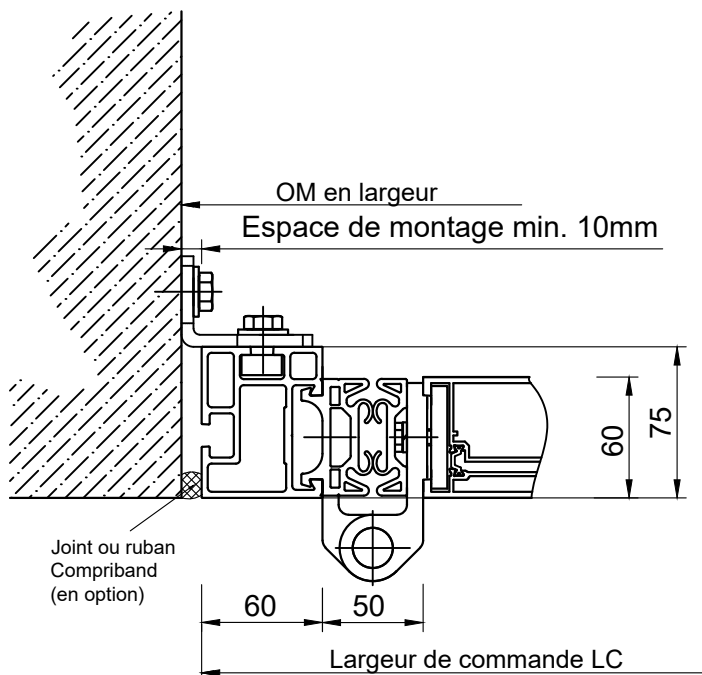

ST602F

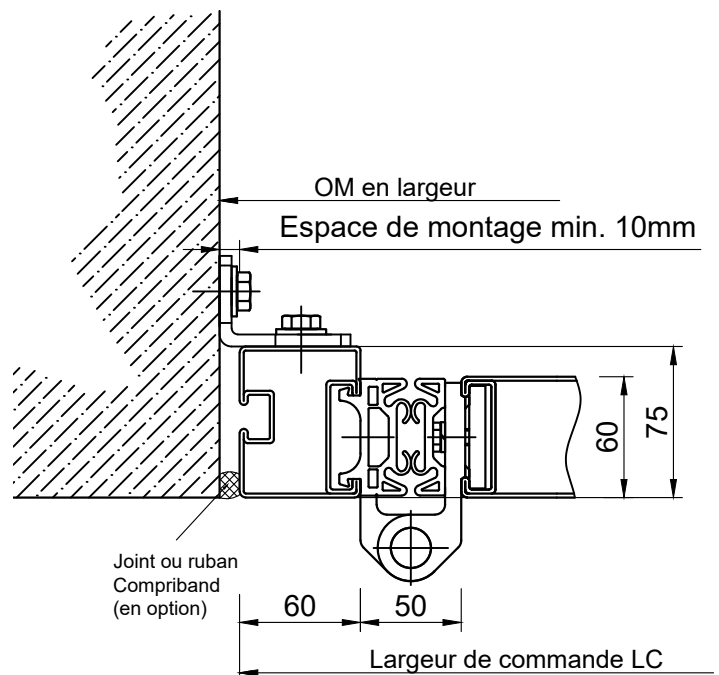

Rail de roulement 90° devant/derrière l'intrados linteau avec revêtement

AL601F

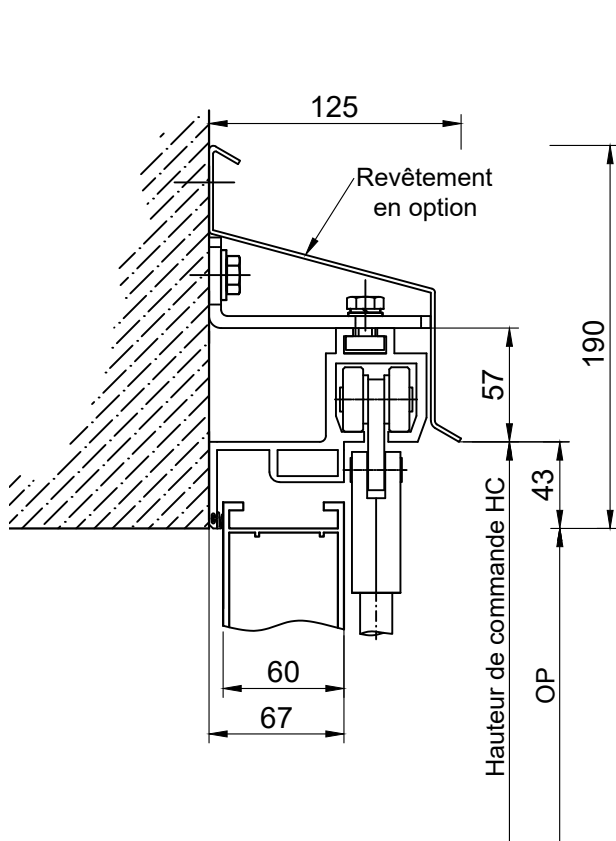

AL602F

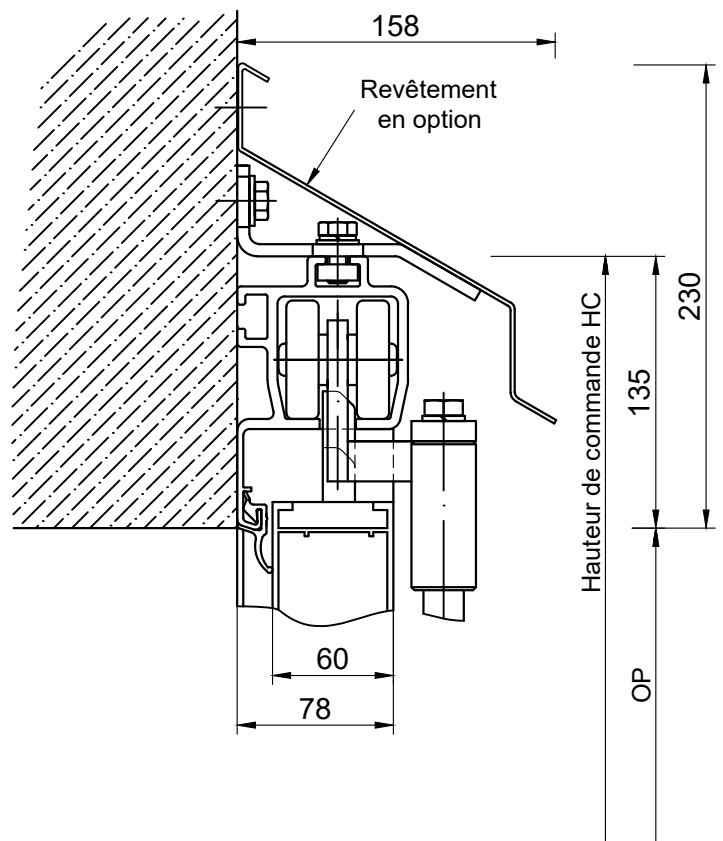

AL603F

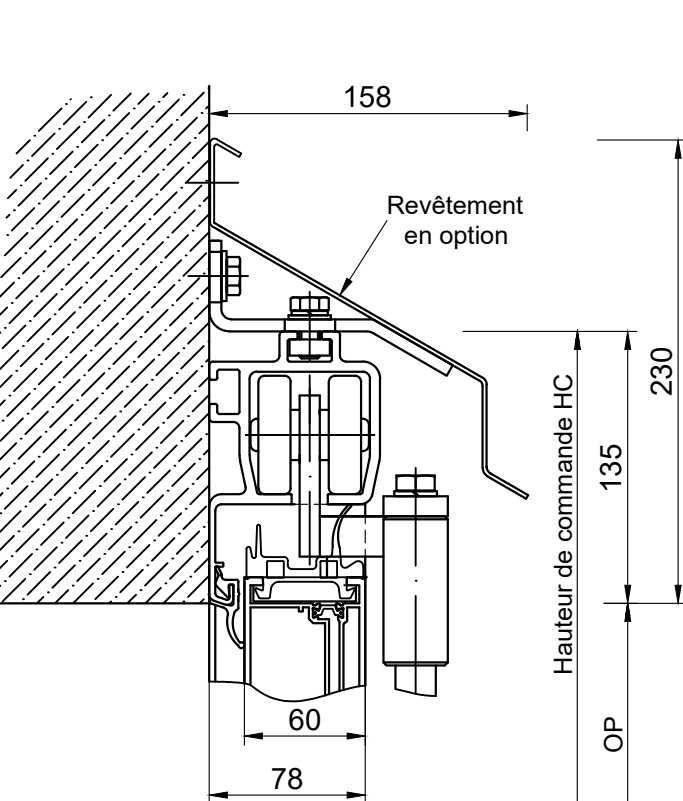

ST602F

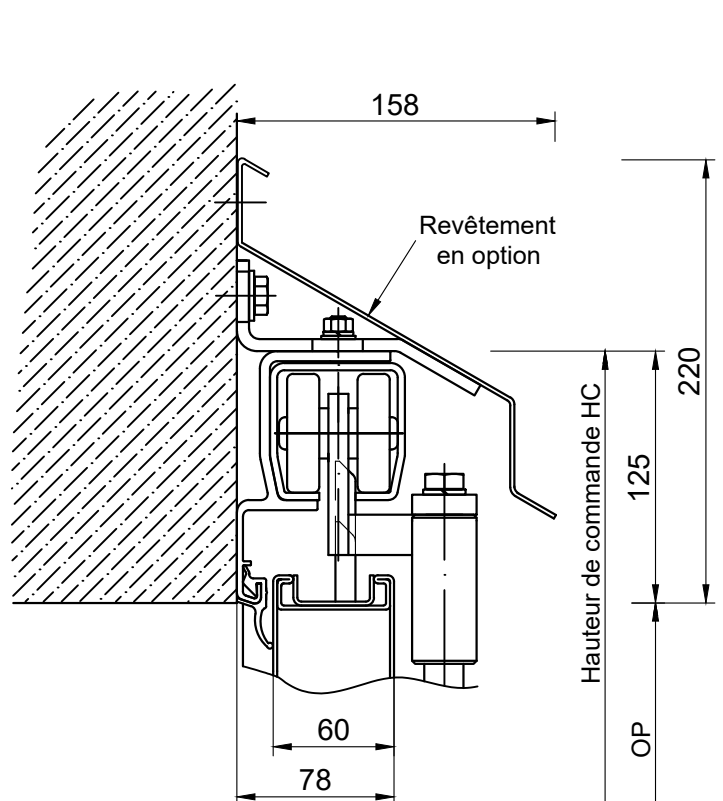

Rail de roulement 180° (aucun guidage continu au sol n'est possible) montage en angle avec revêtement

AL601F 2.0

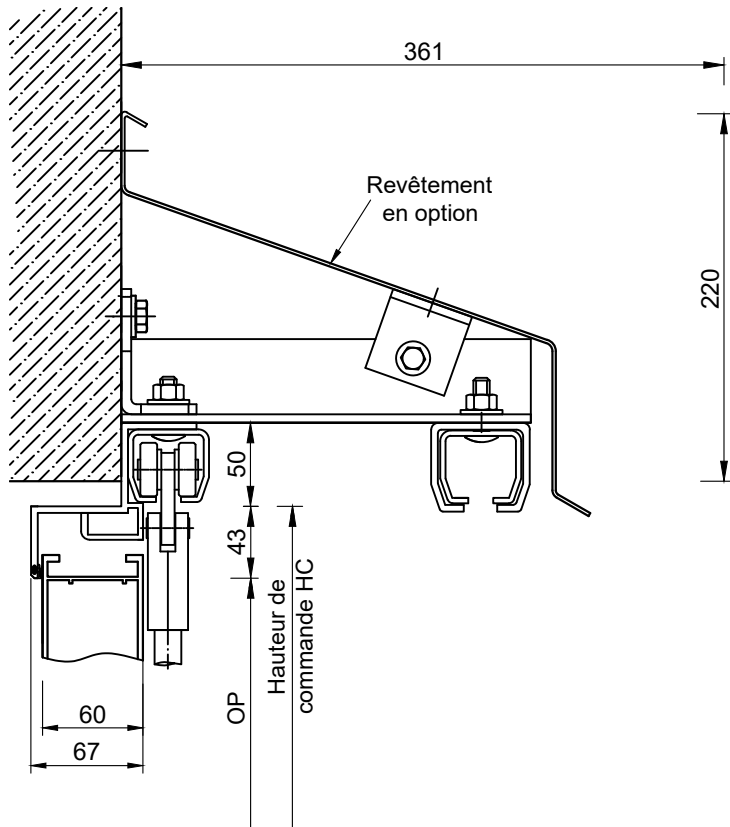

AL602F

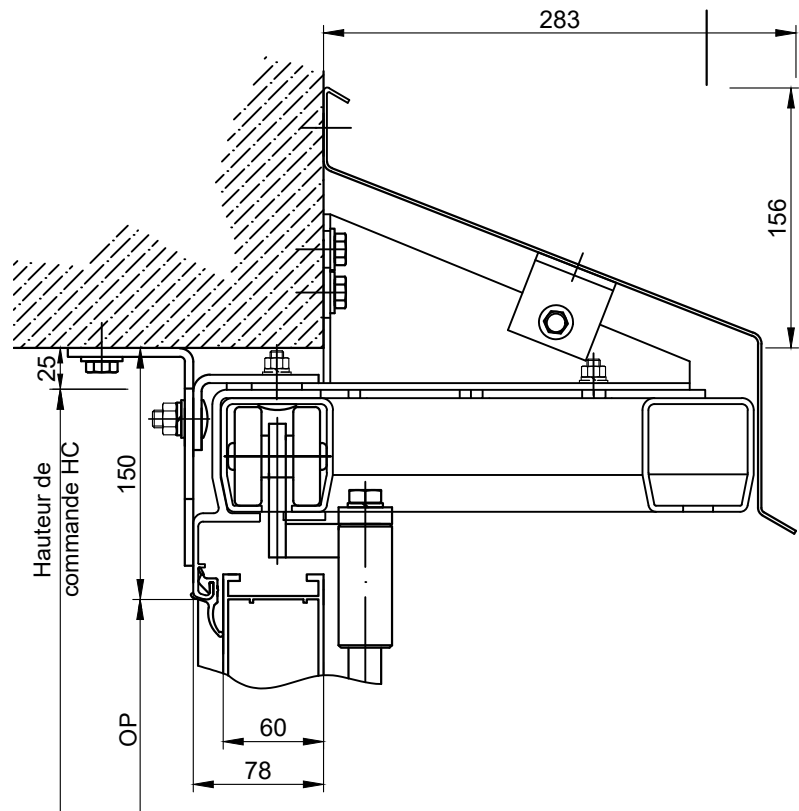

AL603F

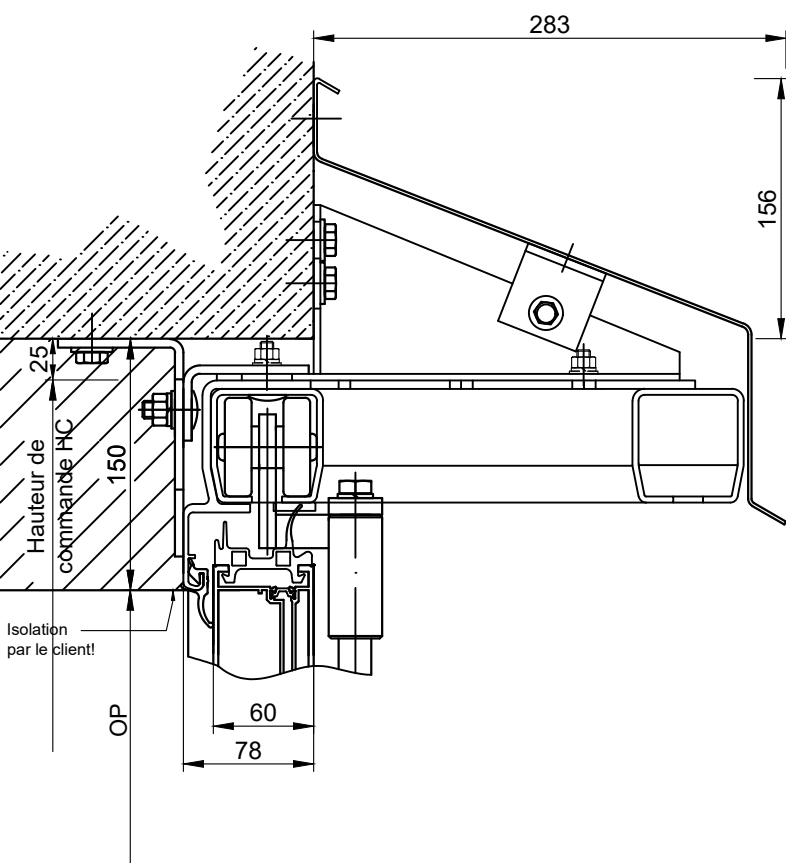

ST602F

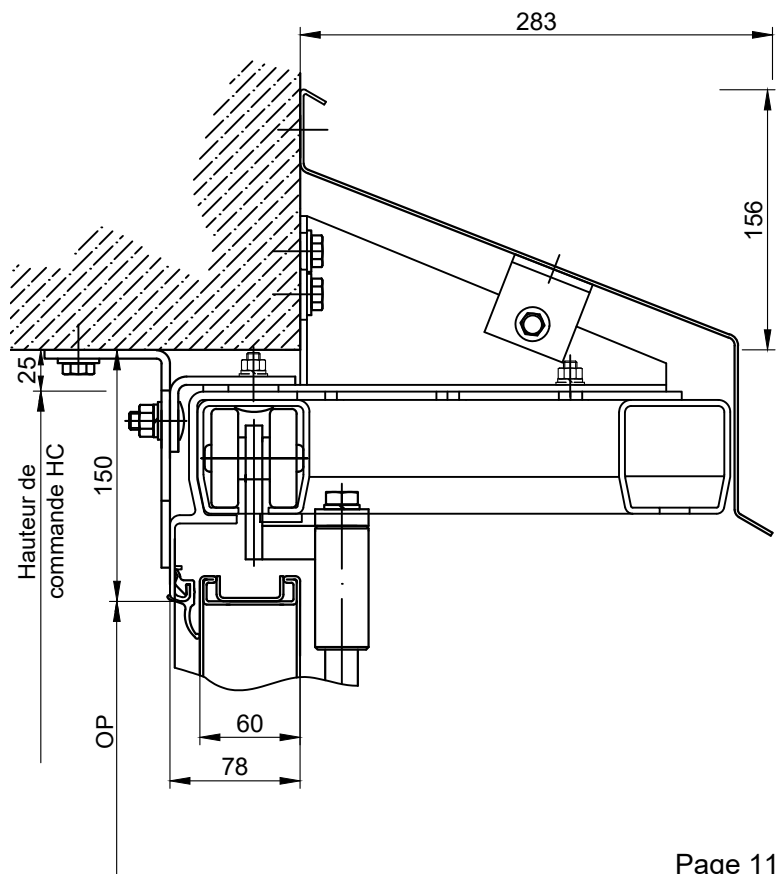

Rail de roulement 90° rail de roulement renforcé devant/derrière l'intrados linteau avec revêtement

AL601F

pas possible

AL602F

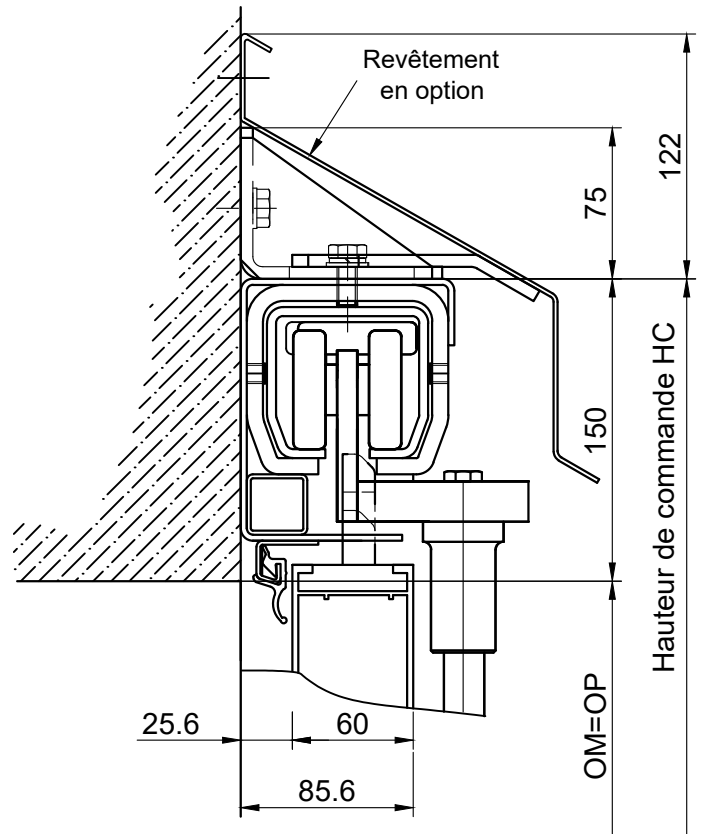

AL603F

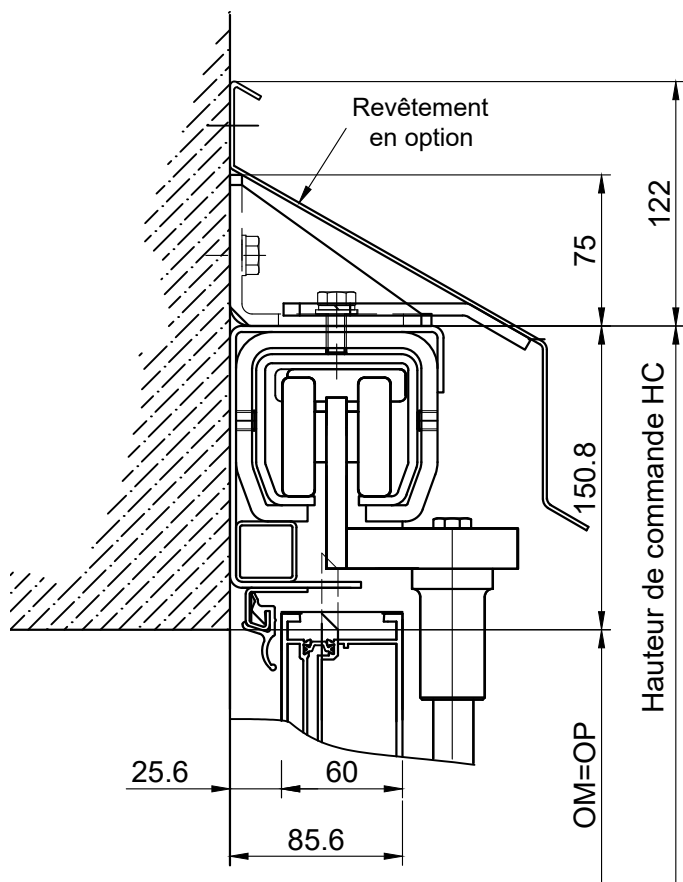

ST602F

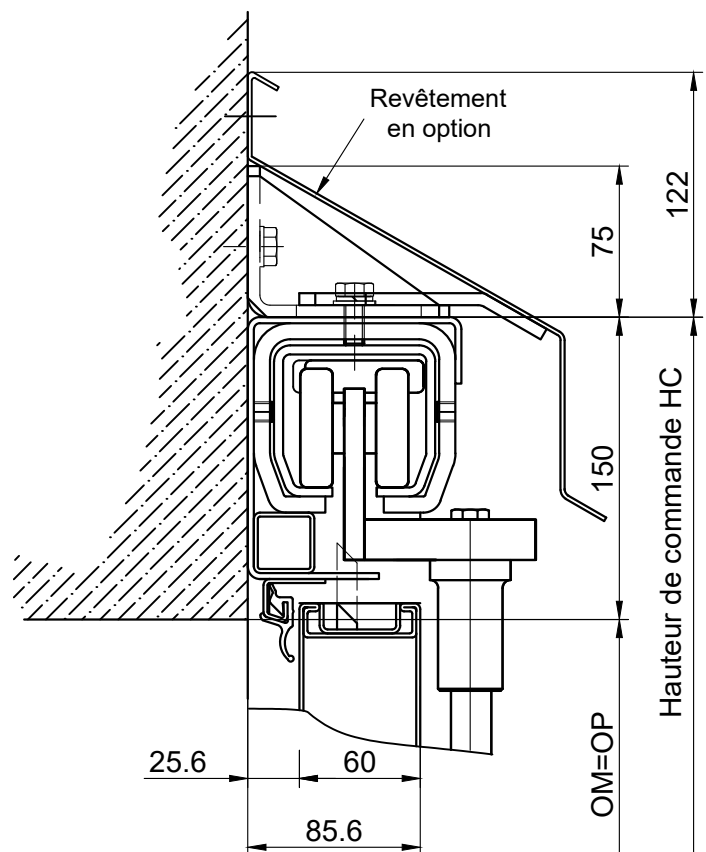

Rail de roulement 90° rail de roulement renforcé dans l'intrados

AL601F

pas possible

AL602F

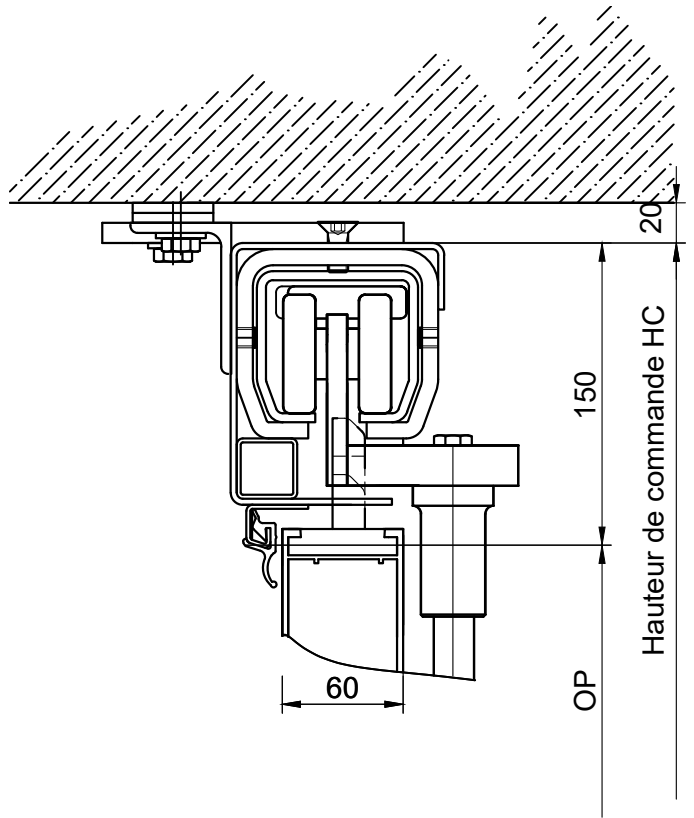

AL603F

ST602F

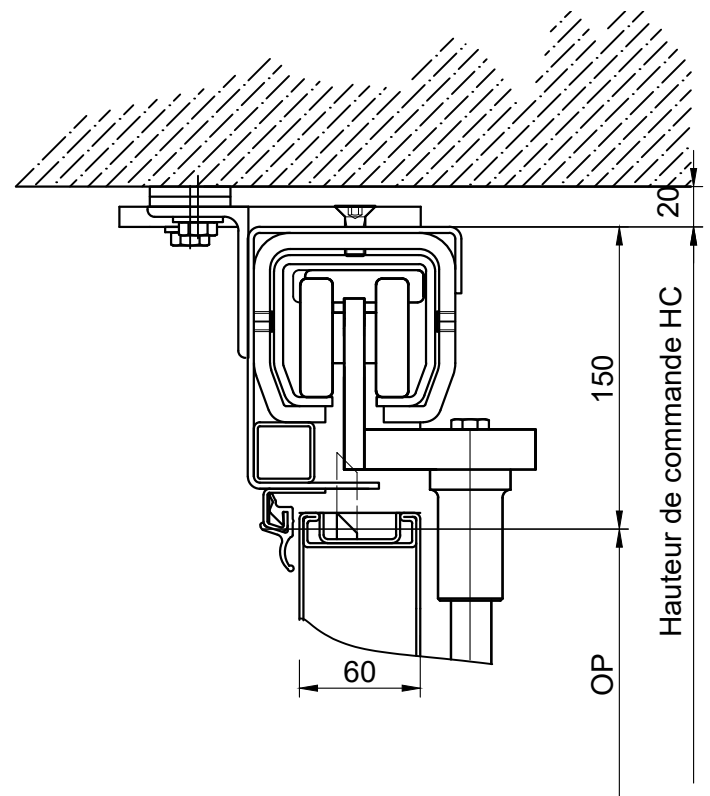
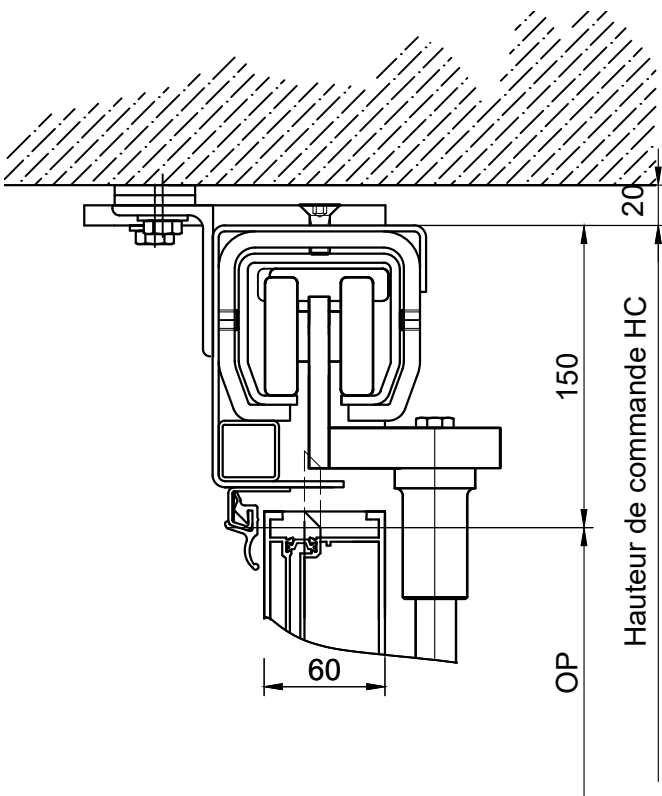

Finition au sol

Angle d'arrêt du seuil L50

Attention: 5% d'inclinaison dans le sens de l'ouverture

AL601F 2.0

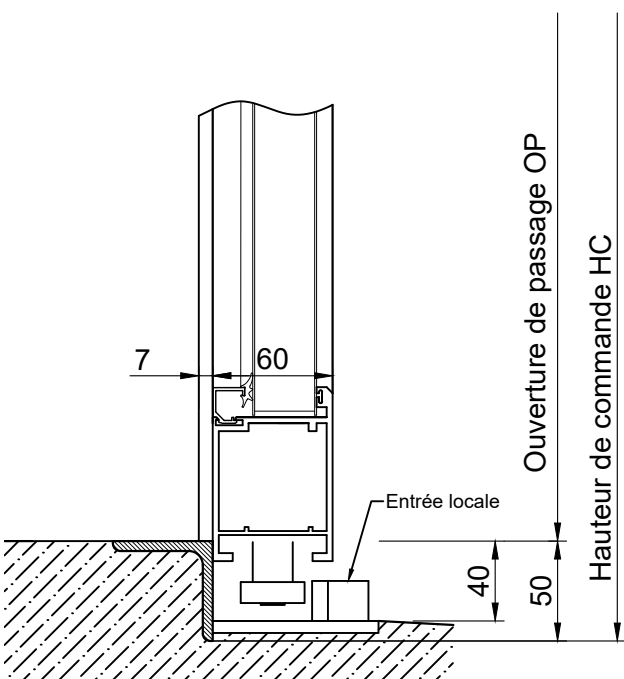

AL602F

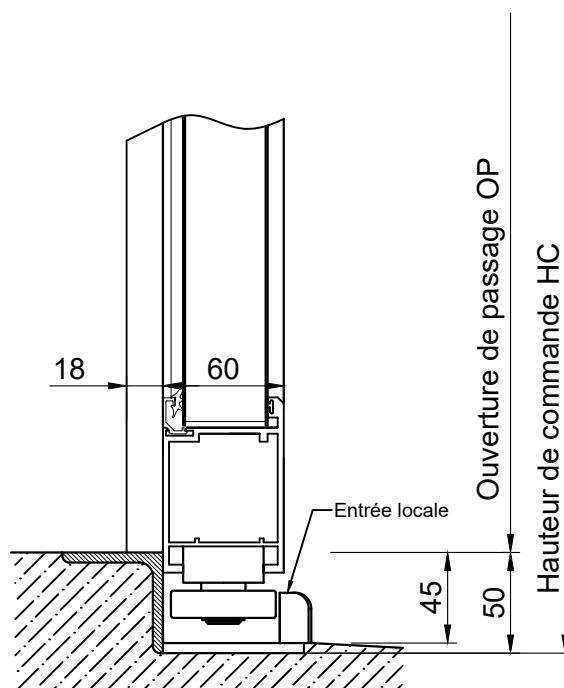

AL603F

pas possible

ST602F

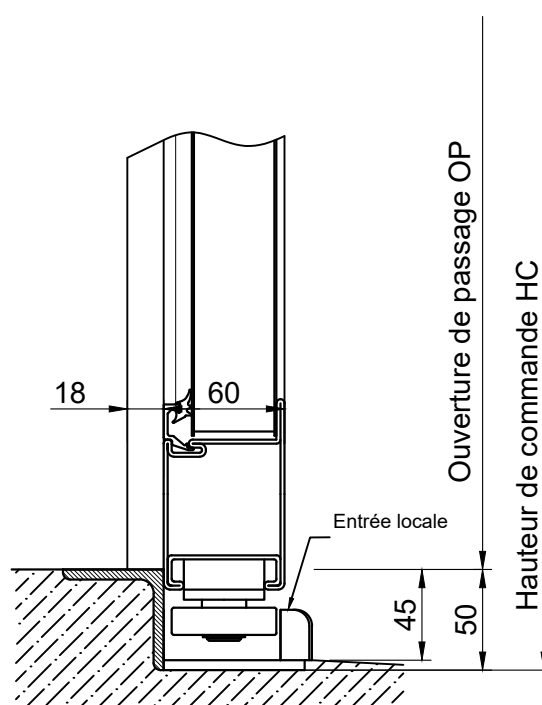

Finition au sol

Seuil L50D

Attention: 5% d'inclinaison dans le sens de l'ouverture

AL601F 2.0

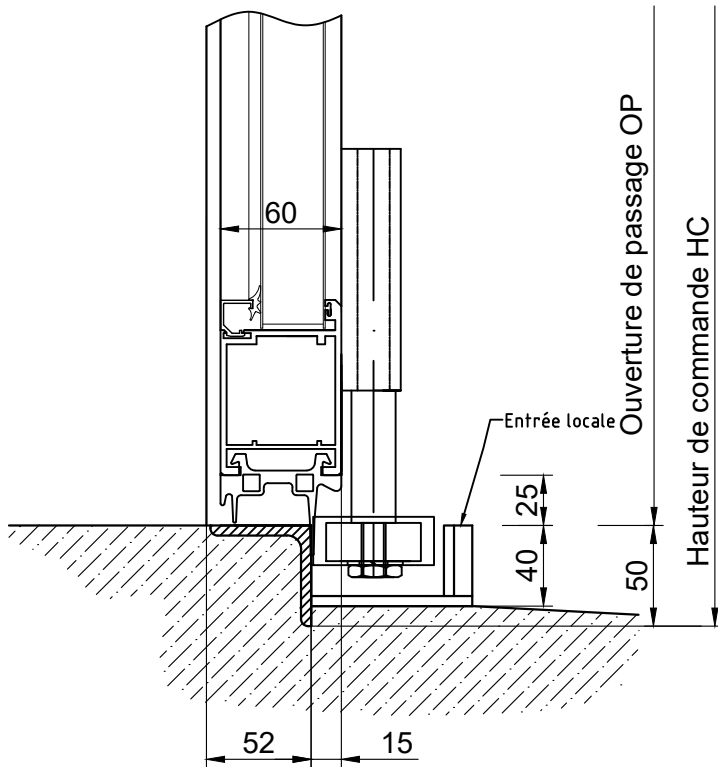

AL602F

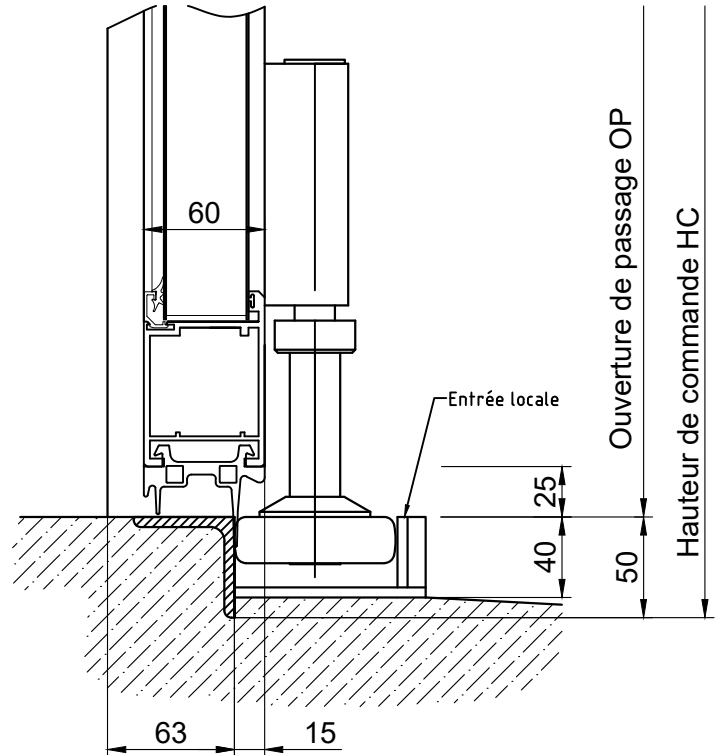

AL603F

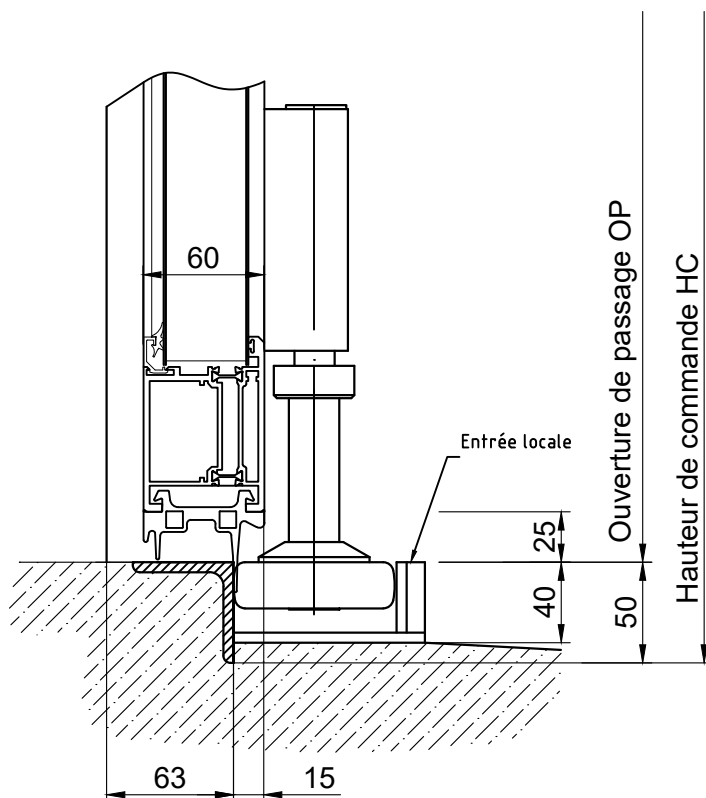

ST602F

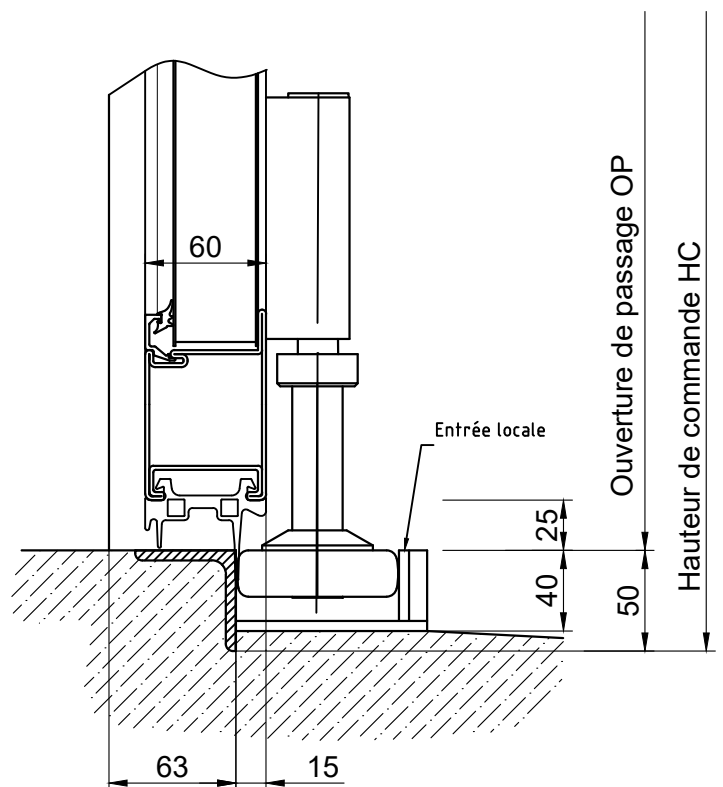

Finition au sol

Seuil U50D

Attention: 5% d'inclinaison dans le sens de l'ouverture

AL601F 2.0

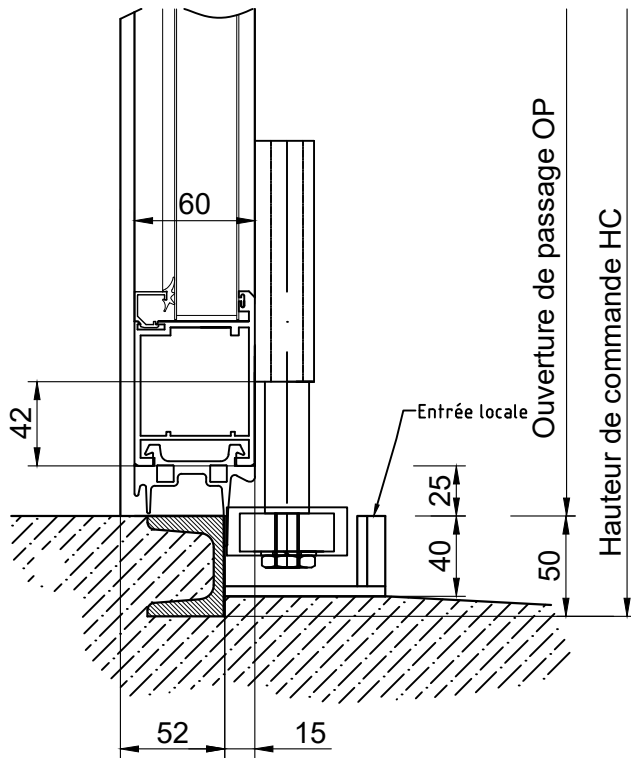

AL602F

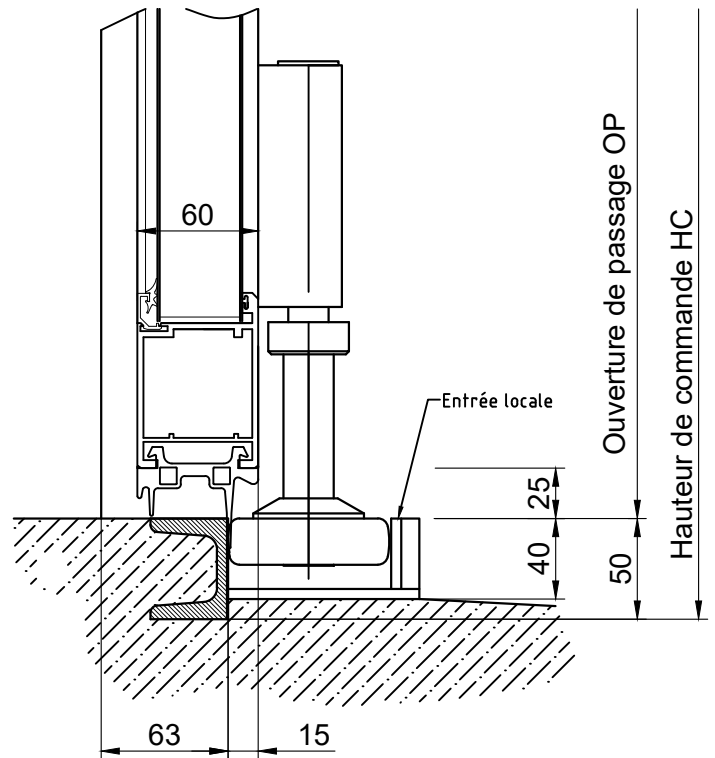

AL603F

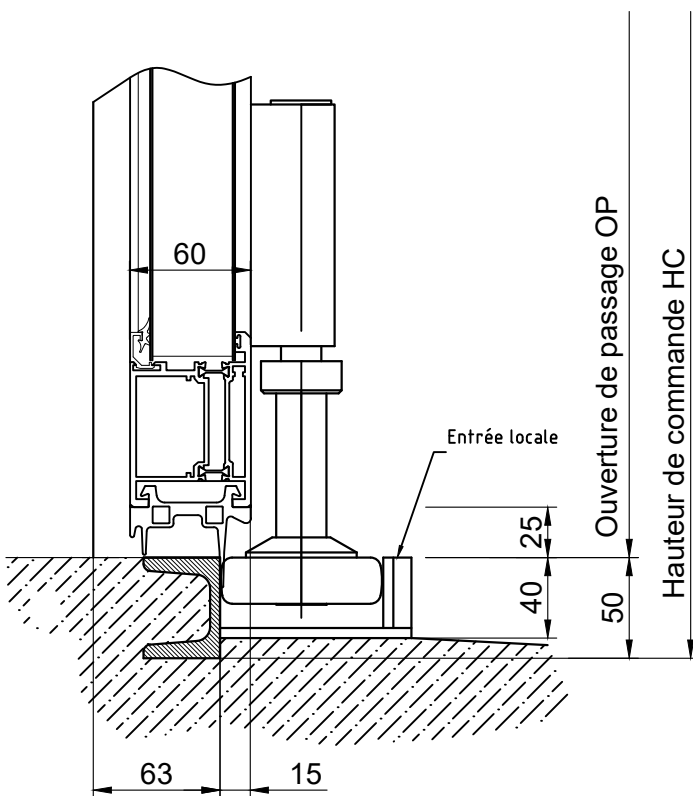

ST602F

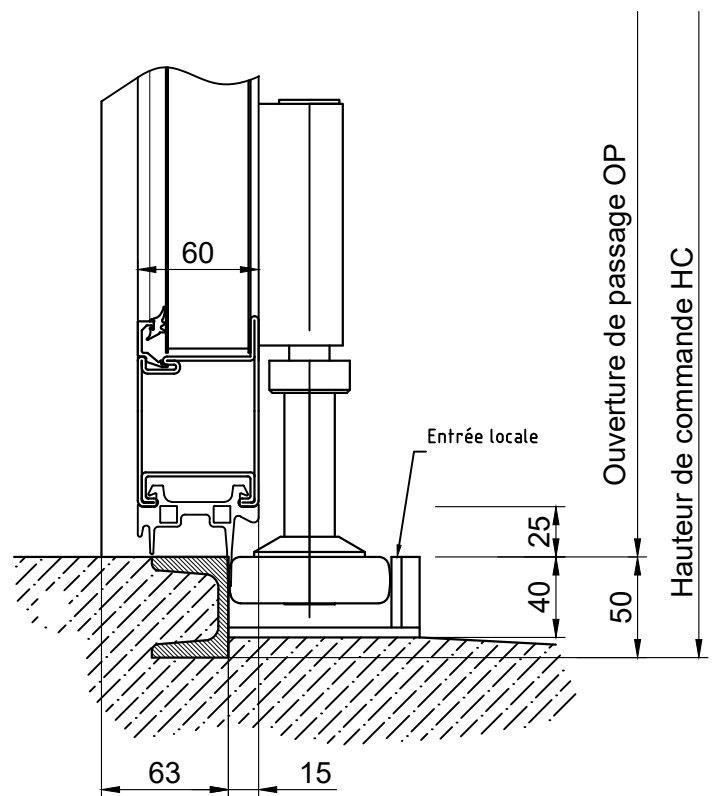

Finition au sol

Seuil support double DA

Attention: 5% d'inclinaison dans le sens de l'ouverture

AL601F 2,0

pas possible

AL602F

pas possible

AL603F

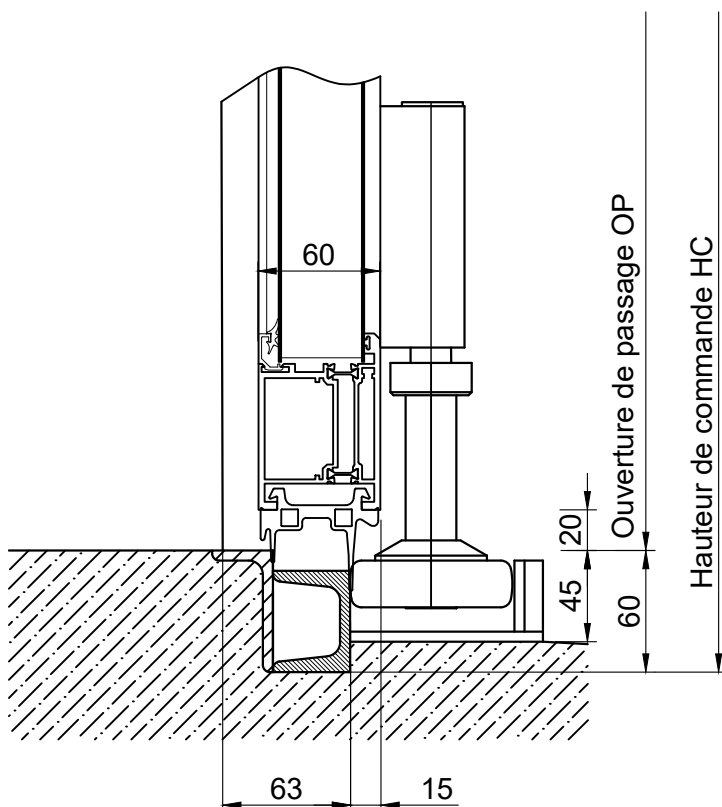

ST602F

pas possible

Finition au sol

Seuil plate en acier S10D/S20D

Attention: 5% d'inclinaison dans le sens de l'ouverture

AL601F

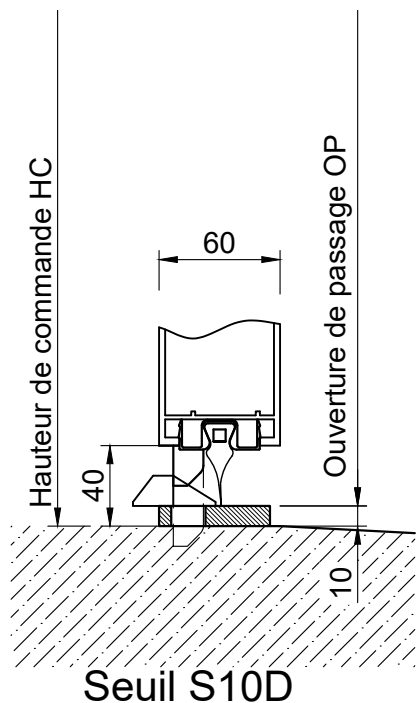

AL602F

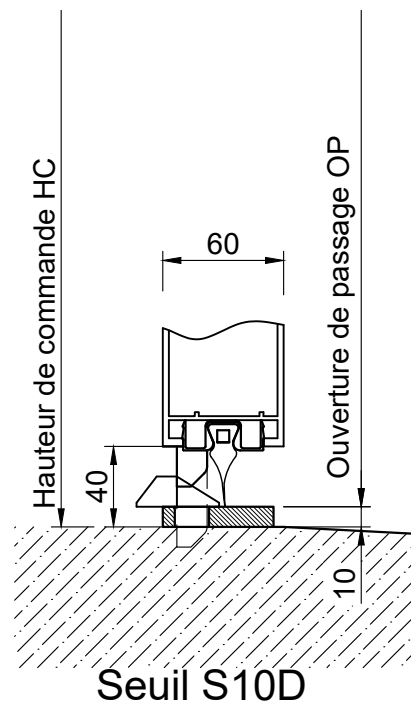

AL603F

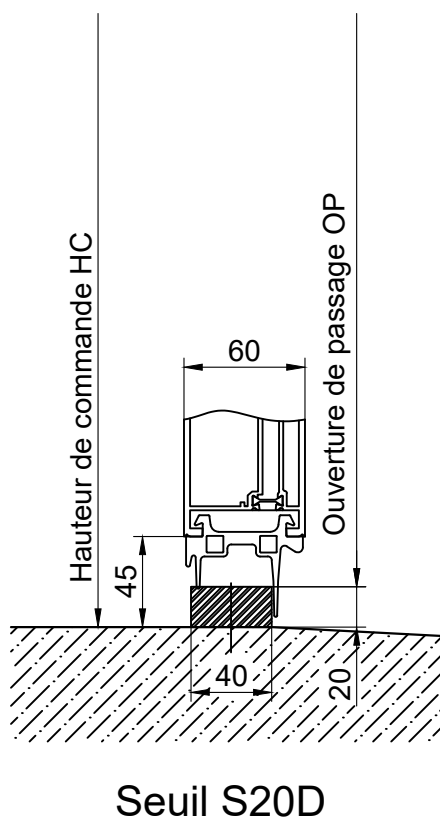

ST602F

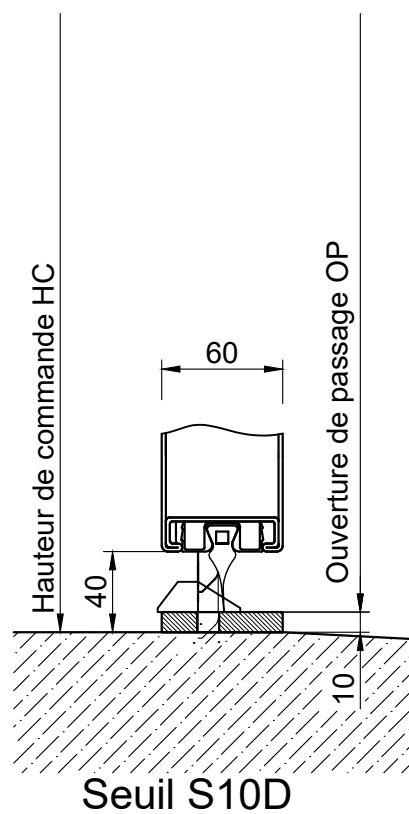

Finition au sol Boulon d'arrêt RA

Attention: 5% d'inclinaison dans le sens de l'ouverture

AL601F 2.0

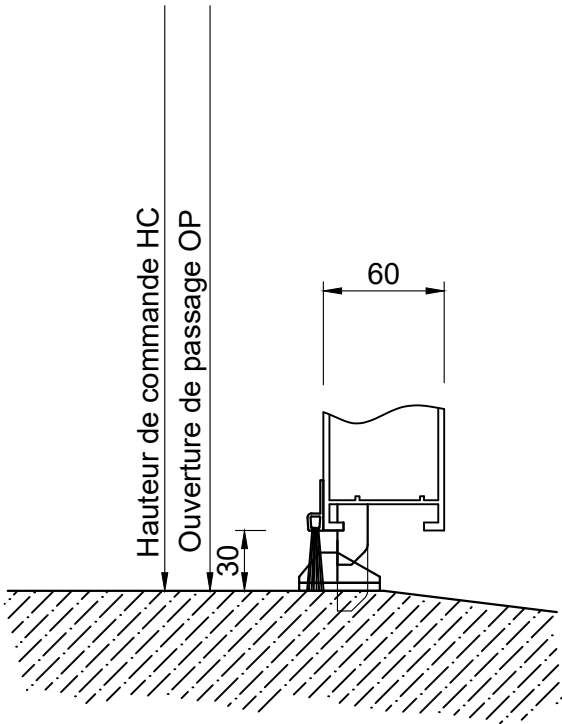

AL602F

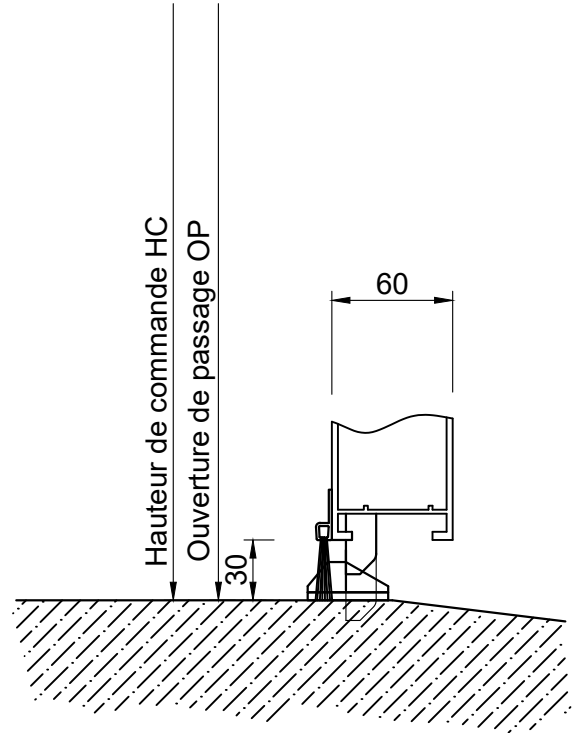

AL603F

pas possible

ST602F

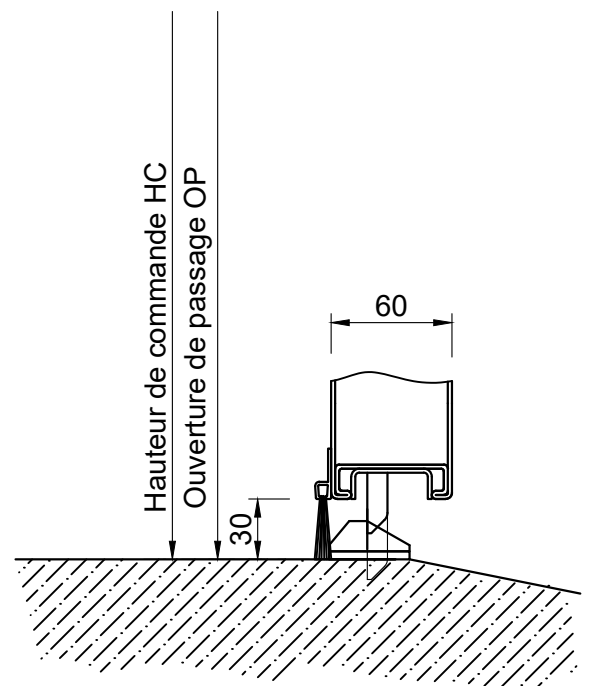

Finition au sol

Guidage au sol BF chauffage

Attention: 5% d'inclinaison dans le sens de l'ouverture

AL601F 2.0

pas possible

AL602F

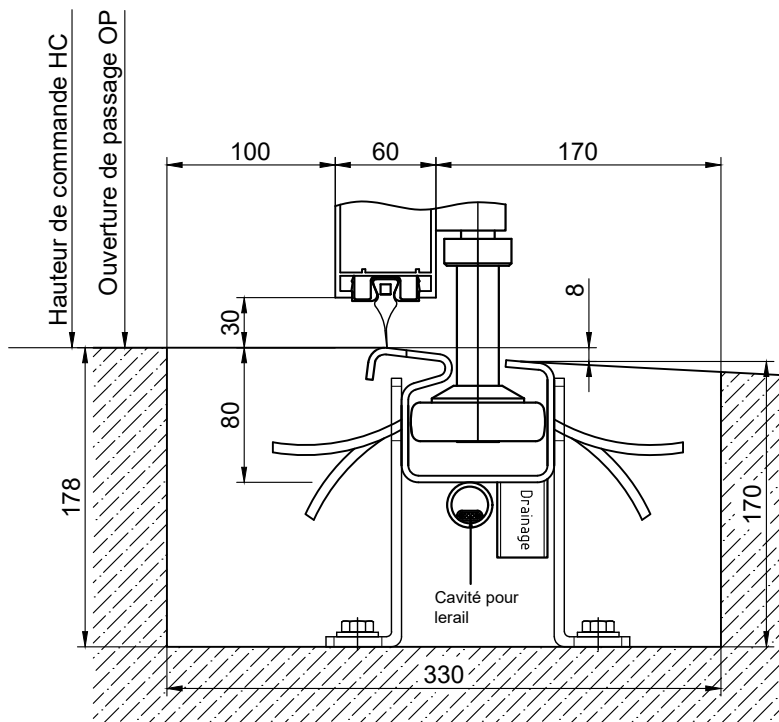

AL603F

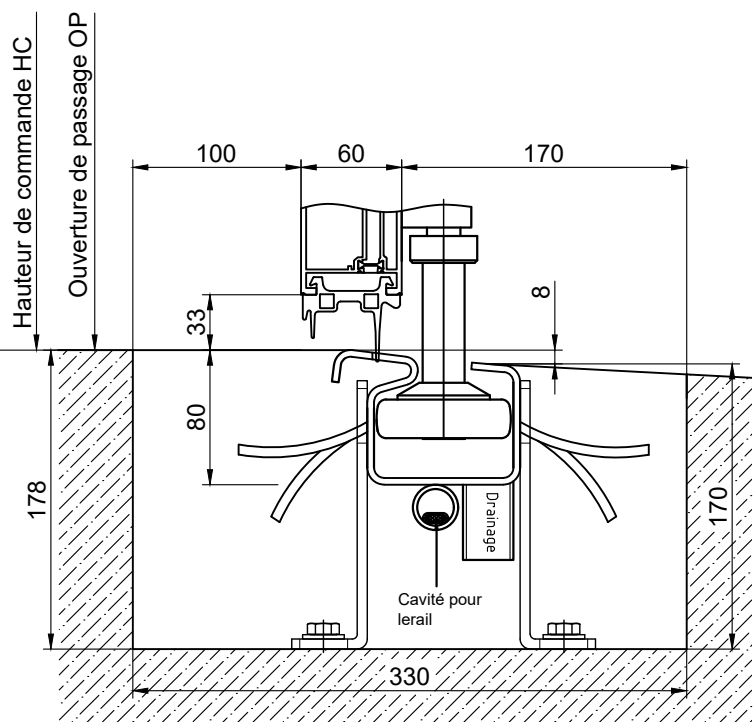

ST602F

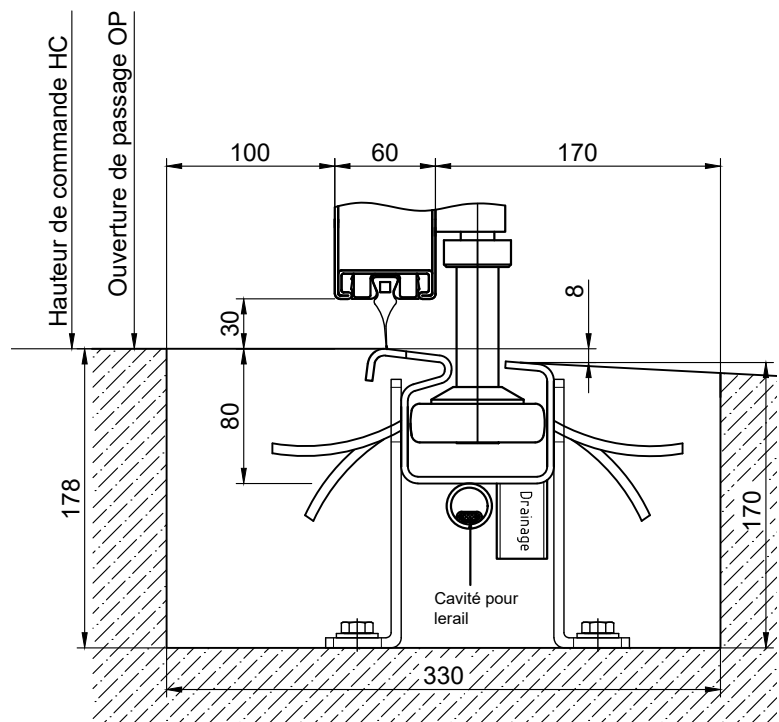

Finition au sol

Guidage au sol BF-light NIRO

Attention: 5% d'inclinaison dans le sens de l'ouverture

AL601F 2.0

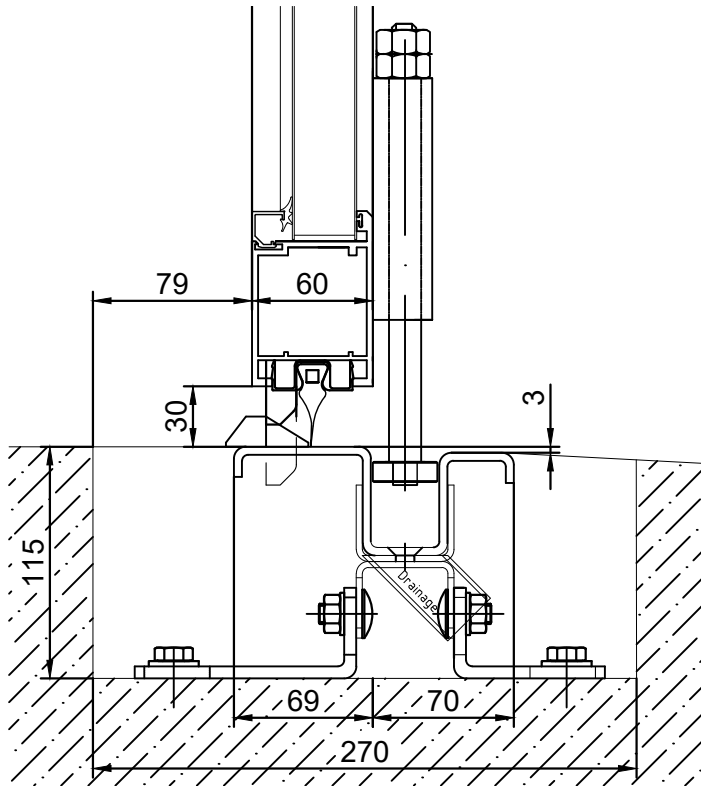

AL602F

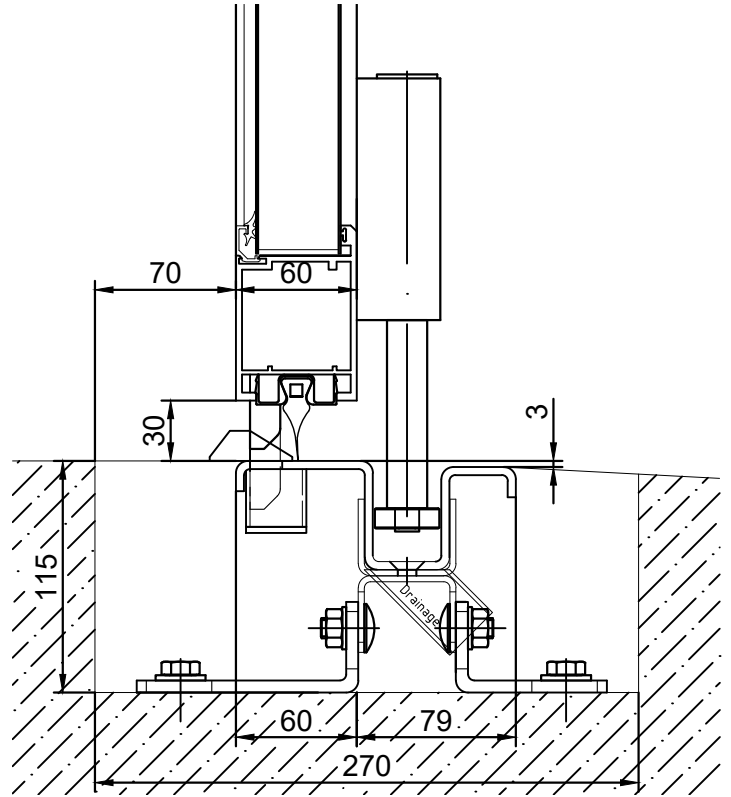

AL603F

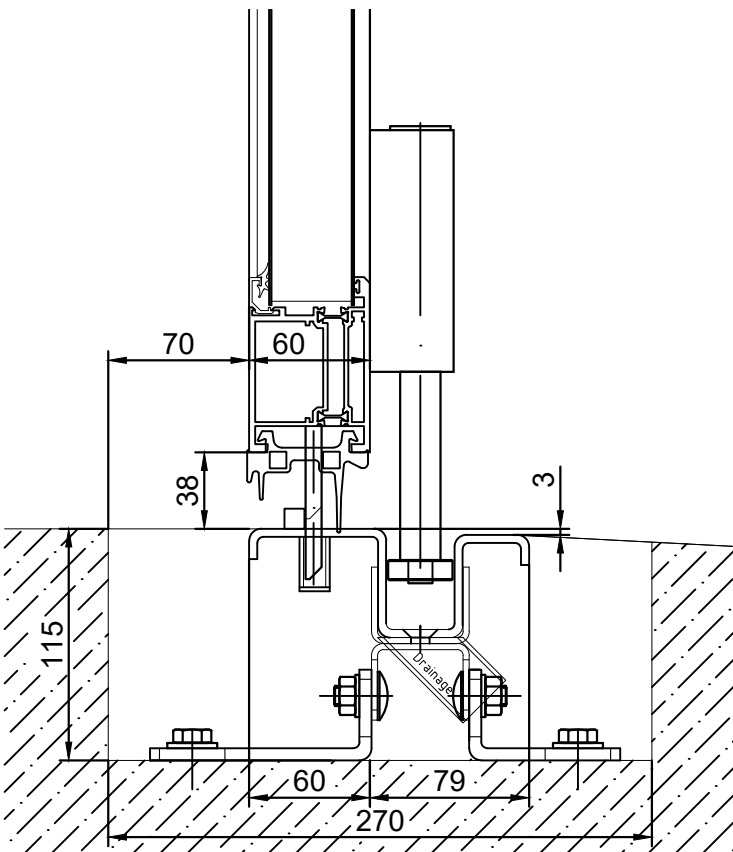

ST602F

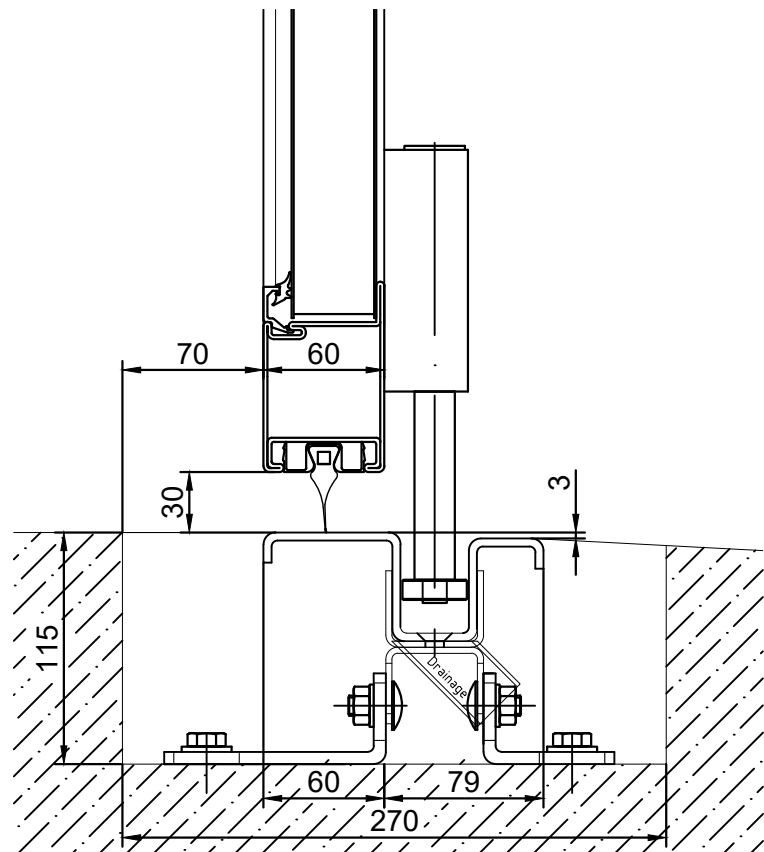

Finition au sol

Guidage au so BF-light NIRO chauffage

Attention: 5% d'inclinaison dans le sens de l'ouverture

AL601F 2.0

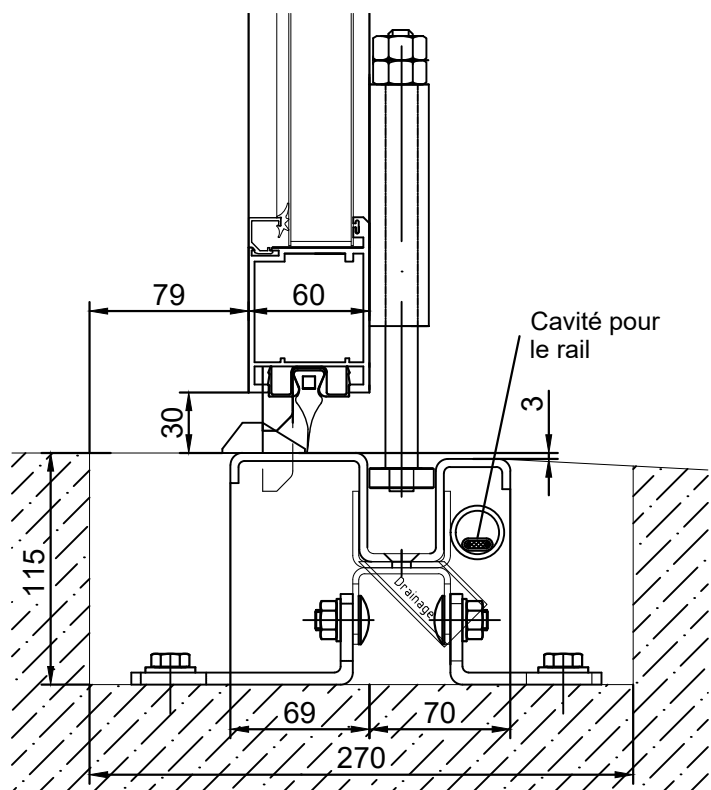

AL602F

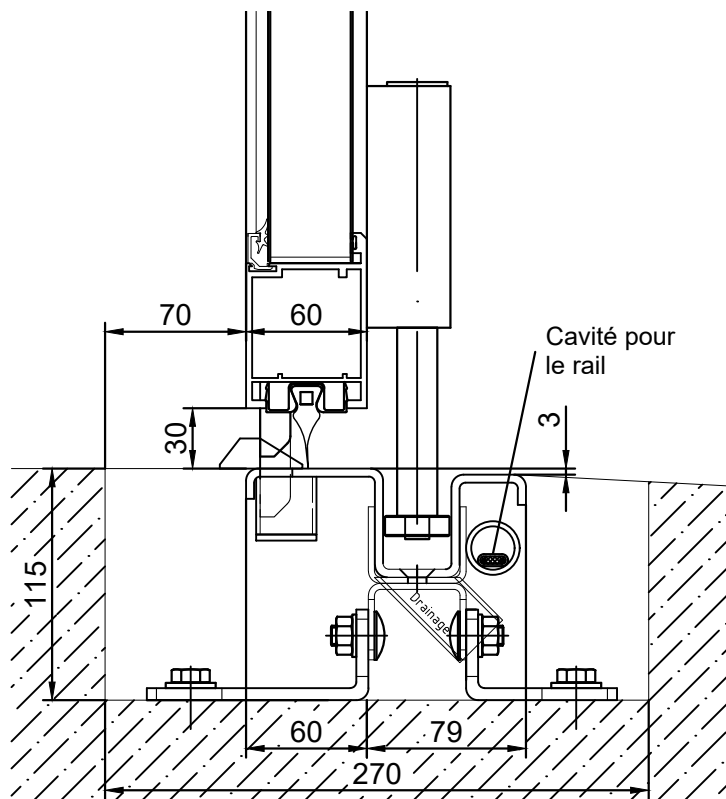

AL603F

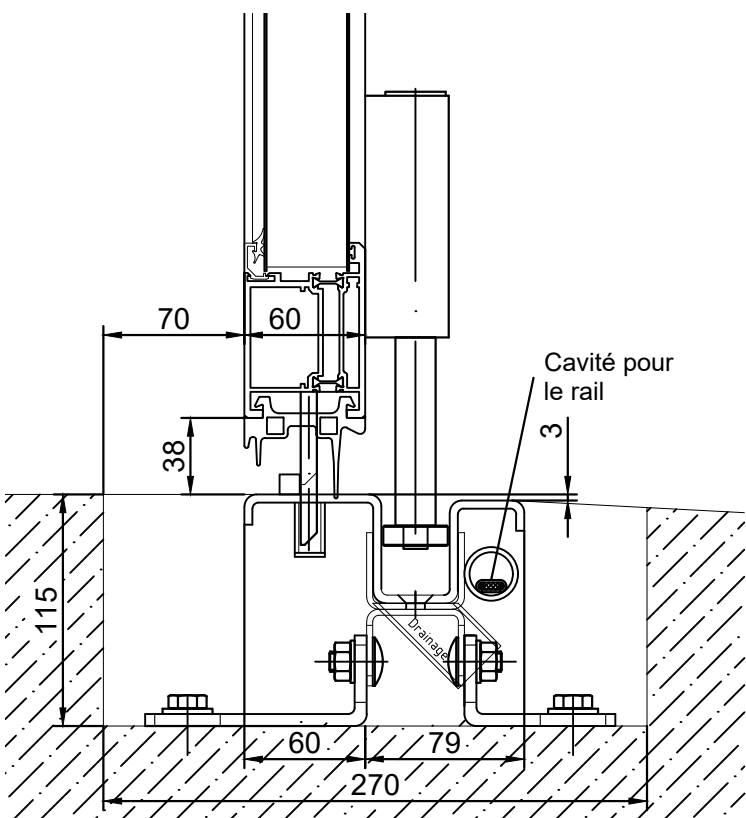

ST602F

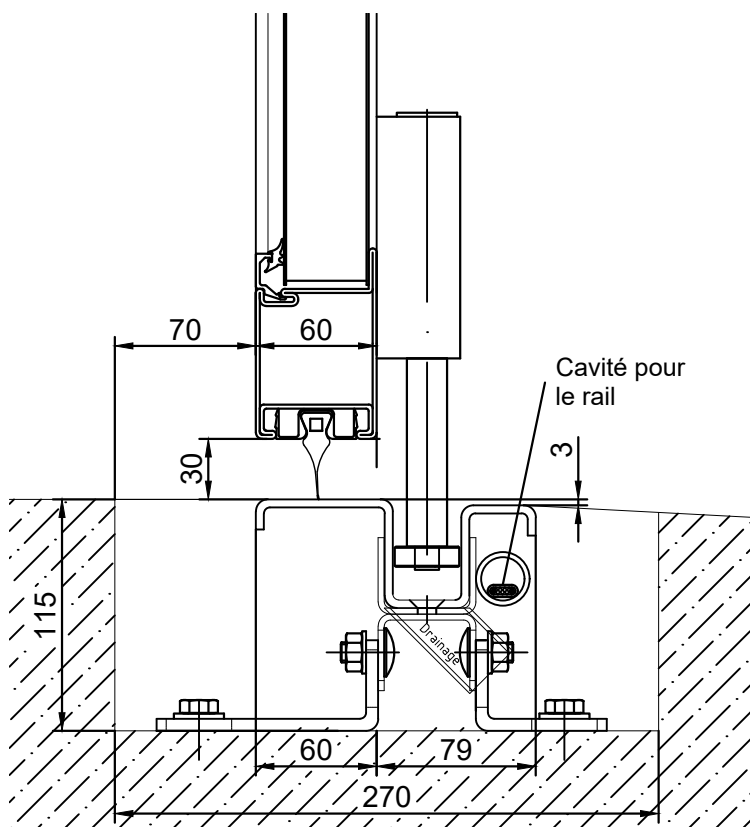

Coupe verticale et horizontale

AL601F 2.0

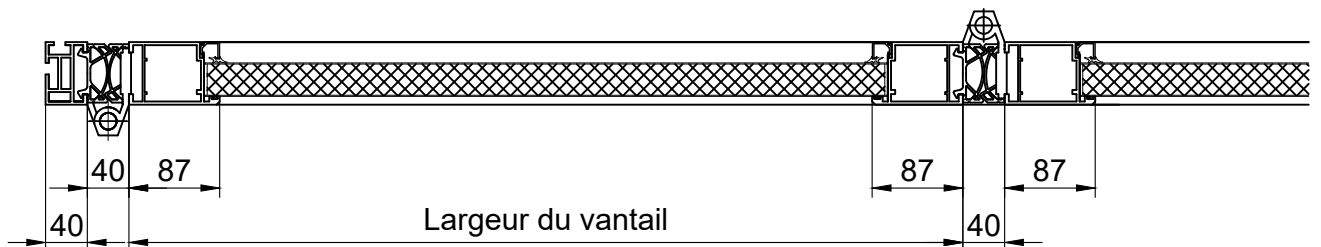
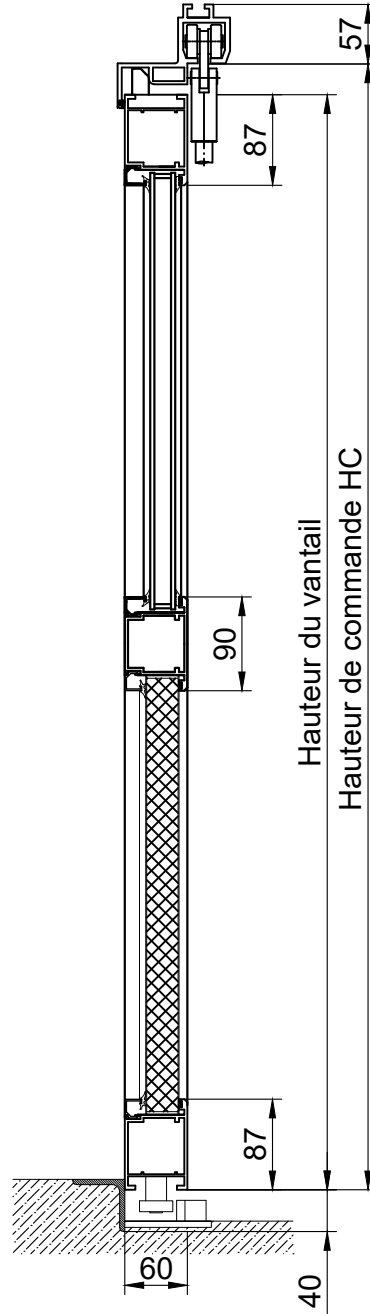

Coupe verticale et horizontale

AL603F

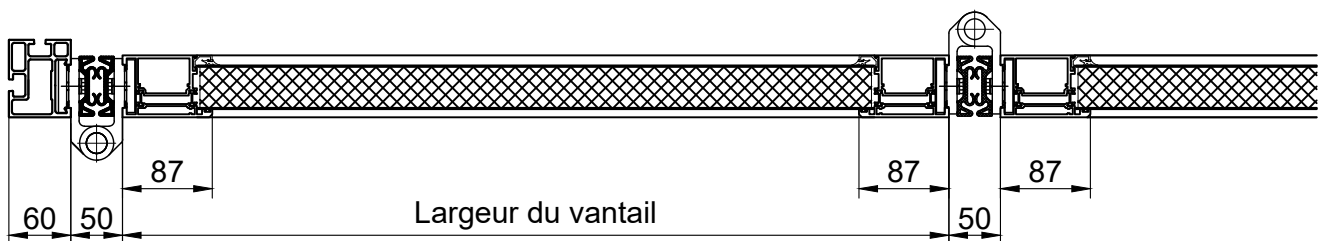
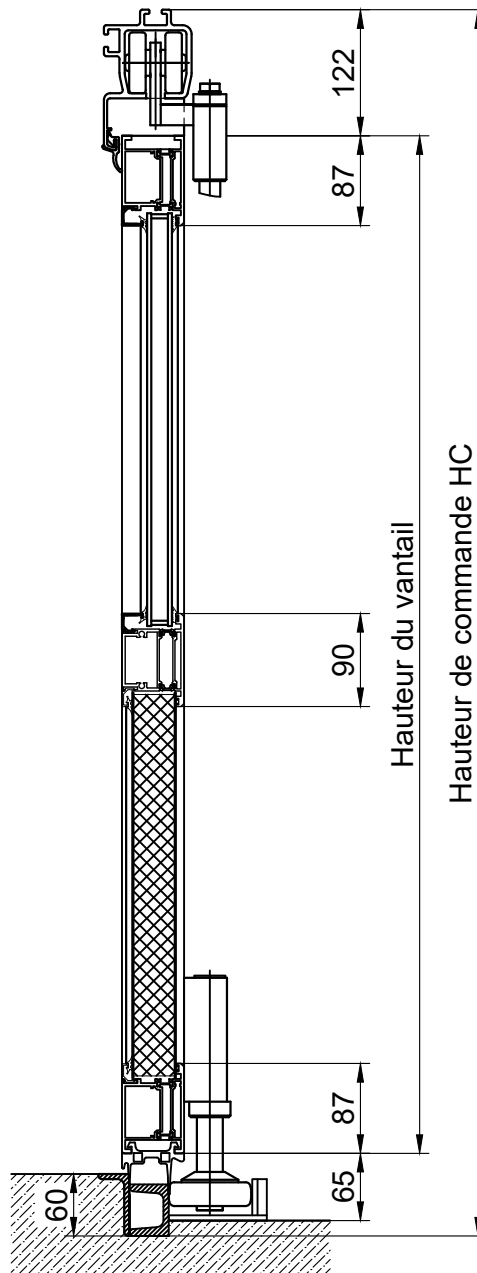

Coupe verticale et horizontale

ST602F

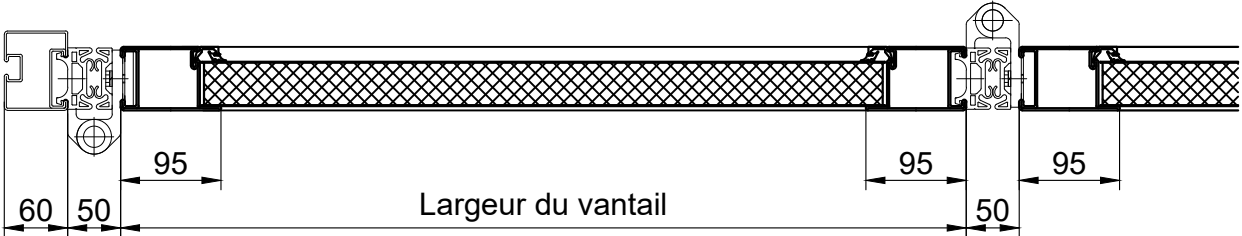
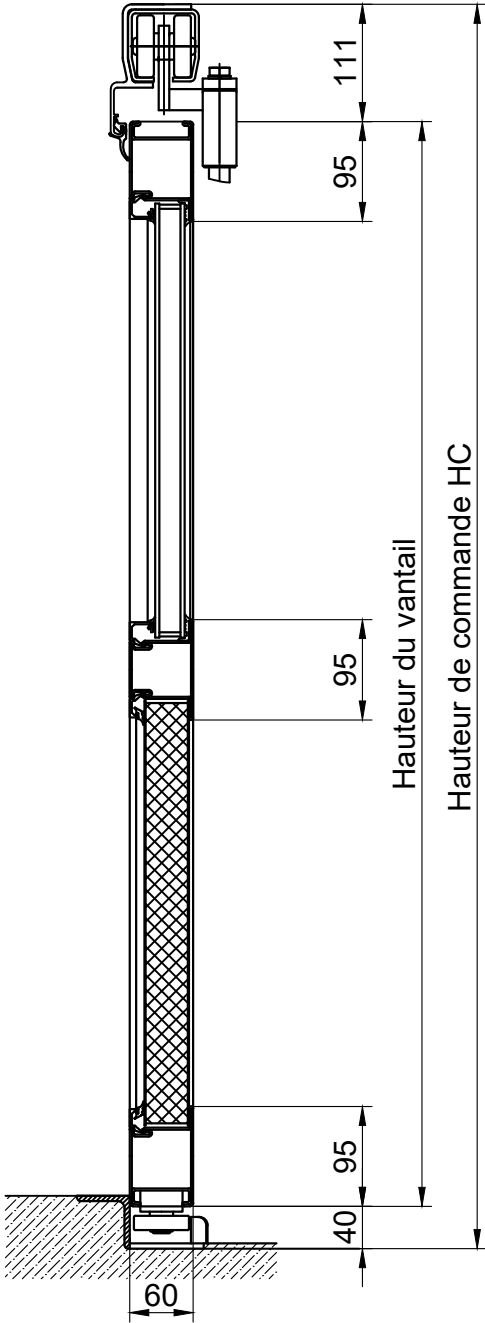

Barreau

AL601F 2.0

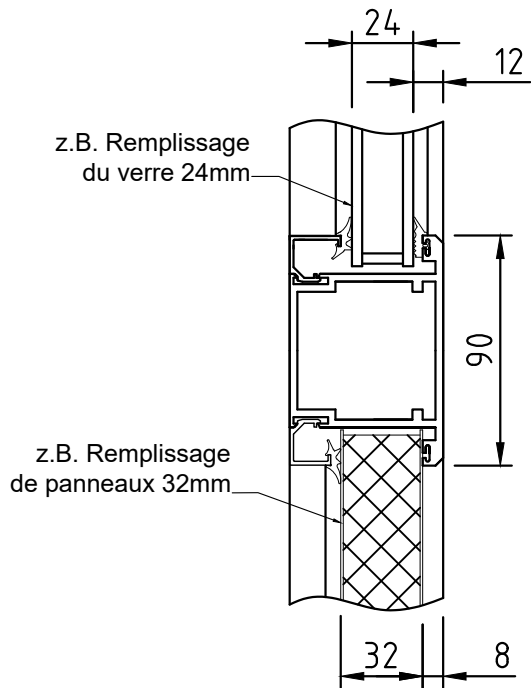

AL602F

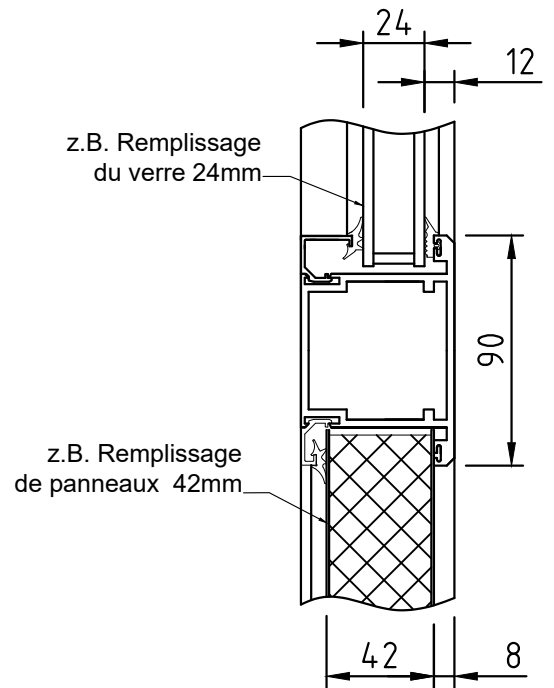

AL603F

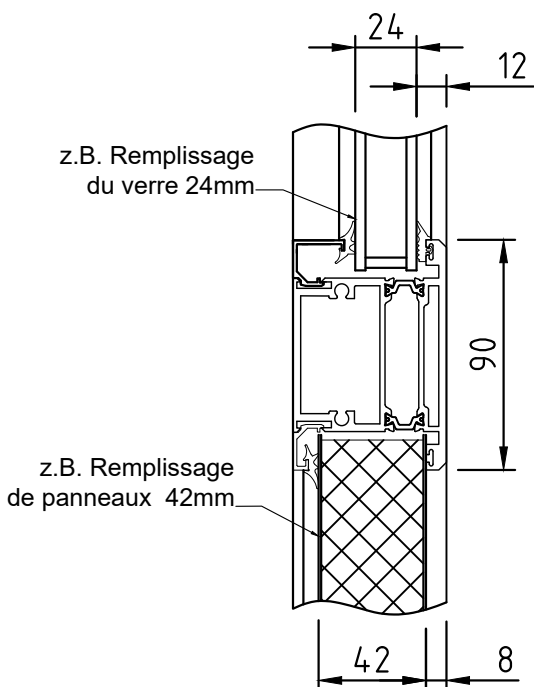

ST602F

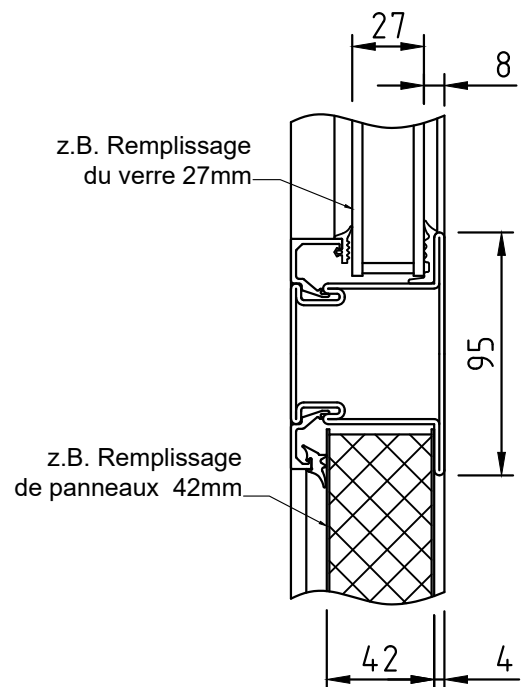

Élargissement du cadre

AL601F 2.0

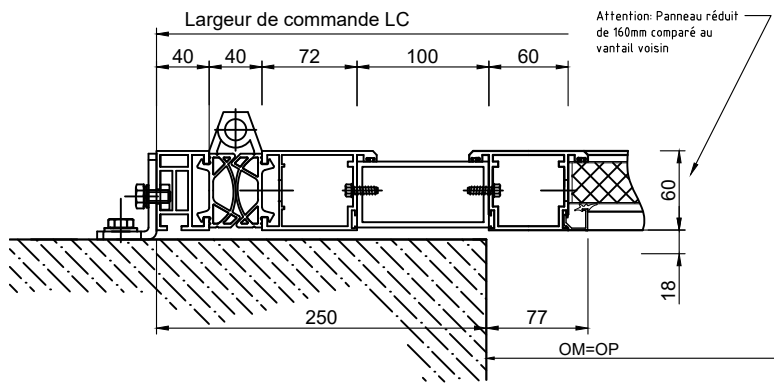

AL602F

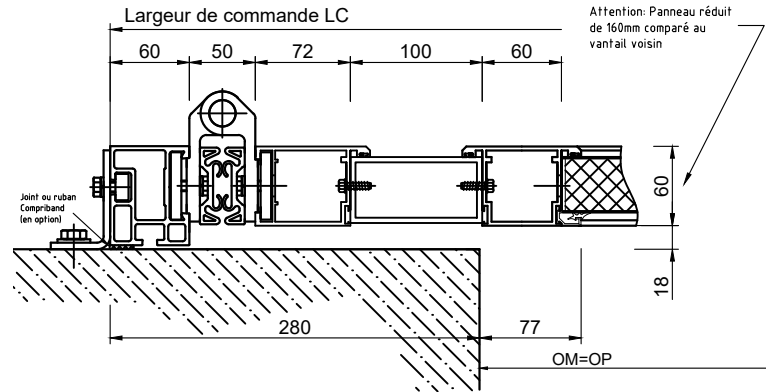

AL603F

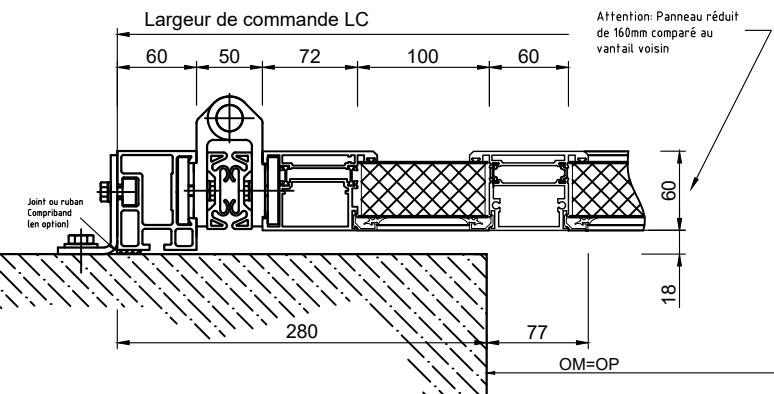

ST602F

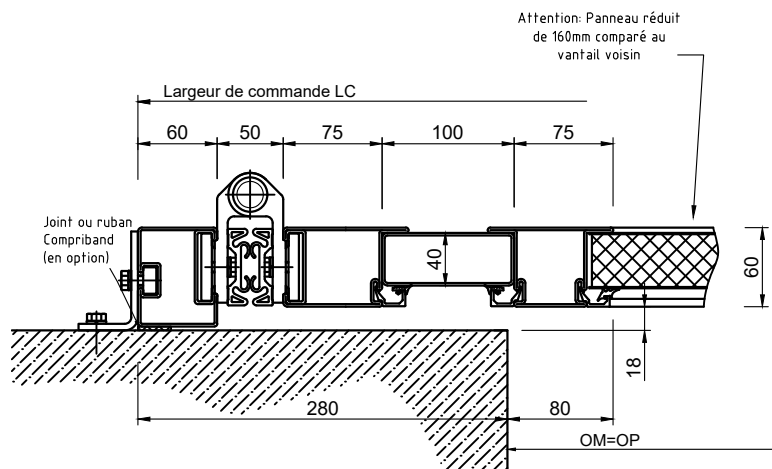

Vantail d'entrée

AL601F 2.0

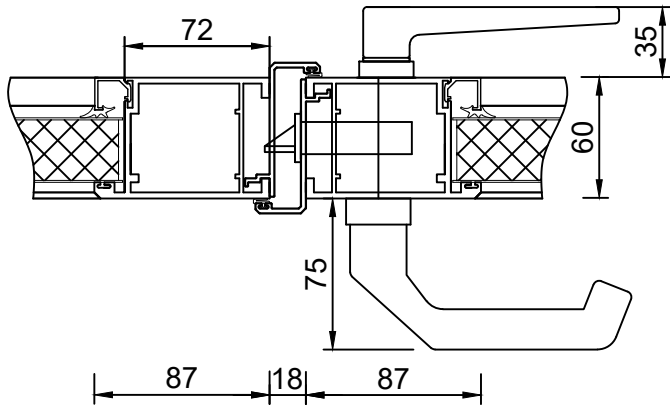

AL602F

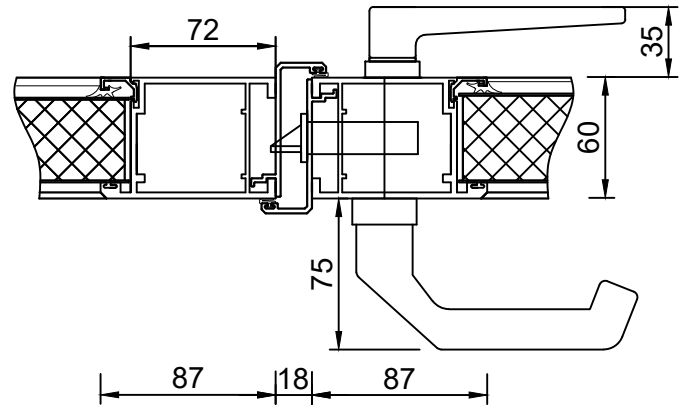

AL603F

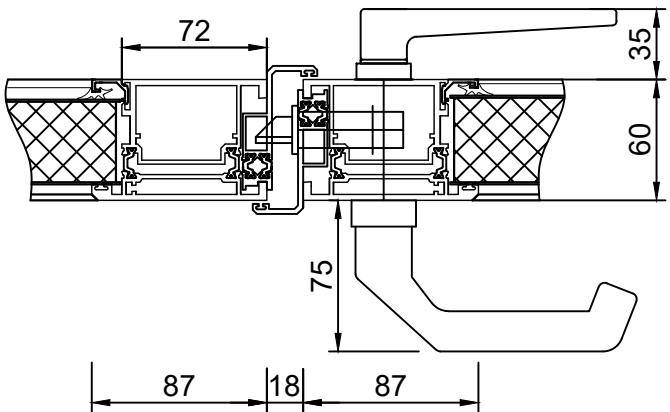

ST602F

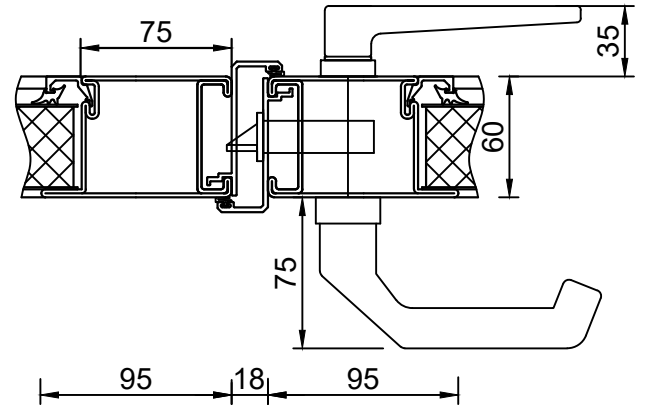

Porte d'entrée coupe horizontale

seulement possible d'ouvrir vers l'extérieur

AL601F 2.0

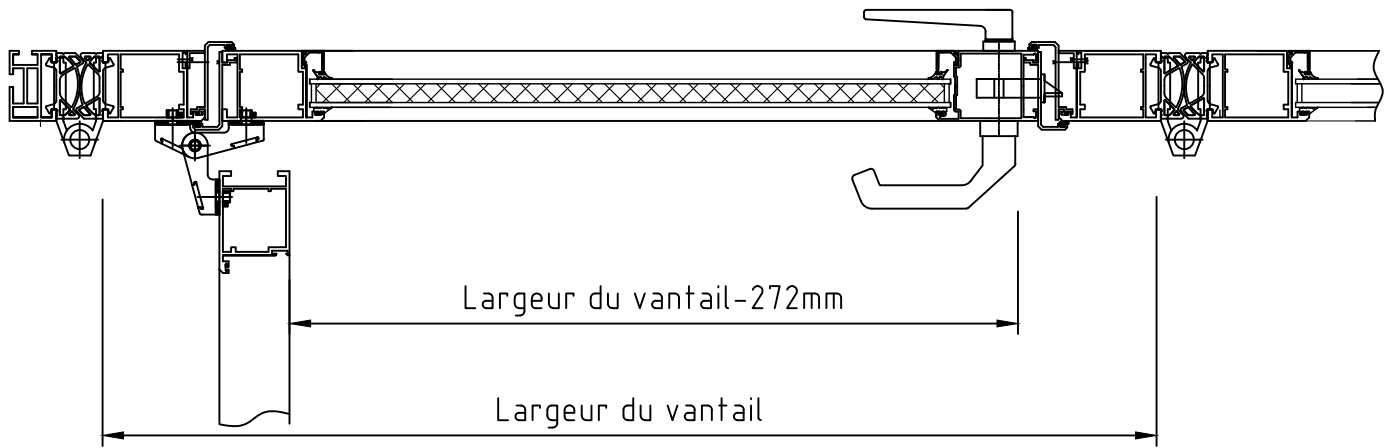

AL602F

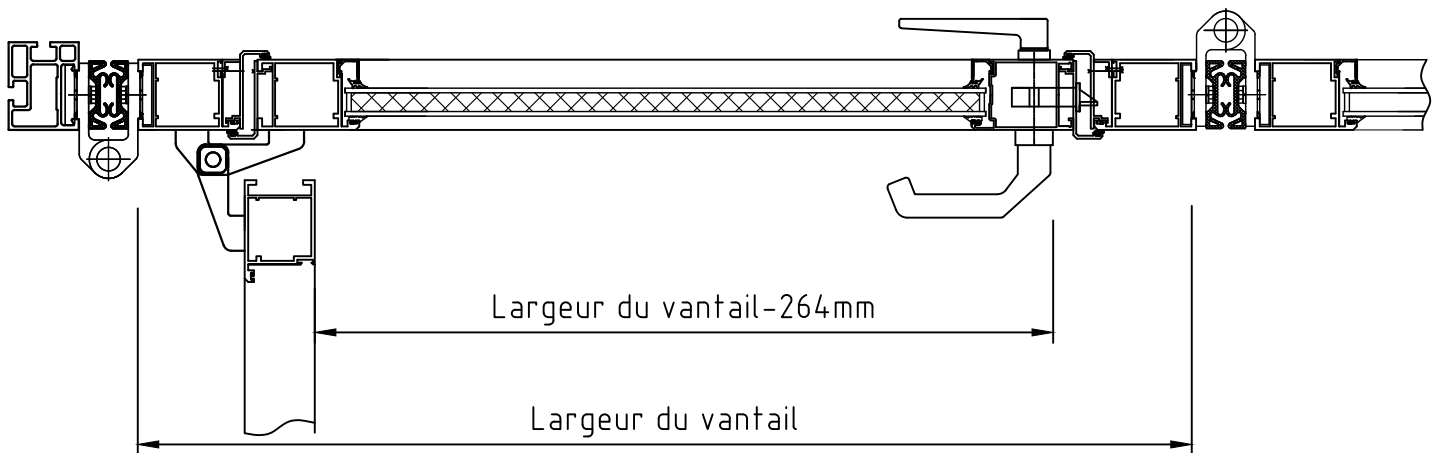

AL603F

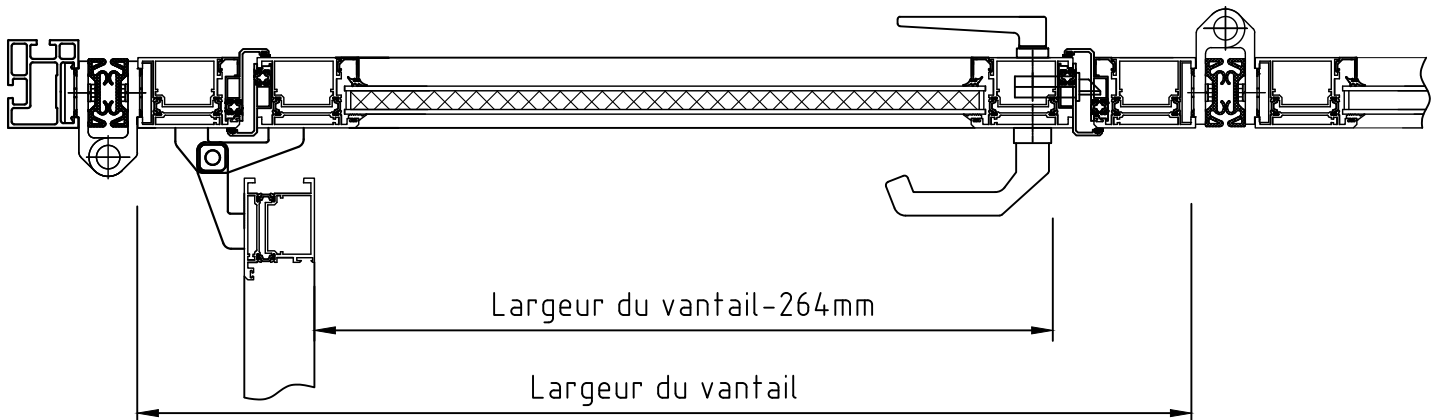

ST602F

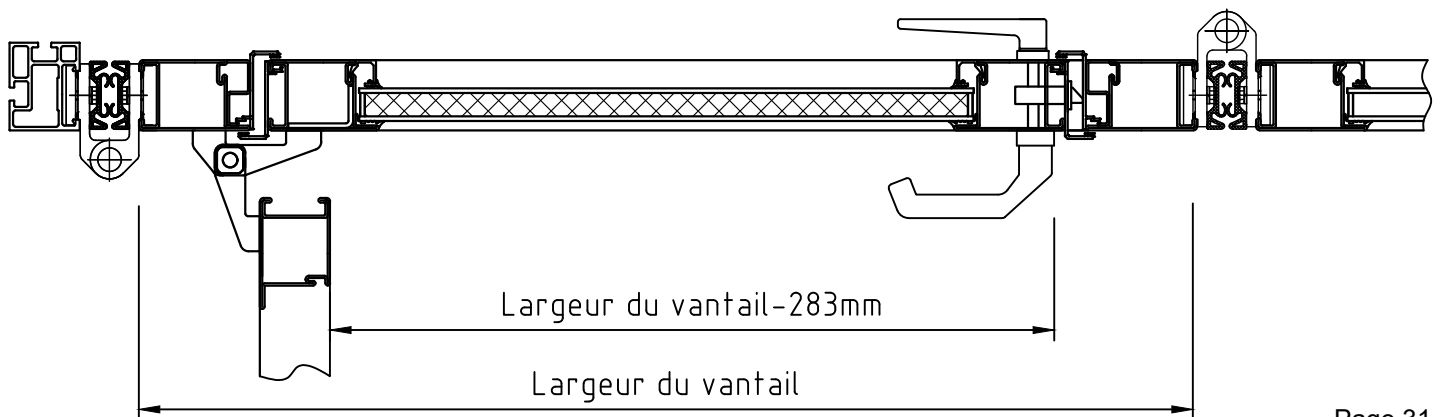

Porte d'entrée coupe verticale

seulement possible d'ouvrir vers l'extérieur

AL601F 2.0

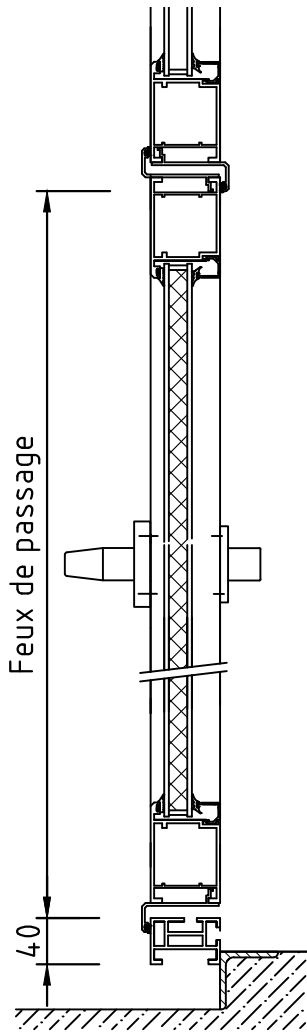

AL602F

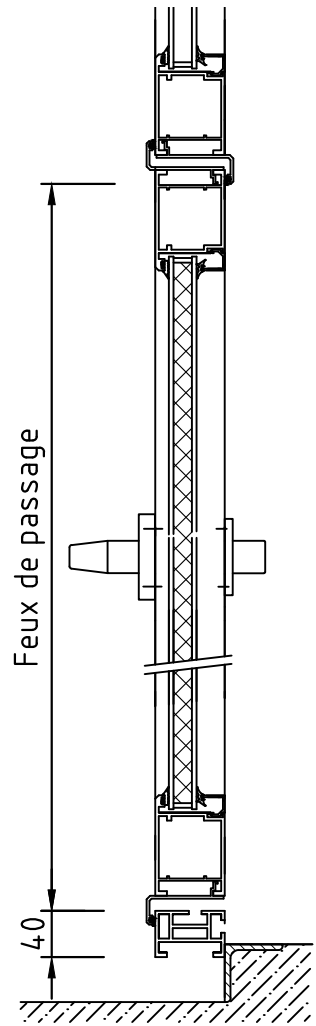

AL603F

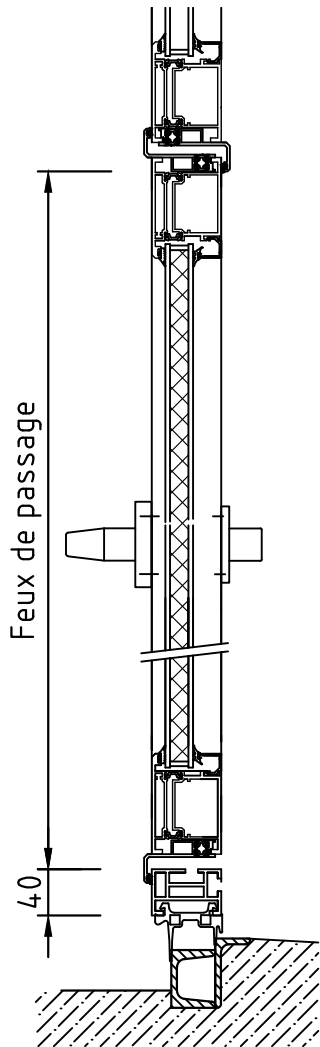

ST602F

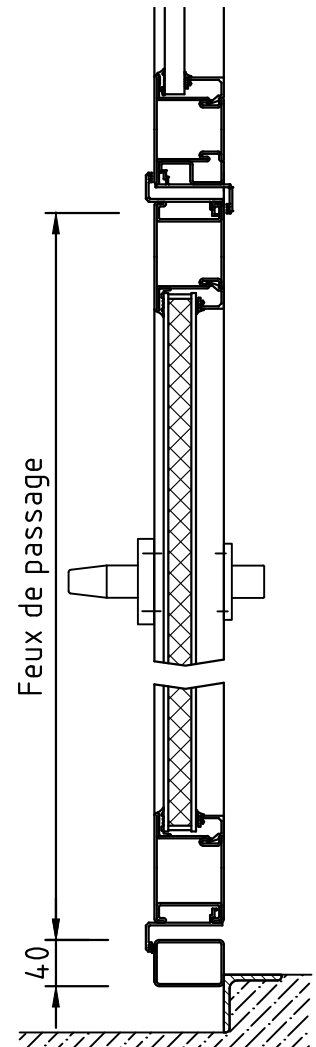

Porte d'entrée coupe verticale (Seuil plate en acier)

seulement possible d'ouvrir vers l'extérieur

AL601F 2.0

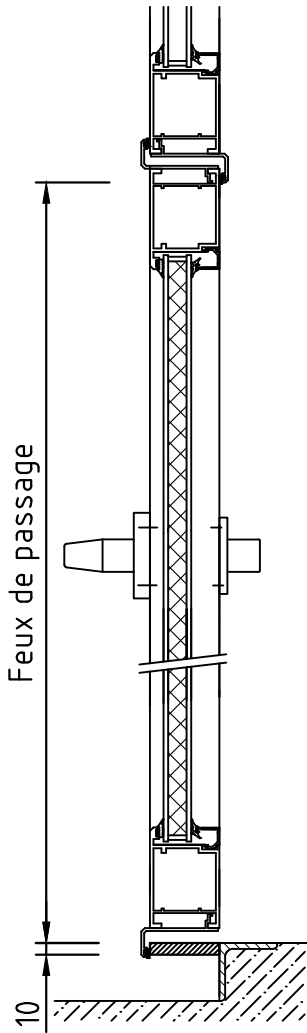

AL602F

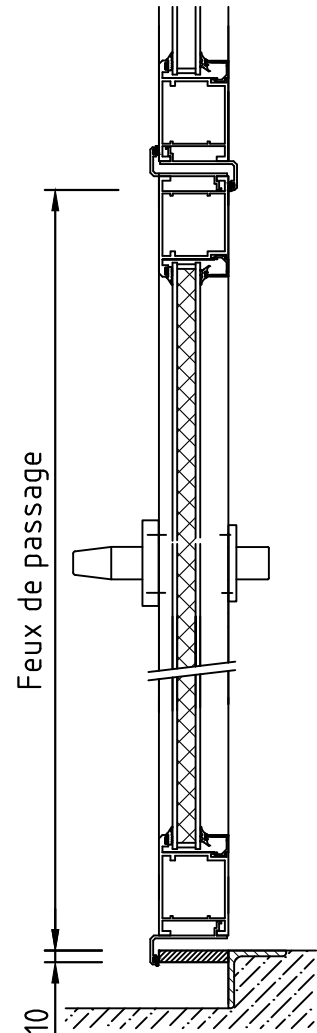

AL603F

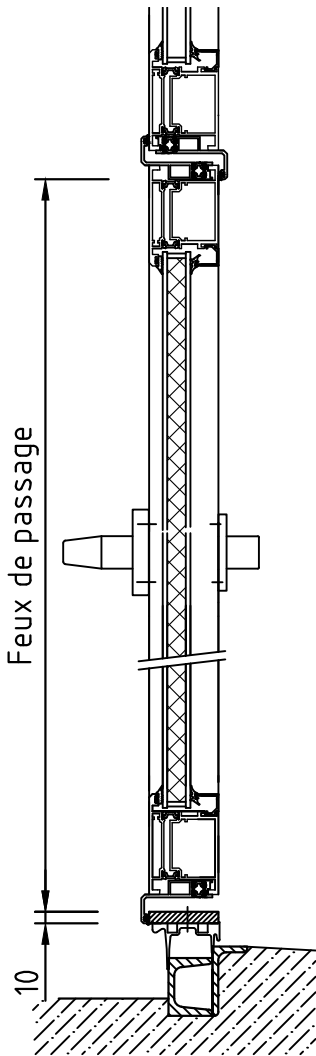

ST602F

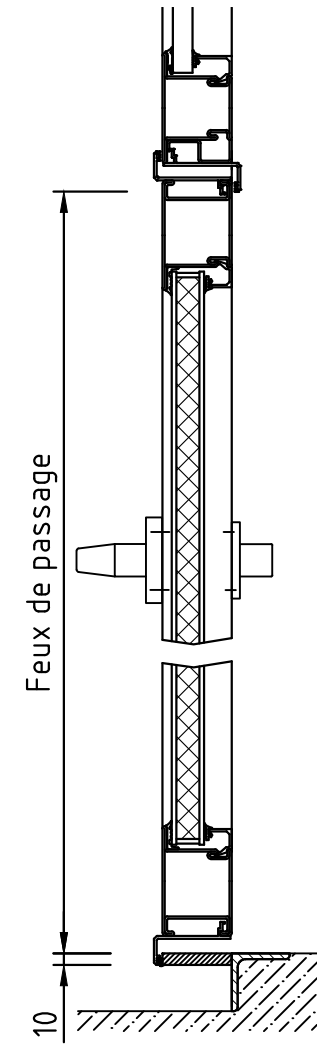

Porte d'entrée coupe verticale (Seuil en tube moulé)

Ouverture possible uniquement vers l'extérieur et uniquement avec un seuil bas avec une brosse d'étanchéité

AL601F 2.0

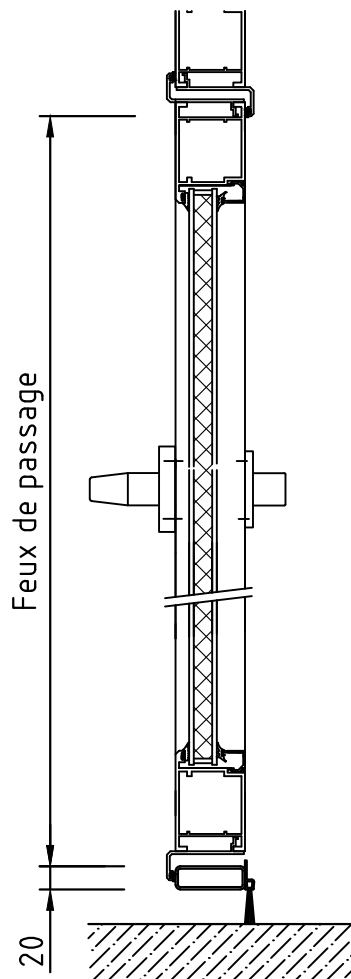

AL602F

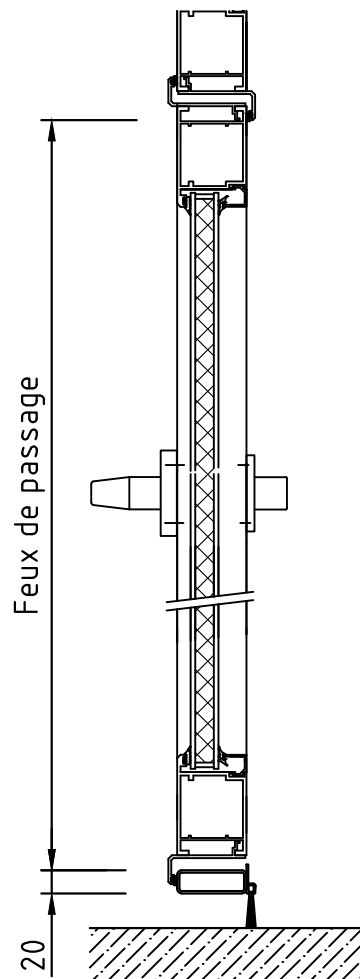

AL603F

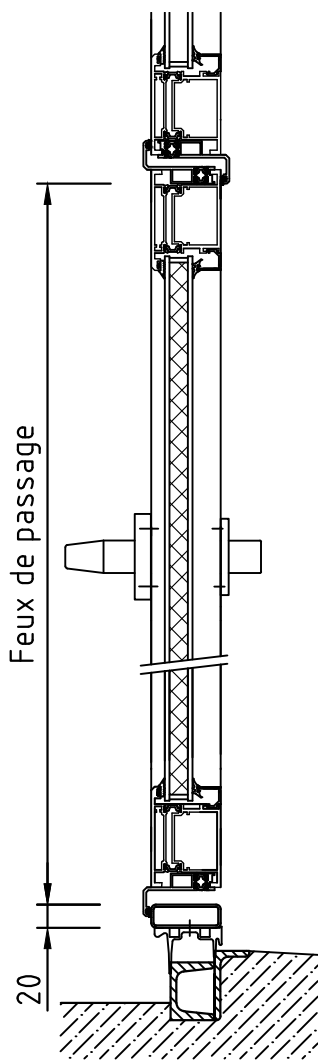

ST602F

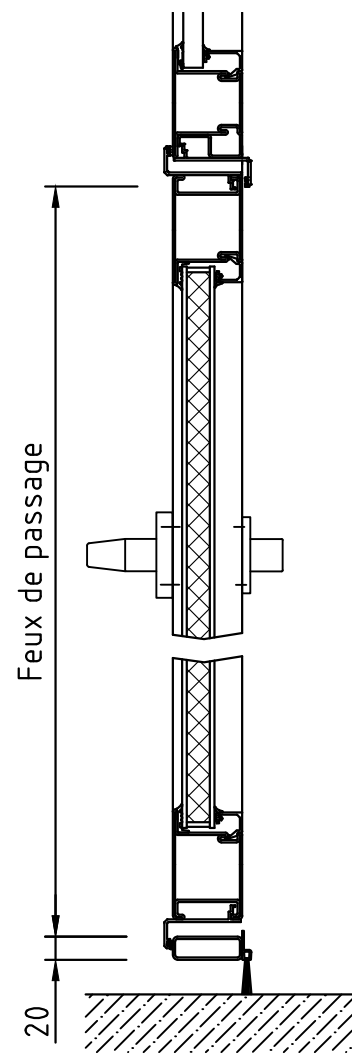

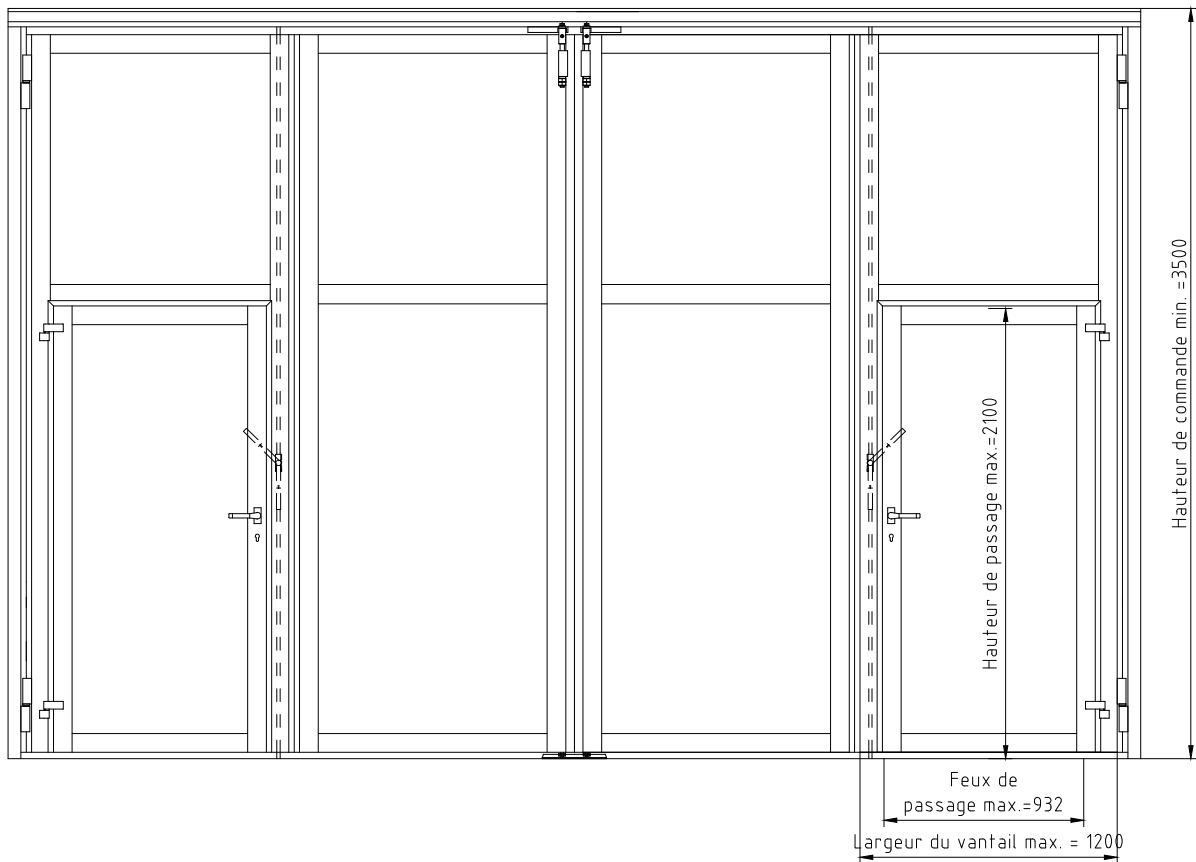

Coupe verticale

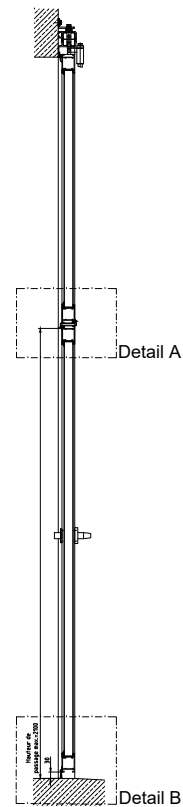

Detail A

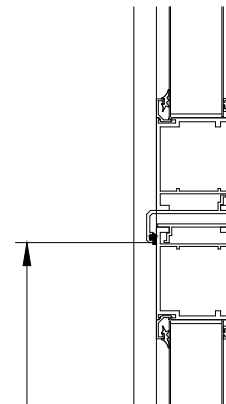

Detail B

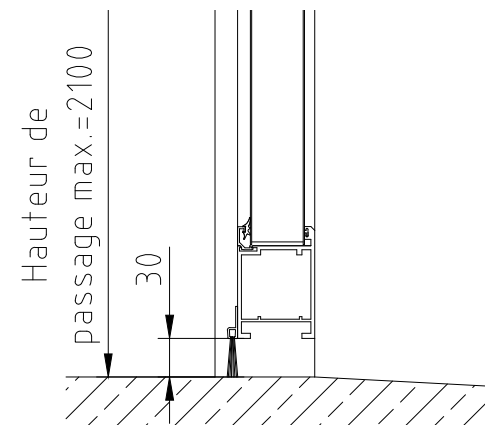

Coupe horizontale



Schéma du système sans porte d'entrée
seuil

Porte d'entrée coupe verticale (sans seuil)

Charnières possible uniquement côté sol, min.HC 4000mm

AL601F 2.0

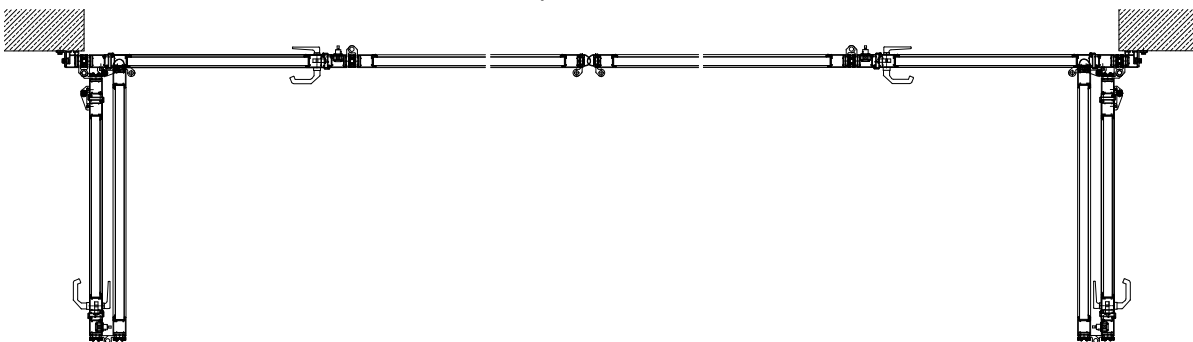
AL602F

pas possible

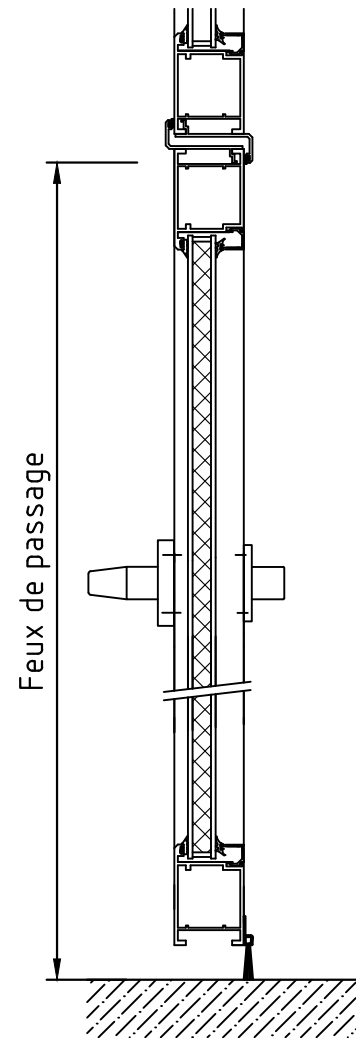

AL603F

ST602F

pas possible

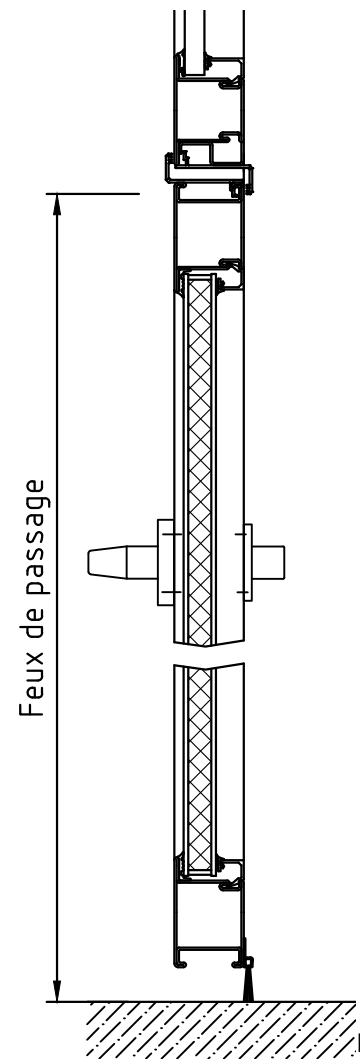

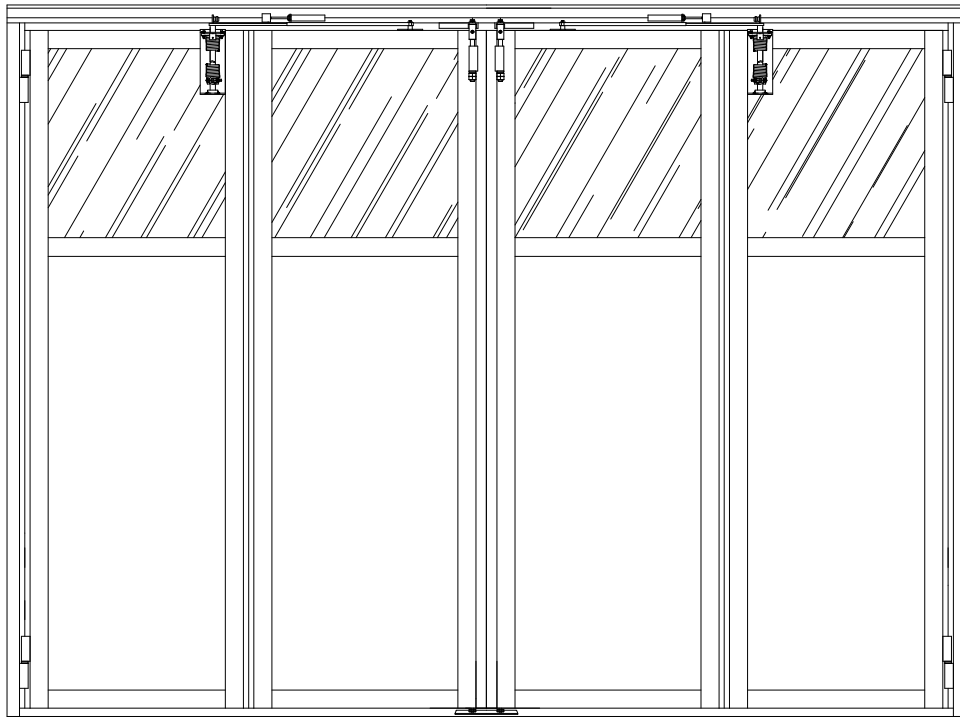

Coupe verticale

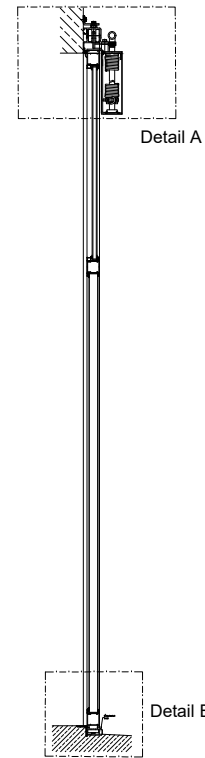

Detail A

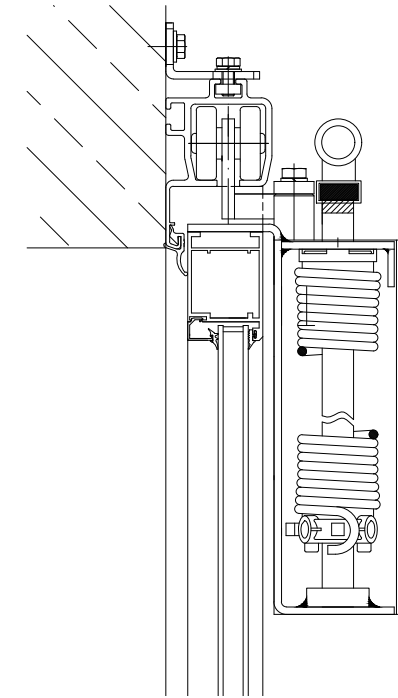

Coupe horizontale

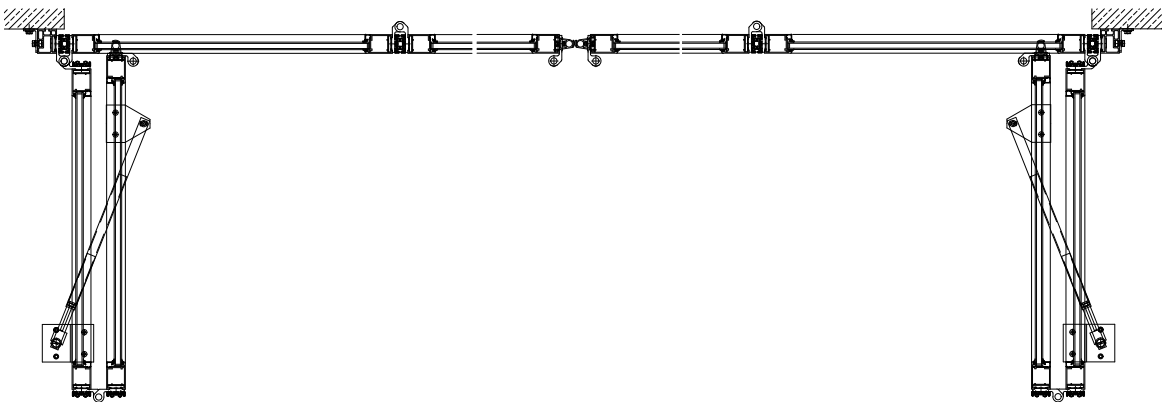

Detail B



Schéma du système ouverture automatique



Coupe verticale

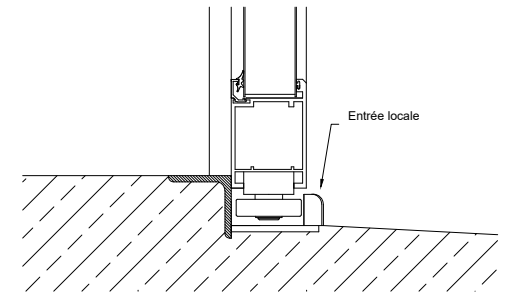
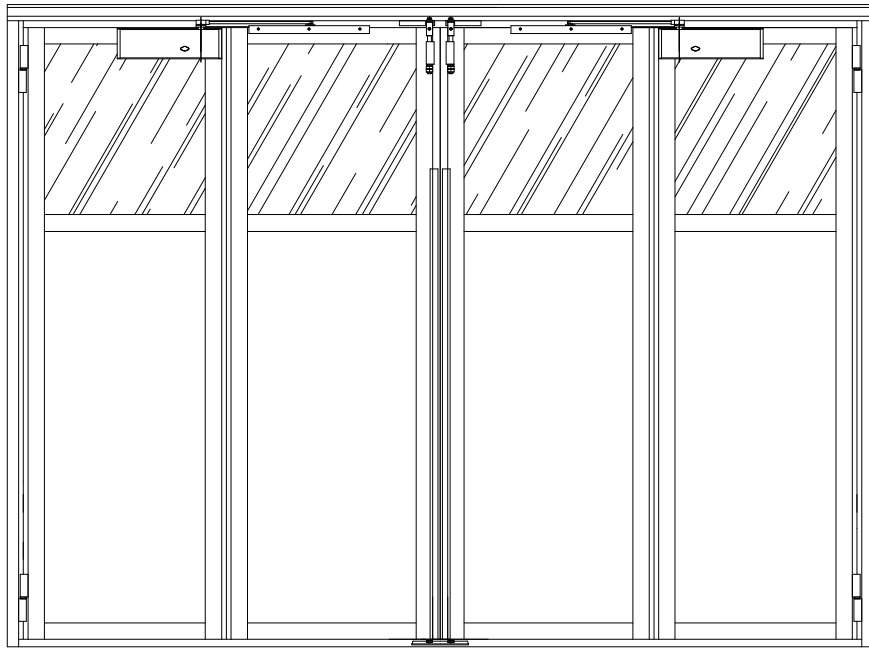
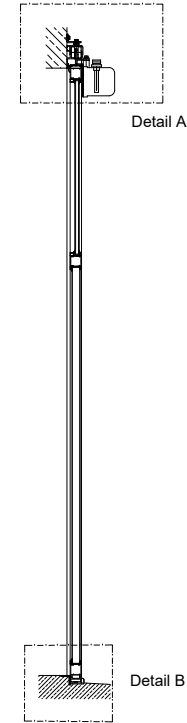

Detail A

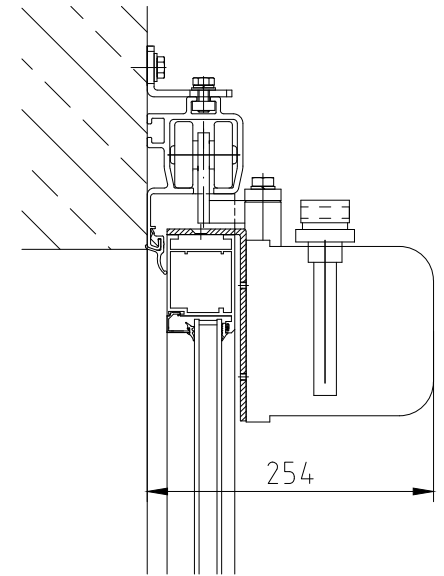

Coupe horizontale

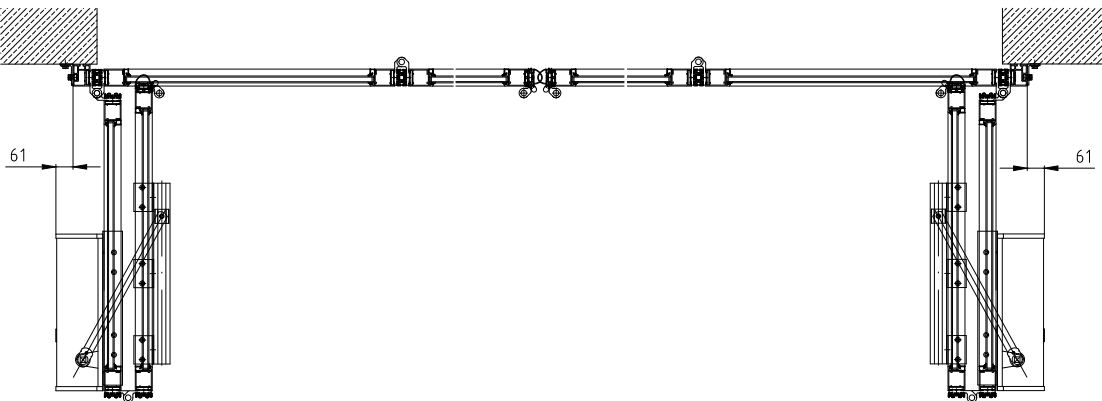

Detail B



Schéma du système entraînement BASIC de portes pliantes



Coupe verticale

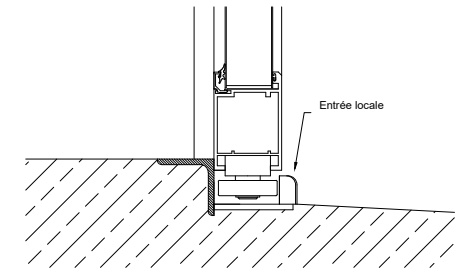
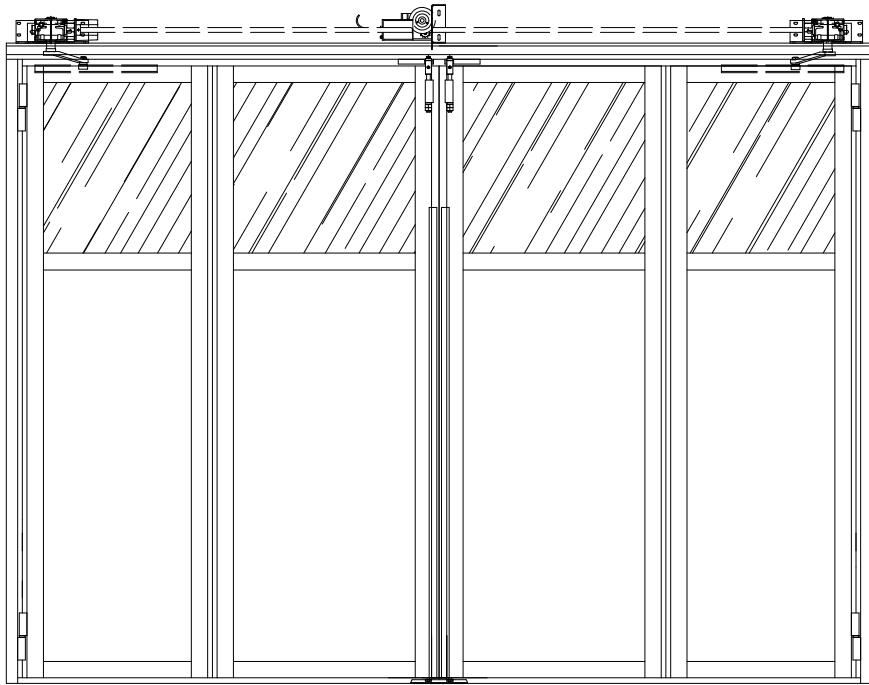
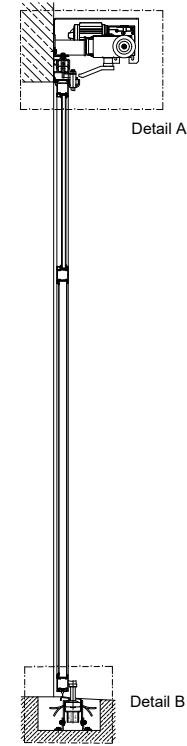

Detail A

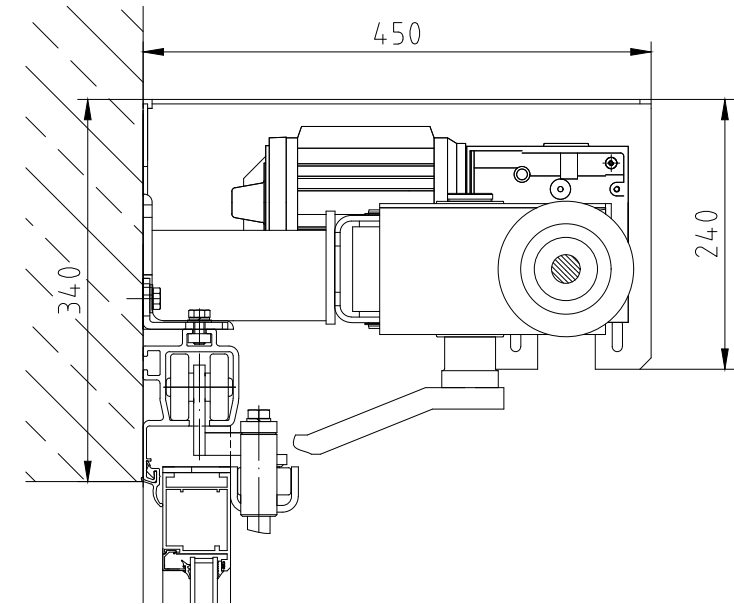

Coupe horizontale

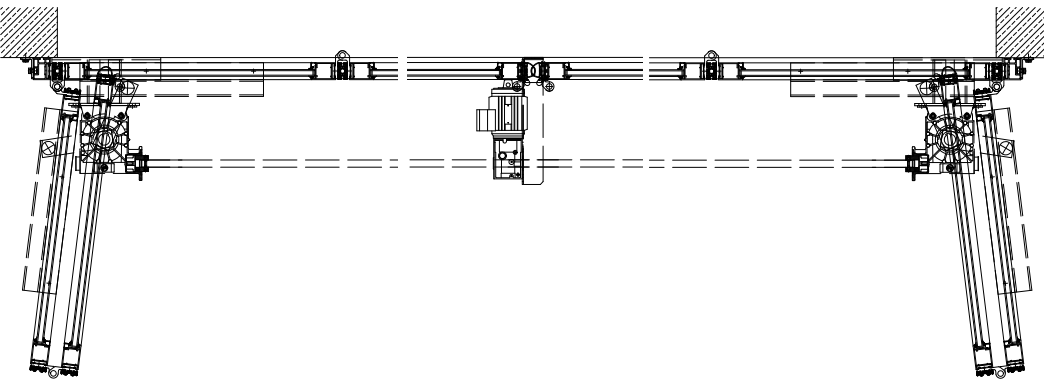

Detail B

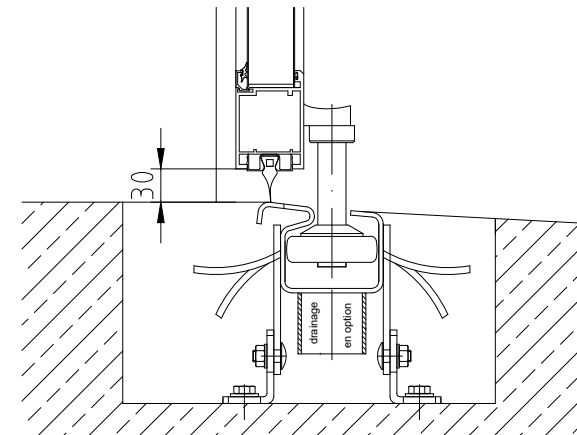

Schéma du système entraînement POWER de portes pliantes